

# CH3 Series

C&I Hybrid Inverter

CH3-(75K-125K)-(T6,T8)-EU

---

## User Manual



## Copyright Statement

This document, including all text, images, and designs contained herein, is the proprietary information of **Guangzhou Sanjing Electric Co., Ltd.** ("SAJ") and is protected by applicable copyright and trademark laws. No part of this publication may be reproduced, stored, distributed, or transmitted in any form or by any means without the prior written permission of **SAJ**.

The information in this document is provided "as is" for general guidance. While every effort has been made to ensure accuracy and completeness, **SAJ** reserves the right to modify the content herein without prior notice.

Guangzhou Sanjing Electric Co., Ltd. disclaims all implied warranties, including but not limited to warranties of merchantability and fitness for a particular purpose, and shall not be liable for any direct, indirect, incidental, or consequential damages arising out of or in connection with the use of this document or reliance on its content.

**SAJ (SAJ)** used in this document are the trademarks of Guangzhou Sanjing Electric Co., Ltd. All other brand names, trademarks, or registered trademarks mentioned herein are the property of their respective owners.

For the most current version of this document and product support, please scan the QR code or visit our website as shown below:

Website: <https://www.saj-electric.com/>



## Contact us

**Online technical support:** Go to <https://www.saj-electric.com/services-support-technical> to check FAQs or send your message or product enquiry.

**Call for assistance:** For SAJ support telephone numbers, see <https://www.saj-electric.com/locations> for your region support details.

- **Headquarter:** Guangzhou Sanjing Electric Co., Ltd.
- **Address:** SAJ Innovation Park, No.9, Lizhishan Road, Guangzhou Science City, Guangdong, P.R.China.
- **Tel:** +86 20 6660 8588
- **E-mail:** [service@saj-electric.com](mailto:service@saj-electric.com)
- **Website:** <https://www.saj-electric.com/>

## **Warranty**

Check the product warranty conditions and terms on the SAJ website: <https://www.saj-electric.com/>.

## About this document

This user manual provides product introductions and instructions of operating, maintaining, and troubleshooting the SAJ product.

You can find the latest version of this document as eManual at <https://www.saj-electric.com/>.

**Note:**

Illustrations in this document show only essential details and may differ from the actual product.

**Validity**

This manual is valid for the following product:

- CH3 Series

**Target Audience**

This document is applicable to the personnel that transport, install, and operate on the product. The personnel are required to have the following qualifications:

- A certain level of expertise in electronics, electrical wiring, and mechanical knowledge in electrical and mechanical schematics.
- Being familiar with the composition and working principles of the product and its upstream and downstream equipment.
- Professional training related to the installation and commissioning of electrical equipment.
- The ability to respond urgently to dangers or emergencies that may arise during installation or commissioning.
- Being familiar with relevant standards and regulations in the country or region where the project is located.
- Being familiar with the contents in this manual.

**Use of the Manual**

Read the user manual carefully before any installation, operation and maintenance and follow the instructions during installation and operation. Always keep the printed manual available for future reference.

**Levels of Warning Messages** **DANGER**

Indicates a hazardous situation which, if not avoided, will result in death or serious injury.

 **WARNING**

Indicates a hazardous situation which, if not avoided, will result in serious injury or moderate injury.

 **CAUTION**

Indicates a hazardous situation which, if not avoided, will result in minor or moderate injury.

 **NOTICE**

Indicates a situation which, if not avoided, can result in property damage.

## Revision history

Version	Date	Changes
V0.0	2026-04-21	First version.

# Contents

<b>1. Safety instructions.....</b>	<b>3</b>
1.1. Inverter safety instructions.....	3
1.2. Safety symbols.....	5
<b>2. Product information.....</b>	<b>6</b>
2.1. Product introduction.....	6
2.1.1. Model description.....	6
2.1.2. Dimensions.....	7
2.1.3. Electrical terminals.....	7
2.1.4. Communication terminals.....	9
2.2. Grid integration types.....	12
2.3. Work mode.....	13
<b>3. Transportation and storage.....</b>	<b>15</b>
3.1. Transportation equipment.....	15
<b>4. Installation instructions.....</b>	<b>17</b>
4.1. Installation Preparation.....	17
4.1.1. Precautions.....	17
4.1.2. Installation environment requirement.....	17
4.1.3. Plan the installation site.....	17
4.1.4. Lifting equipment.....	19
4.1.5. Installation tools.....	21
4.1.6. Packing list.....	22
4.2. Mount the inverter.....	22
4.2.1. Mount the inverter on wall.....	23
4.2.2. Mount the inverter on external frame.....	27
<b>5. Electrical connection.....</b>	<b>31</b>
5.1. Electrical connection safety.....	31
5.1.1. Wiring guidelines.....	31
5.1.2. Ground protection.....	31
5.1.3. AC- and DC-side handling.....	32
5.1.4. Electrostatic Discharge (ESD) Protection.....	32
5.1.5. Earth fault alarm monitoring.....	32
5.2. Plan the cable connections.....	32
5.2.1. Single deployment.....	32
5.2.2. Parallel deployment.....	33
5.2.3. Smart meter connection solutions.....	35
5.3. Prepare electrical cables.....	38
5.4. Connect the grounding cable.....	42
5.5. Connect the AC power cables.....	42
5.6. Connect the smart meters.....	46
5.7. Connect the communication cables.....	47
5.7.1. Connect the emergency shutdown device.....	50
5.7.2. <b>Connect the RCR device</b> .....	50
5.7.3. Connect the DRED device (Australia and New Zealand).....	51
5.7.4. Connect the generator communication.....	51

---

5.7.5. Connect the parallel deployment communication.....	51
5.7.6. Turn on DIP switches.....	51
5.8. Connect the battery cables.....	52
5.9. Connect the PV cables.....	52
<b>6. Startup and Shutdown.....</b>	<b>57</b>
6.1. Start up the inverter.....	57
6.2. Shut down the inverter.....	57
<b>7. Commissioning on App.....</b>	<b>59</b>
7.1. About elekeeper.....	59
7.2. Download the elekeeper App.....	59
7.3. Log in to the elekeeper App.....	59
7.4. Perform initialization settings.....	60
7.5. Perform installation diagnosis.....	63
7.6. View or change the inverter settings.....	64
7.7. View or configure the V-Watt and Volt-Var modes.....	66
7.8. Configure the AFCI function.....	67
7.9. Run self-test for grid connection (For Italy).....	68
<b>8. Operation and maintenance.....</b>	<b>70</b>
8.1. General safety instructions.....	70
8.2. Regular maintenance.....	70
<b>9. Troubleshooting.....</b>	<b>72</b>
<b>10. Product specification.....</b>	<b>81</b>
10.1. CH3-(75K-125K)-(T6,T8)-EU.....	82
10.2. CH3-(75K-125K)-(T6,T8)-G-EU.....	85

# 1. Safety instructions

## 1.1. Inverter safety instructions

### Personal Safety



#### DANGER

##### Risk of personnel hazard or equipment damage due to improper operations

Improper operations performed on energized equipment by unqualified personnel may lead to equipment failure or safety hazards.

- Only qualified and trained professionals who are familiar with electrical installation and local codes may install, maintain, or repair the equipment.
- Before any operation, read the safety precautions thoroughly and always follow the standard procedures during operation. Non-standard and improper operations on the energized equipment may cause fire, electric shocks, or explosion.
- Do not reconstruct or alter the equipment, add components, or change the installation sequence without permission. Any unauthorized operation including modification of product functionality of any form may cause lethal hazard to the operator, third parties, the units or their property.
- Before any operation, remove conductive objects such as watches, bracelets, bangles, rings, and necklaces to prevent electric shocks.
- During operation, do not open the housing or touch electrical terminals.



#### WARNING

##### Risk of personal injury due to direct contact with the components or housing

Direct contact with hazardous moving or hot components during the inverter's operation may lead to personal injury.

- Do not touch a running fan with your hands, components, screws, or any other tools.
- During operation, do not touch heat sink area with bare hands as the inverter surface may become hot.



#### CAUTION

##### Risk of equipment damage and personal injury

If you detect any unusual odors, hear abnormal noises, or notice smoke during operation, immediately shut down the unit and disconnect all power sources.



#### NOTICE

##### Risk of equipment malfunction and safety hazards

Failure to follow proper guidance and neglect of regular monitoring prevents the timely identification and prevention of potential issues.

- Read the entire user manual before installation and keep it at hand for future reference.
- Regularly check the status via the monitoring interface to promptly detect any abnormalities.

## Electrical Safety

### DANGER

#### Risk of high voltage and electric shock

Before any operation, disconnect the inverter from all AC and DC power sources and wait at least 5 minutes to allow internal capacitors to discharge.

### WARNING

#### Risk of overheating, fire and equipment damage

Obstructing ventilation or allowing foreign objects to enter the equipment may lead to fire hazards.

- During operation, ensure that the ventilation vents or heat dissipation systems are not obstructed or covered by other objects to prevent fire due to high temperature.
- During operation, prevent foreign matter from entering the equipment. Otherwise, equipment short-circuits or damage, load power derating, power failure, or personal injury may occur.

## Environment Requirements

### DANGER

#### Risk of severe electrical shock

A lightning strike can induce a sudden and massive power surge, which poses severe hazard to both personnel and equipment.

Installation, operation, and maintenance is prohibited during thunderstorms.

### CAUTION

Do not place any foreign objects or liquid containers on the inverter.

## Mechanical Safety













### NOTICE

#### Risk of equipment failure or physical injury

Installing or operating an inverter with pre-existing physical damage compromises safety and functionality.

- Before unpacking the inverter, check the outer packing materials for damage, such as holes and cracks, and check the inverter model. If any damage is found or the inverter model is not what you requested, do not unpack the package and contact your supplier as soon as possible.
- Before installation, inspect the equipment for any visible damage or signs of transportation damage. If damage is found, do not install or use the equipment.

## 1.2. Safety symbols

Symbol	Description
	<b>Danger:</b> Electrical shock hazard This device is directly connected to public grid and thus all work to the system shall only be carried out by qualified personnel.
	<b>Danger:</b> Hot surface The components inside the battery will release a lot of heat during operation. Do not touch metal plate housing during operating.
	<b>Danger:</b> Risk of electric shock from energy stored in capacitor. Do not open the cabinet door until 5 minutes after disconnecting all sources of supply.
	<b>Warning:</b> No open flames Do not place or install near flammable or explosive materials.
	<b>Caution</b> Keep the product out of reach of children.
	<b>Caution:</b> Check the user manual before service If an error has occurred, refer to the troubleshooting instructions to remedy the error.
	<b>Caution</b> This device shall NOT be disposed of in residential waste.
	<b>Caution</b> This battery module shall NOT be disposed of in residential waste.
	<b>CE Mark</b> Equipment with the CE mark fulfills the requirements of the Low Voltage Directive and Electro Magnetic Compatibility.
	<b>RoHS compliant mark</b> Equipment with the RoHS mark does not exceed the allowable amounts of the restricted substances defined in Restriction of Hazardous Substances in Electrical and Electronic Equipment.
	<b>RCM compliant mark</b> Equipment with the RCM mark is in compliance with AS/NZS 4417.1 & 2 and the EESS.
	<b>Recyclable</b>

## 2. Product information

### 2.1. Product introduction

CH3 series are hybrid photovoltaic inverters applicable to both on-grid and off-grid solar systems. The energy generated by the PV system is fed to the loads first, and then the surplus energy can charge the battery for later use. More energy produced by the PV system can be exported to the grid.

CH3 series inverters can significantly improve the self-consumption rate of the solar energy and reduce grid dependency.

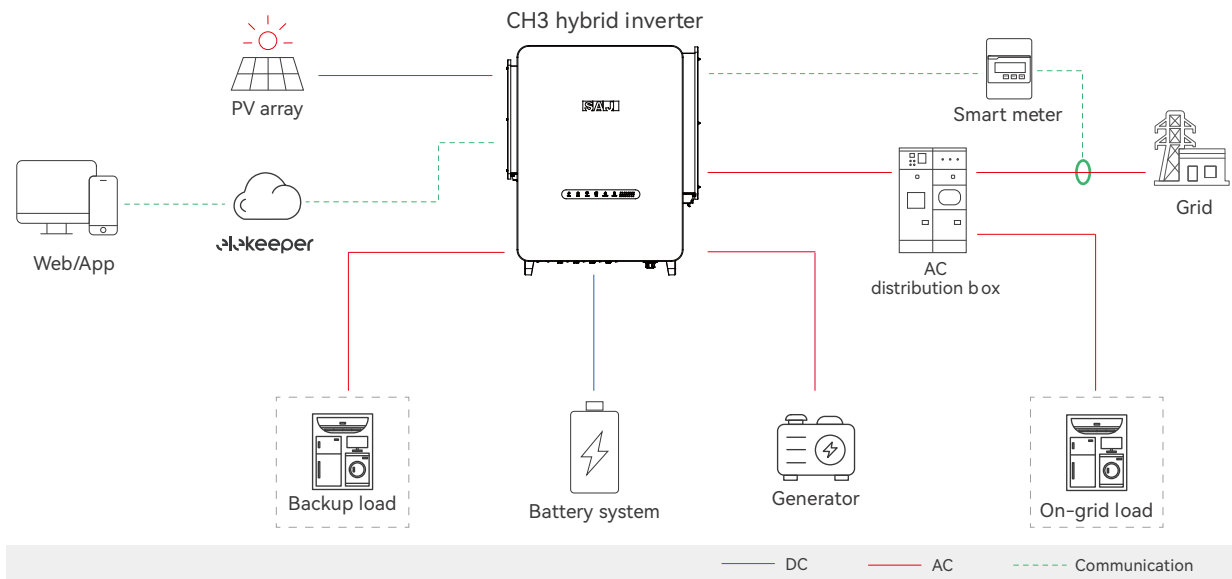

Figure 2.1. System overview

#### 2.1.1. Model description

Take **CH3-125K-T8-EU** as an example:

**CH3-125K-T8-EU**

①                      ②                      ③                      ④

- ① The product series.
- ② The rated power of the hybrid inverter in kW. The value includes 75, 80, 99.9, 100, 110, and 125.
- ③ T8 means three phases with 8 MPPTs. The value includes T6 and T8.
- ④ For European countries.

#### Product models

- CH3-75K-T6-EU
- CH3-80K-T6-EU
- CH3-99.9K-T8-EU
- CH3-100K-T8-EU

- CH3-110K-T8-EU
- CH3-125K-T8-EU
- CH3-75K-T6-G-EU
- CH3-80K-T6-G-EU
- CH3-99.9K-T8-G-EU
- CH3-100K-T8-G-EU
- CH3-110K-T8-G-EU
- CH3-125K-T8-G-EU

**Note:** The -G models are grid-tied inverters that only provide grid integration at AC side.

### 2.1.2. Dimensions

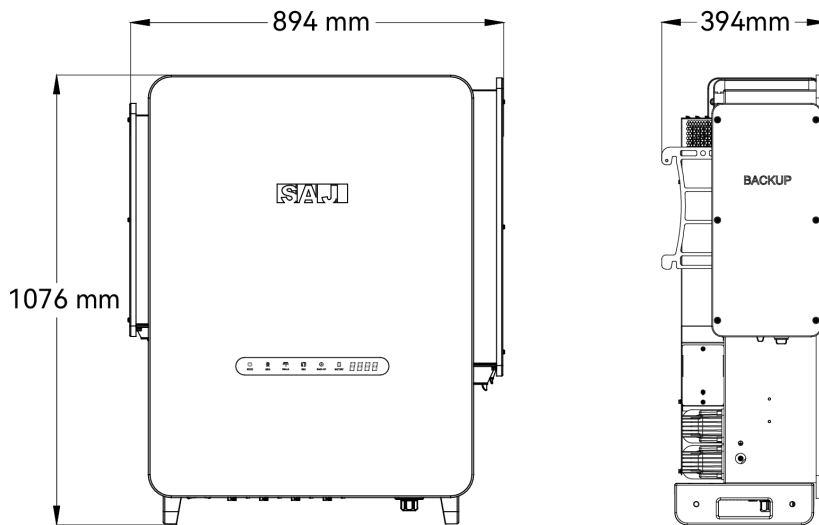

### 2.1.3. Electrical terminals

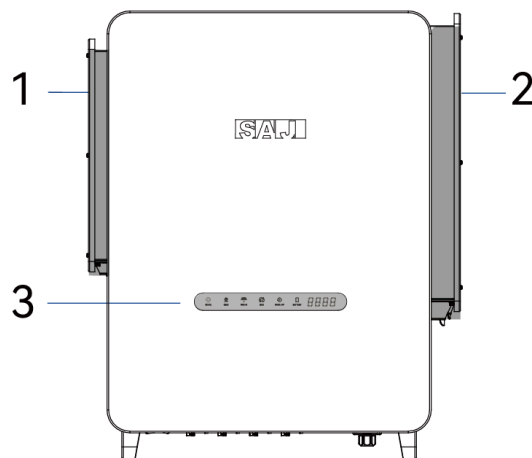

Figure 2.2. Front view

Callout	Silkscreen	Description
1	<b>BACKUP</b>	The AC connection box for backup connections.
2	<b>GRID/GEN</b>	The AC connection box for grid and generator connections.
3	LED panel	The LED panel. For detailed indicators, see <a href="#">Table 2.1. LED Indicators (on page 8)</a> .









LED	Status	Description
 <b>STATE</b>	Solid green	Inverter is working.
	Breathing green	Inverter is initializing or standby.
	Solid red	Inverter is faulty.
	Breathing red	Fire alarm or fatal error.
	Breathing yellow	Inverter is upgrading.
	Off	Inverter powers off.
 <b>GRID</b>	Solid on	Connected to grid.
	On 1s, off 1s	Counting down to grid connection.
	On 1s, off 3s	Grid is faulty.
	Off	No grid connection.
 <b>SOLAR</b>	Solid on	PV array is working.
	On 1s, off 1s	PV array is faulty.
	Off	PV array is not working.
 <b>GEN</b>	Solid on	Power input is connected.
	Off	Generator is disconnected.
 <b>BACK-UP</b>	Solid on	Backup-side is running.
	On 1s, off 1s	Backup-side is overloaded.
	Off	Backup-side load is disconnected.
 <b>BATTERY</b>	Solid on	The battery is discharging or inactive.
	On 1s, off 1s	The battery is charging.
	On 1s, off 3s	Low SOC.
	Off	Disconnected or communication lost.
	 <i>P-integer</i>	Battery SOC.
 <i>E-integer</i>	Error code. <ul style="list-style-type: none"> <li>When urgent alarms are reported, the indicator shows the latest three urgent alarms in rotation.</li> <li>When no urgent alarms are reported, the indicator shows the battery SOC and the latest three important or commonly alarms in rotation.</li> </ul>	
----	The inverter lost all communication or is inactive.	

Table 2.1. LED Indicators

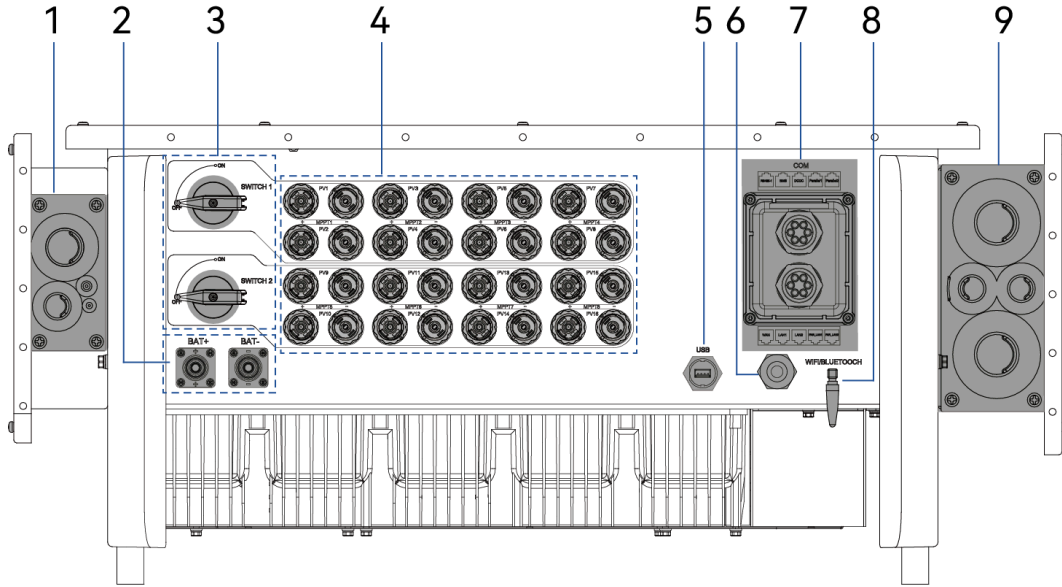

Figure 2.3. Bottom view

Callout	Silkscreen	Description
1	/	The cable entry for AC backup connections.  Four cable entries of the following diameters are available: <ul style="list-style-type: none"> <li>• 10 mm</li> <li>• 15 mm</li> <li>• 35 mm</li> <li>• 54 mm</li> </ul>
2	<b>BAT+, BAT-</b>	The battery connection ports.
3	<b>SWITCH 1, SWITCH 2</b>	The PV switch. Switch 1 controls PV1 to PV8, while Switch 2 controls PV9 to PV16.
4	<b>PV1-PV16</b>	The PV connection ports.
5	<b>USB</b>	The USB connection port.
6	/	The temperature sensor.
7	<b>COM</b>	The communication connection ports.
8	<b>WIFI/BLUETOOTH</b>	The Wi-Fi adapter connection port.
9	/	The cable entry for grid and generator AC connections.  Four cable entries of the following diameters are available: <ul style="list-style-type: none"> <li>• 40 mm x2</li> <li>• 70 mm x2</li> </ul>

### 2.1.4. Communication terminals

The following figure shows the systems and devices that can be connected to the CH3 inverter.

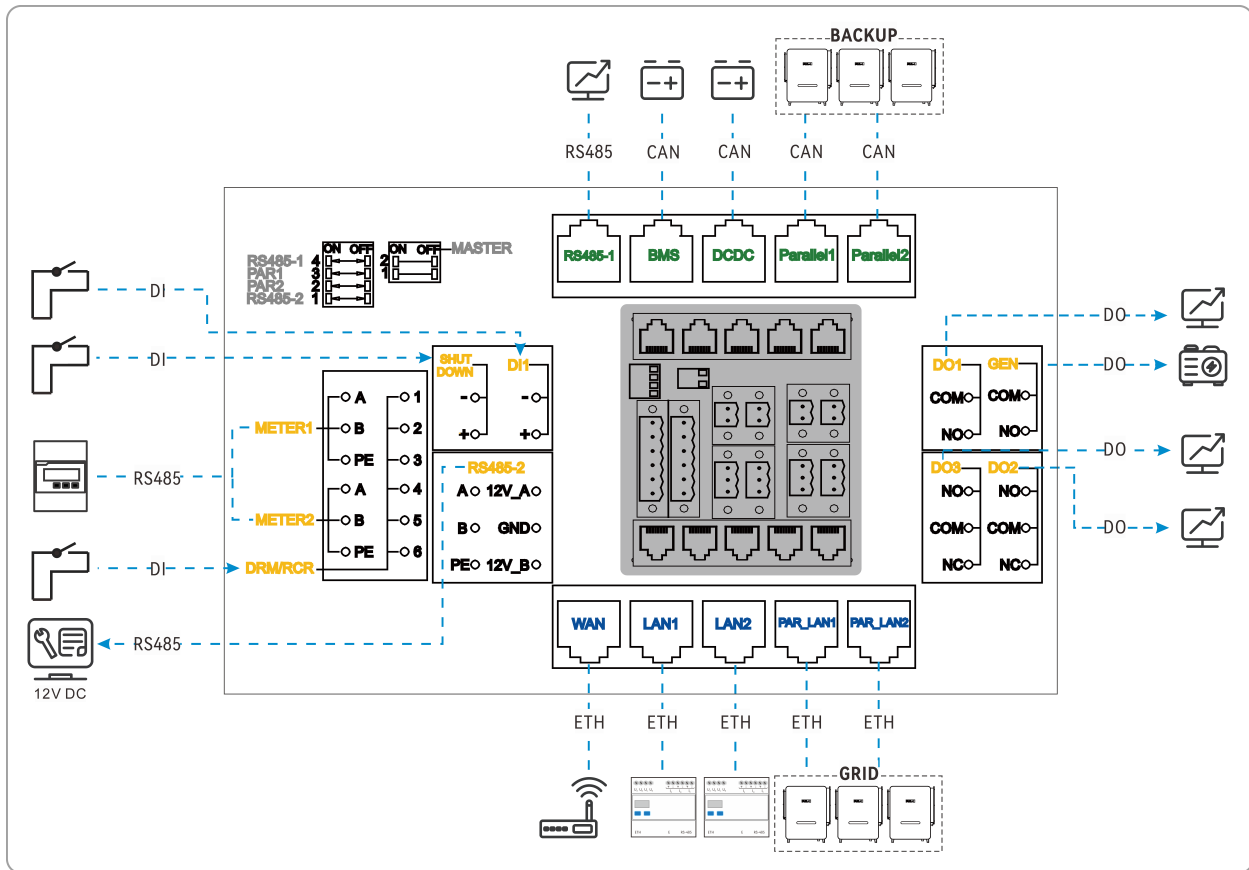

Figure 2.4. CH3 communication connection overview

Terminal type	Silkscreen	Communication protocol	Description
RJ45	<b>RS485-1</b>	RS485	For connecting external monitoring or communication devices through RS485 communication.
RJ45	<b>BMS</b>	CAN	For CAN communication with lithium battery.
RJ45	<b>DCDC</b>	CAN	Reserved for connecting with battery DC/DC communication module.
RJ45	<b>Parallel 1 Parallel 2</b>	CAN	For inverter communication in parallel deployment with backup connections enabled.
3-pin connector	<b>METER1</b>	RS485	For data collection from the public grid through RS485 communication for functions like export limit control.
3-pin connector	<b>METER2</b>	RS485	For additional meter connection through RS485 communication.
6-pin connector	<b>DRM/RCR</b>	DI	For demand response modes (DRM) or ripple control receiver (RCR) devices connection.
2-pin connector	<b>SHUTDOWN</b>	DI	For external DI connections to shut down the inverter in emergency situations.
2-pin connector	<b>DI1</b>	DI	General-purpose digital signal input, programmable for specific control logic.

Terminal type	Silkscreen	Communication protocol	Description
3-pin connector	<b>RS485-2</b>	RS485	For providing RS485 communication and 12V DC output. This terminal can be connected with devices like external PV fast shutdown switch, or for providing 12V DC power supply to external devices.
2-pin connector	<b>DO1</b>	DO	Reserved NO dry output terminal 1 for programmable relay output.
2-pin connector	<b>GEN</b>	DI	For DI connection with diesel generator.
3-pin connector	<b>DO3</b>	DO	Reserved NO dry output terminal 3 for programmable relay output.
3-pin connector	<b>DO2</b>	DO	Reserved NO dry output terminal 2 for programmable relay output.
RJ45	<b>WAN</b>	ETH	For connecting with the router, allowing the inverter to connect to the cloud platform.
RJ45	<b>LAN1</b>	ETH	For LAN connection with the inverter smart meter.
RJ45	<b>LAN2</b>	ETH	For additional LAN connection with the inverter smart meter.
RJ45	<b>PAR_LAN1</b>	ETH	For inverter data synchronization in parallel deployment.
RJ45	<b>PAR_LAN2</b>		

Table 2.2. CH3 communication terminals

See the RJ45 pin descriptions below:

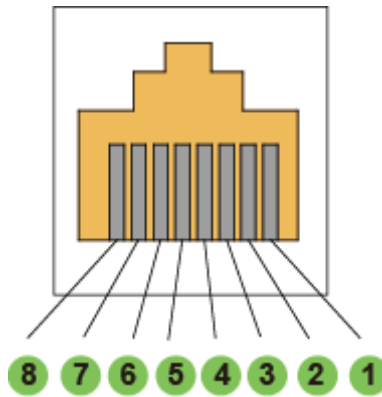

RS485-1		BMS		DCDC		Parallel1		Parallel2	
1	NC	1	Shut down_BMS	1	RES_DCDC_SYNB	1	Carrier SYN B	1	Carrier SYN B
2	NC	2	GND_S	2	RES_DCDC_SYNA	2	Carrier SYN A	2	Carrier SYN A
3	NC	3	NC	3	NC	3	Power freq SYN B	3	Power freq SYN B
4	NC	4	BMS_CANH	4	NC	4	Reserved SYN B	4	Reserved SYN B
5	NC	5	BMS_CANL	5	NC	5	Reserved SYN A	5	Reserved SYN A
6	NC	6	NC	6	NC	6	Power freq SYN A	6	Power freq SYN A
7	RES_RS485_A	7	NC	7	BAT_CANL	7	SYNC_CANL	7	SYNC_CANL
8	RES_RS485_B	8	NC	8	BAT_CANH	8	SYNC_CANH	8	SYNC_CANH
WAN		LAN1		LAN2		PAR_LAN1		PAR_LAN2	
1	TX+	1	TX1+	1	RX2+	1	RX3+	1	TX4+
2	TX-	2	TX1-	2	RX2-	2	RX3-	2	TX4-
3	RX+	3	RX1+	3	TX2+	3	TX3+	3	RX4+
4	NC	4	NC	4	NC	4	+22V_S1	4	+22V_S1
5	NC	5	NC	5	NC	5		5	
6	RX-	6	RX1-	6	TX2-	6	TX3-	6	RX4-
7	NC	7	NC	7	NC	7	GND_S	7	GND_S
8	NC	8	NC	8	NC	8		8	

Table 2.3. RJ45 pin definitions

## 2.2. Grid integration types

CH3 series systems support the following grid configurations:

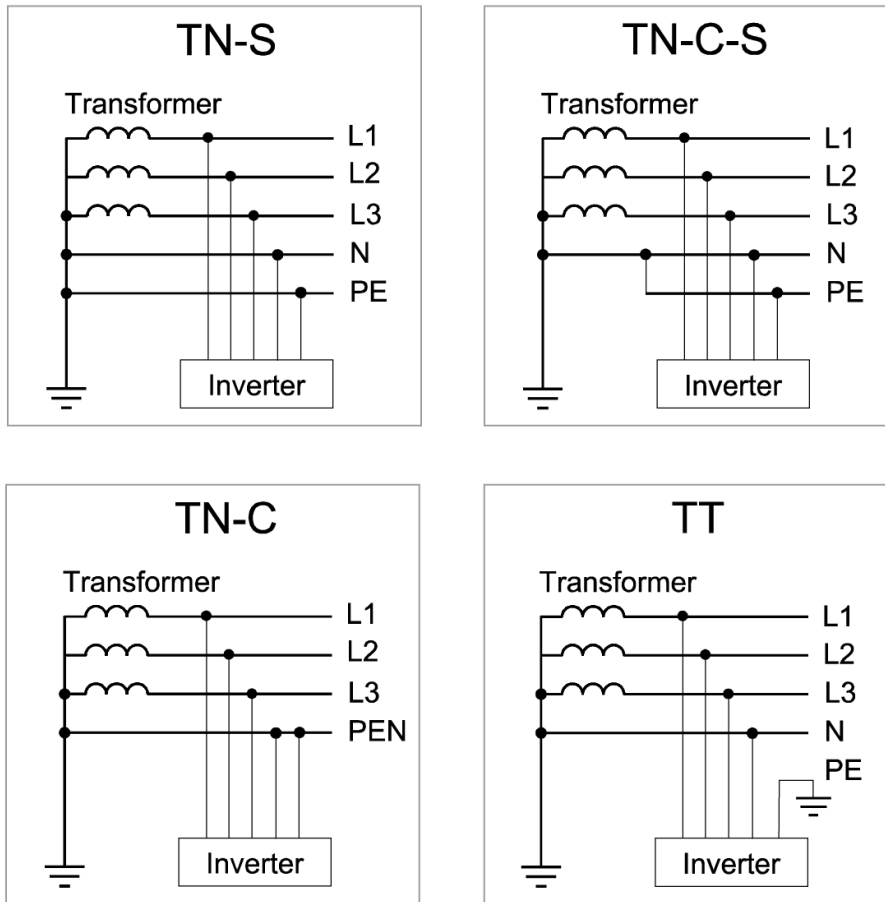

### 2.3. Work mode

CH3 series systems support the following working modes:

#### AI Mode

The working mode operates with AI Saving enabled. The system leverages AI-powered intelligent scheduling based on forecasts of PV generation, load demand, and electricity pricing to optimally allocate energy sources and usage, minimizing electricity bills and maximizing grid-export revenue.

#### Maximum Self-Consumption

When solar power is sufficient, the electricity generated by the PV system is first supplied to the load. Any surplus energy is stored in the battery, and excess electricity is then exported to the grid. When solar power is insufficient, the battery discharges to supply power to the load.

#### Time-of-Use (TOU) Mode

In the time-of-use (TOU) mode, the battery charges or discharges during the set period. For the other periods, the battery works in the max self-consumption mode.

In this mode, advanced settings like back-mode and peak shaving are available for various power consumption requirements and local grid policies.

#### Micro-Grid Mode

The PV system only supplies power to the loads until the battery reaches the set SOC value. In this case, the system can start up the diesel generator automatically to supply power to the battery and the loads.

**Virtual Power Plant (VPP) Mode**

In this mode, the system works according to the scheduling strategy from the VPP platform and related controllers.

### 3. Transportation and storage

#### DANGER

- Observe all safety symbols displayed on the packaging prior to transportation.
- Maintain stable driving conditions throughout transportation to prevent the inverter from colliding or dropping. Otherwise, the internal power components may be damaged, potentially causing short circuits or explosions upon subsequent power-up.
- Ensure that transport vehicles are not overloaded and that weight is distributed evenly.
- Do not drill holes into the product or its housing for any transportation-related purpose. Such modifications can damage the structural integrity and functionality of the device.
- Do not store or transport the equipment in damp, flammable, or explosive environments.

#### WARNING

- When moving the equipment, use the original packaging or dedicated handling tools to avoid muscle strain from lifting heavy objects alone.
- Wear suitable protective gloves when manually handling equipment.
- When lifting the inverter, grip it firmly at the designated handles and support the base. Keep the unit level to avoid dropping.
- Do not unpack the inverter packaging if it is not used immediately.
- Do not store the inverter in areas exposed to direct sunlight, rain, strong electric fields, or high humidity. Such conditions can cause overheating, electrical failure, or corrosion.
- Do not store inverters near chemically corrosive substances or in locations prone to pests or rodents. These can cause irreversible damage to housing and internal components.
- Do not stack heavy objects on top of the inverter enclosure during storage.
- Do not tilt or invert the packaging. Maintain the upright orientation as indicated on the carton to prevent internal displacement or component stress.

#### CAUTION

- The storage temperature must remain between  $-30^{\circ}\text{C}$  and  $+60^{\circ}\text{C}$  ( $-22^{\circ}\text{F}$  to  $+140^{\circ}\text{F}$ ), with relative humidity between 5% and 95% (non-condensing).
- Store inverters in a clean, dry, and well-ventilated area to avoid moisture buildup and overheating.
- Promptly replace any packaging materials that have been damaged by insects or rodents.

#### NOTICE

- It is recommended to retain the original packaging for future relocation or return for repair.
- Before long-term storage (exceeding 6 months), ensure the storage environment meets requirements and periodically inspect the packaging integrity. Check for environmental damage, pest intrusion, or packaging degradation.

#### 3.1. Transportation equipment

The installers need to prepare proper equipment for transporting and lifting the product.

### Forklift

Use a forklift to move or lift the inverter with package. Keep no more than four inverters in one stack during transportation.

The forklift must meet the following requirements:

- The load capacity must be greater than one ton.
- The length of the fork blades must be greater than 1.2 meters. Use fork extensions if needed.
- The fork blades can slide under the bottom of the stack for lifting and moving.

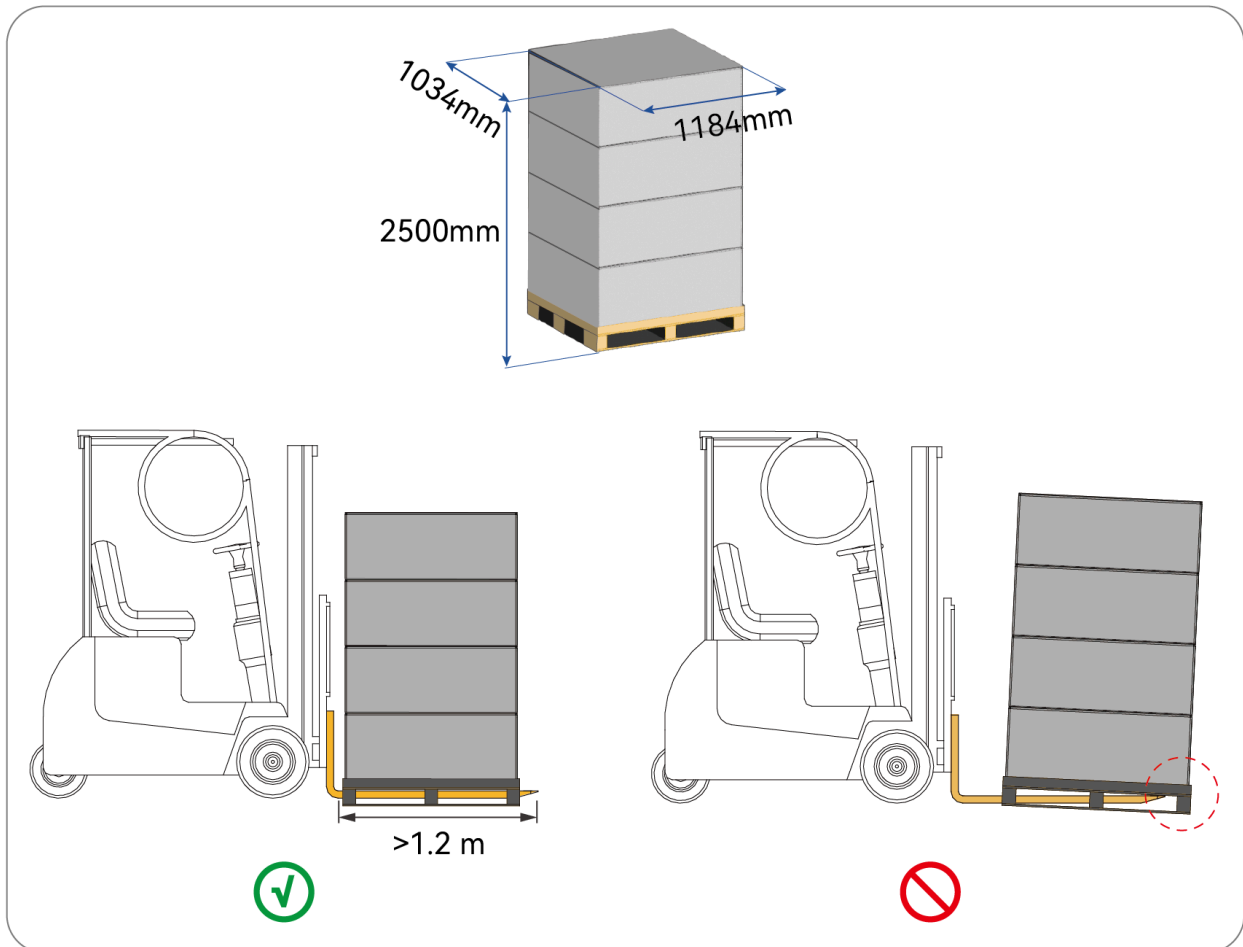

Figure 3.1. Moving with forklift

## 4. Installation instructions

### 4.1. Installation Preparation

Read the following sections to determine the installation site.

The safety regulations vary in different countries and regions. Follow local safety regulations.

#### 4.1.1. Precautions

For safety, be sure to read all the safety instructions carefully prior to any work and observe the appropriate rules and regulations of the country or region where you install the product.



#### DANGER

**Danger to life due to potential fire or electric shock.**

Do not install the product near any inflammable or explosive items.



#### NOTICE

**This equipment meets the pollution degree.**

- Inappropriate or the harmonized installation environment may jeopardize the life span of the product.
- The installation site must be well ventilated.

#### 4.1.2. Installation environment requirement

It is strongly suggested to install the product in an outdoor location that is more than 2000 meters from the coast. When selecting the installation location, follow the guidelines below:

- Consult the dealer or **SAJ** technical support when the distance from the installation location to the coast is between 500 and 2000 meters. Do not install the product within 500 meters from the coast.
- Do not install the product in areas affected by salt damage or pollution which can lead to corrosion of the equipment.
- Do not install the product in areas with moderate or heavy dust pollution, metallic dust pollution, saline-alkali land, corrosive gas pollution, or corrosive rainwater pollution.
- The installation environment must be free of inflammable or explosive materials.
- The product must be installed in a place away from any heat source.
- Do not install the product at a place where the temperature changes extremely.
- The height of the product from the ground should be considered to prevent the equipment from soaking in water. The specific height is determined by the site environment.

#### 4.1.3. Plan the installation site

1. Install the inverter vertically. Do not install it backward-tilted, forward-tilted, or horizontally.

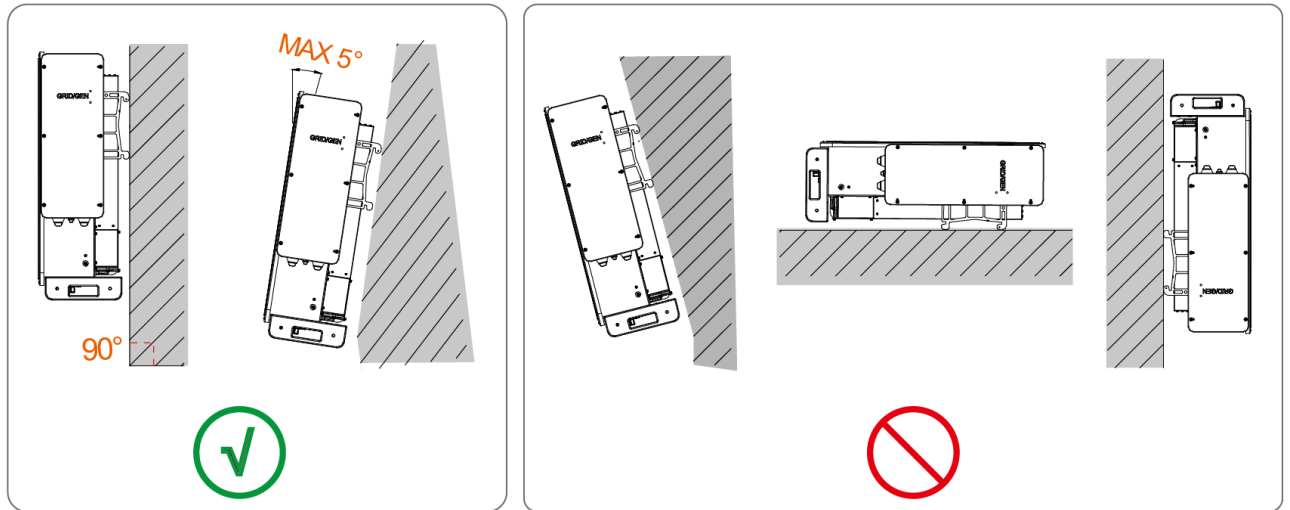

2. This device is cooled by natural convection and suggested an indoor installation or an installation under a sheltered place to prevent the product from exposure to direct sunlight, rain and snow erosion.
3. Poor air ventilation will affect the working performance of internal electronic components and shorten the service life of the system. Reserve enough clearance around the product to ensure a good air circulation at the installation area.

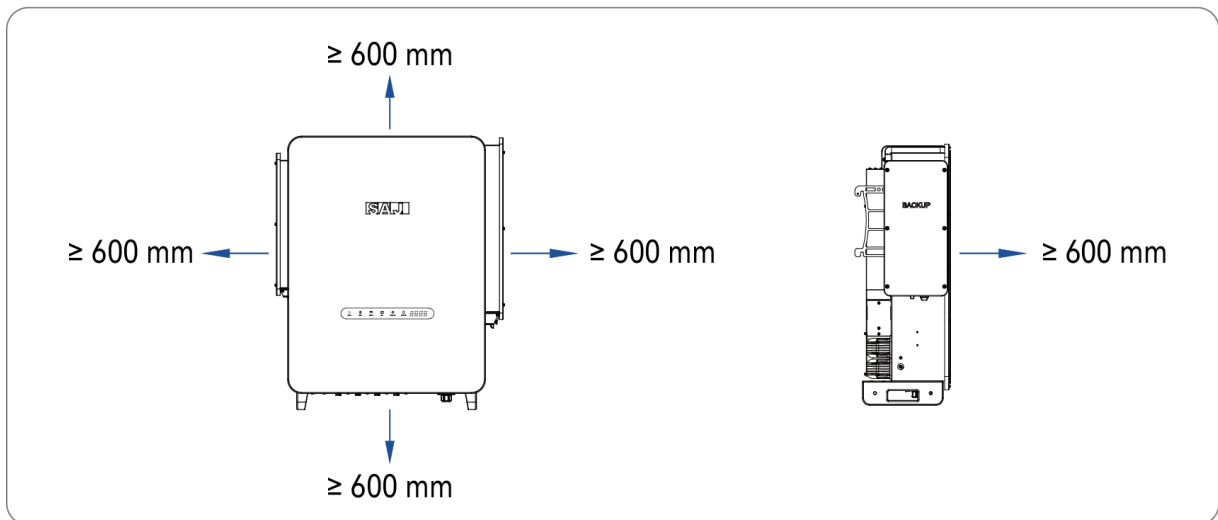

4. In parallel deployment, arrange the inverters as follows:

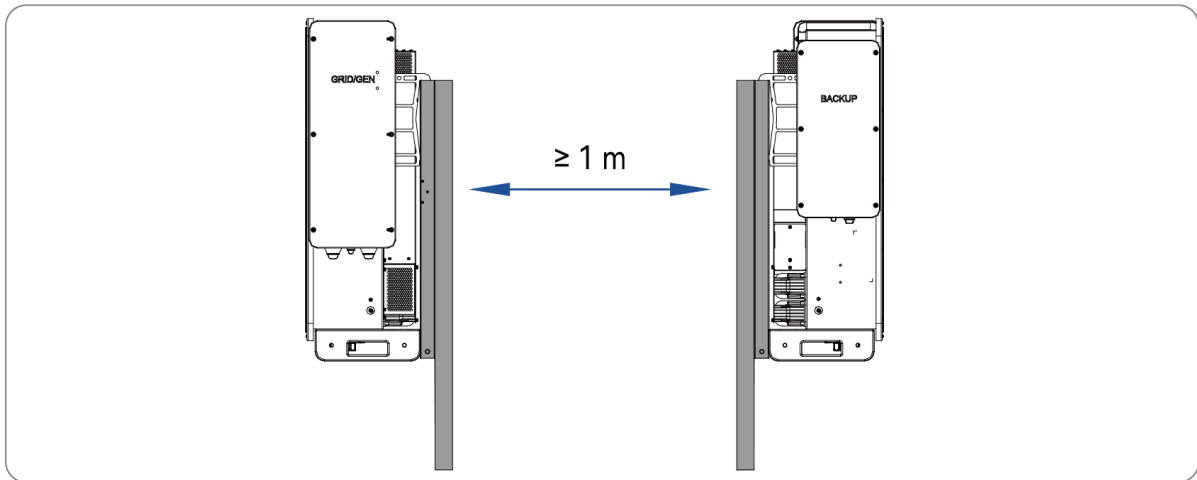
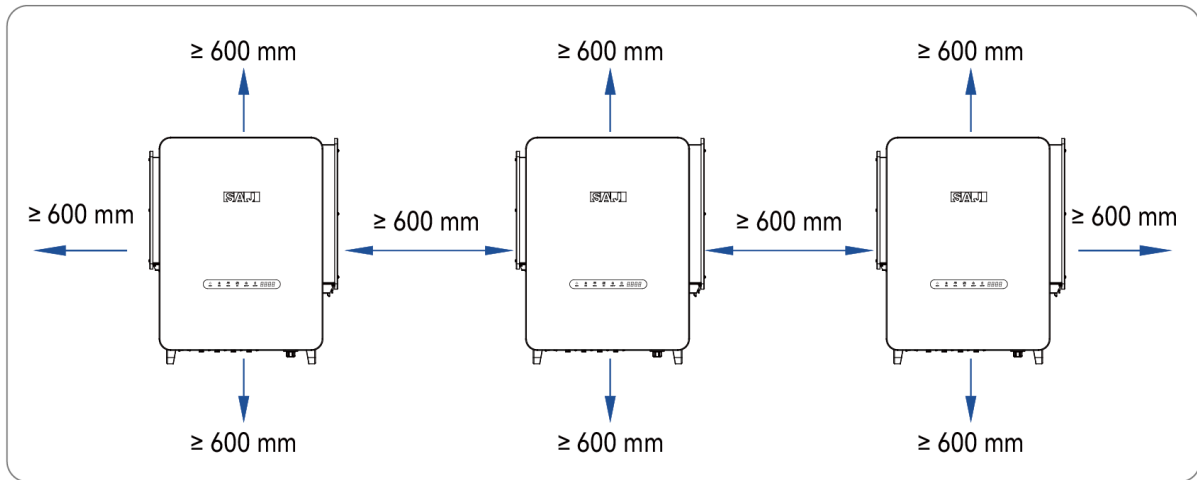

#### 4.1.4. Lifting equipment

During the installation, use a crane to lift and move the inverter.

Follow the safety instructions below when using the crane:

- The load capacity of the crane must be larger than one ton; the slings must be strong enough to lift and move the inverter.
- Recommend using fiber slings to avoid scratching the painting on the inverter surface.

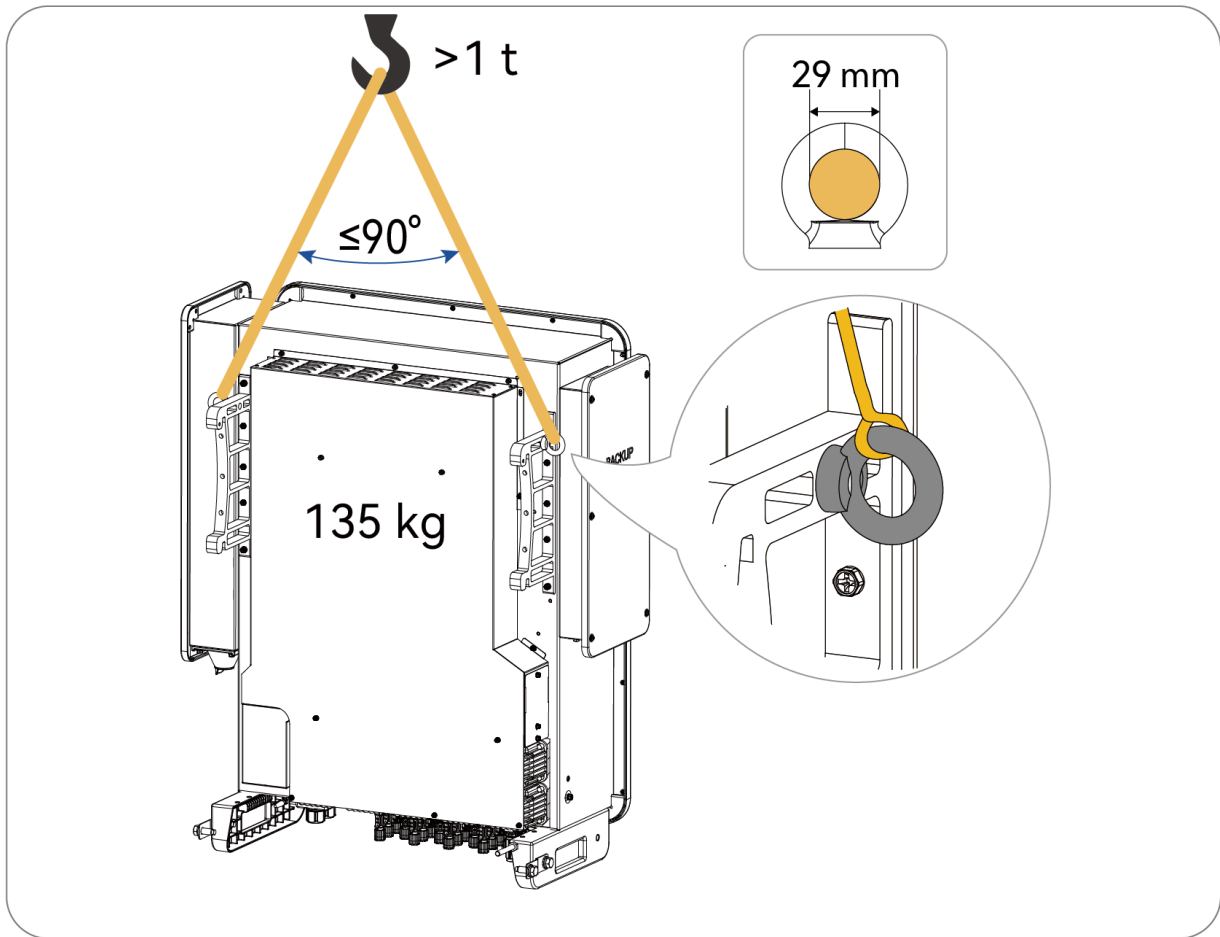

Figure 4.1. Lifting equipment

### 4.1.5. Installation tools

Installation tools include but are not limited to the following recommended ones. Use other auxiliary tools on site if necessary.

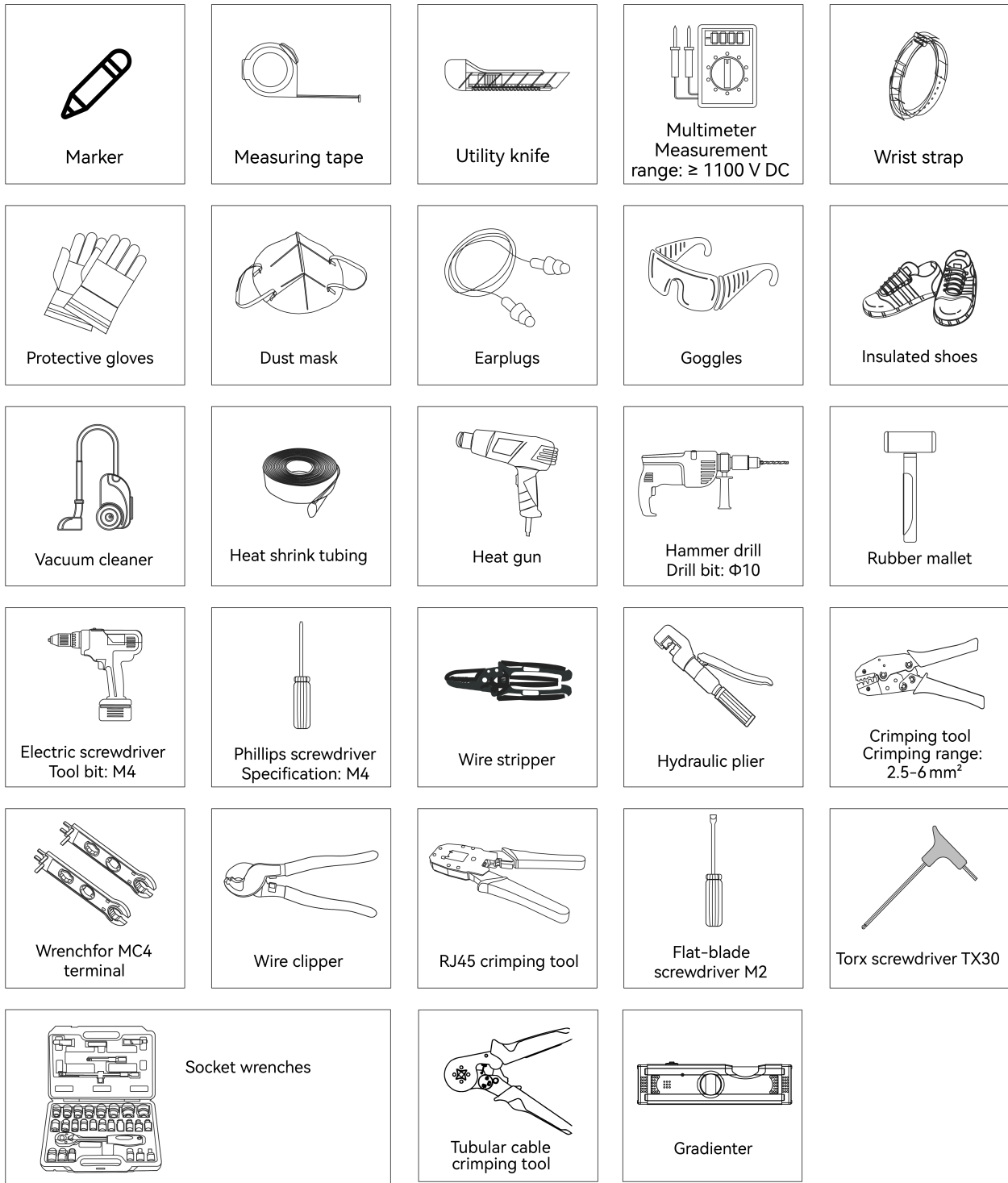
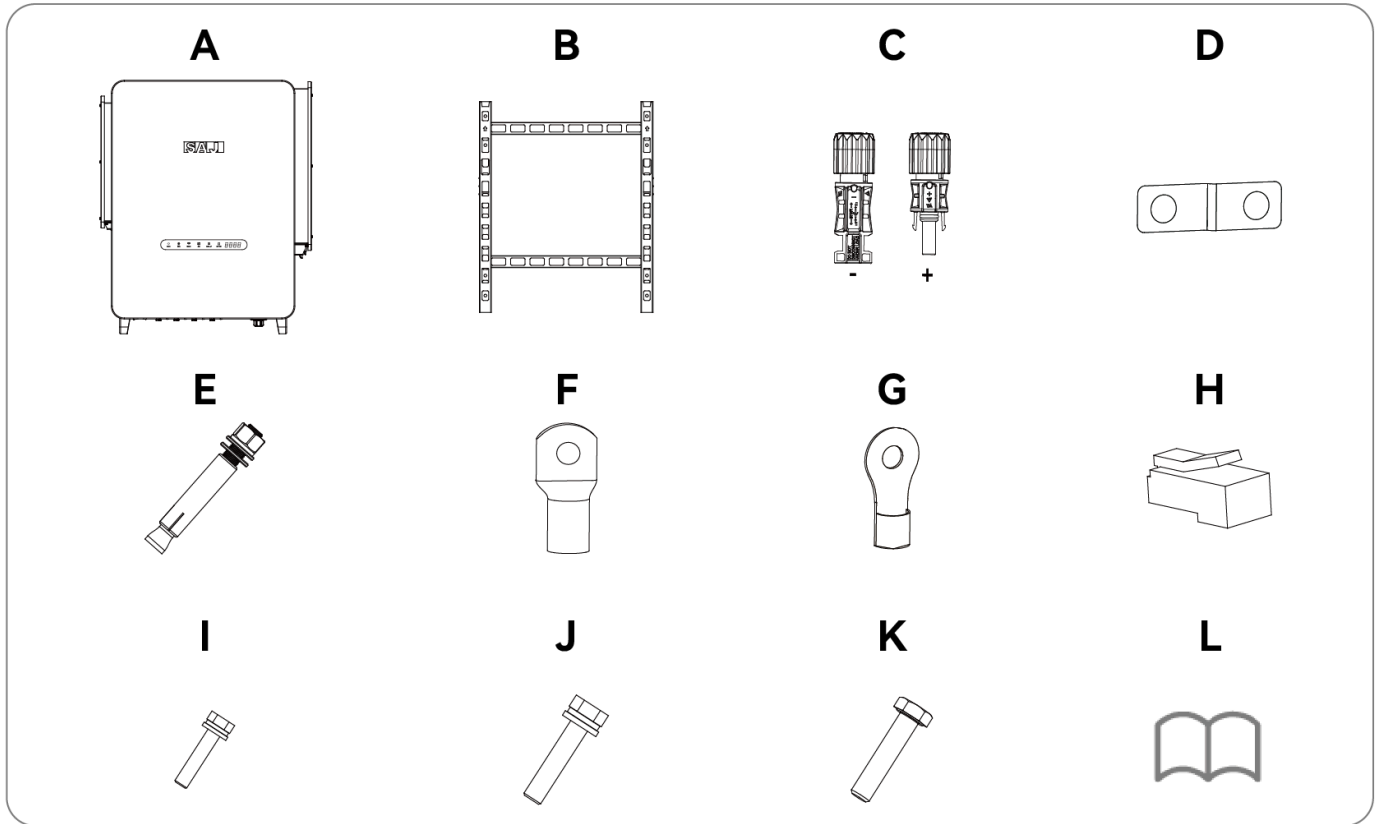

Figure 4.2. Suggested installation tools

#### 4.1.6. Packing list



Number	Quantity	Designation
A	1	CH3 inverter (135 kg)
B	1	Mounting bracket (3.8 kg)
C	<ul style="list-style-type: none"> <li>• T6 models: 12 pairs</li> <li>• T8 models: 16 pairs</li> </ul>	PV positive and negative connector
D	2	Connecting plate
E	4	M10*100 expansion bolt
F	<ul style="list-style-type: none"> <li>• SC25-10: 12</li> <li>• SC70-10: 12</li> <li>• SC150-10: 12</li> </ul>	AC cable OT terminal
G	2	RNB38-8 grounding cable OT terminal
H	10	RJ45 communication cable connector
I	2	M6*12 screw
J	4	M12*20 screw
K	4	M10*45 screw
L	1	Document

#### 4.2. Mount the inverter

Select one of the following options to mount the inverter:

- Mount the inverter on the wall.
- Mount the inverter on a frame. With this option, the installer needs to prepare the frame that can bear the weight of the inverter. Four M10\*100 screws are provided in the delivery for securing the mounting bracket to the frame.

### 4.2.1. Mount the inverter on wall

Follow this procedure to mount the inverter on the wall.



**CAUTION**

Make sure that the wall can bear the weight of the inverter and the accessories.

**Procedure**

1. Select one of the four mounting options for securing the bracket to the wall. Mark four drilling holes accordingly.

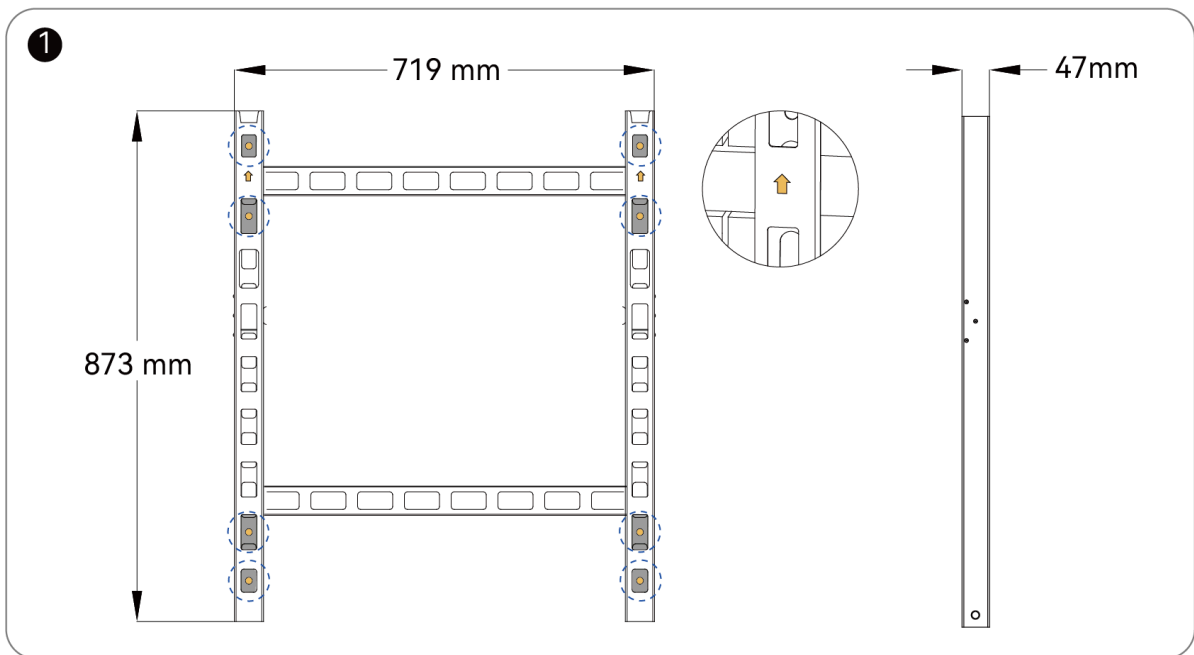
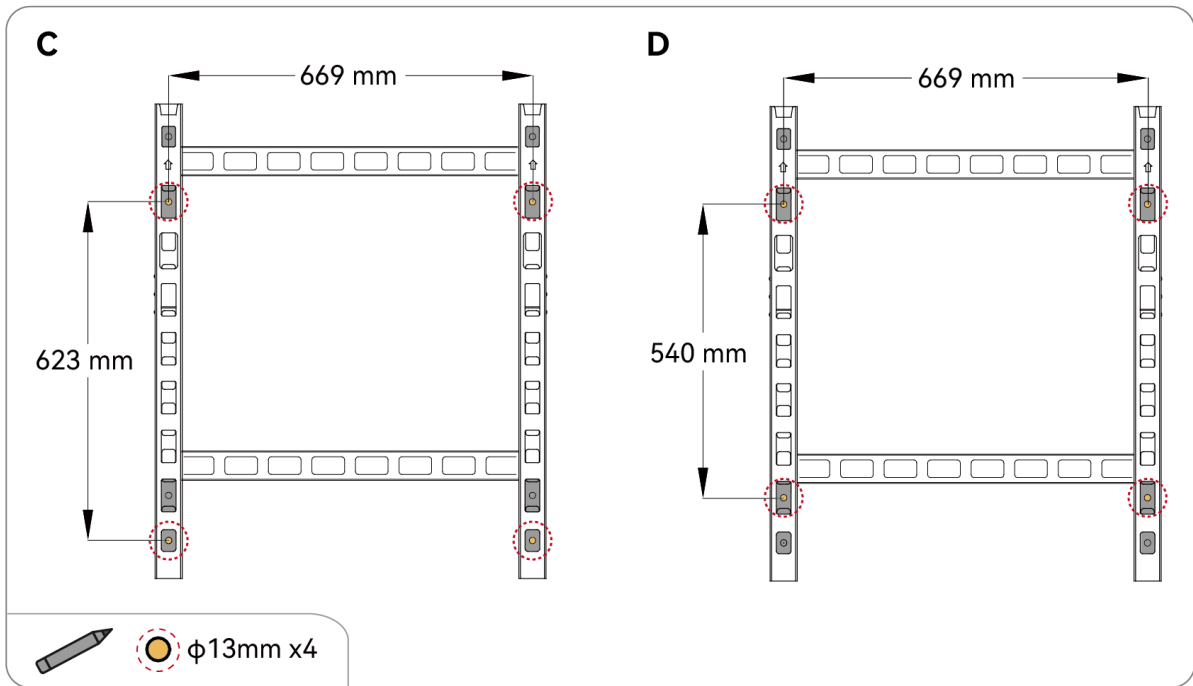
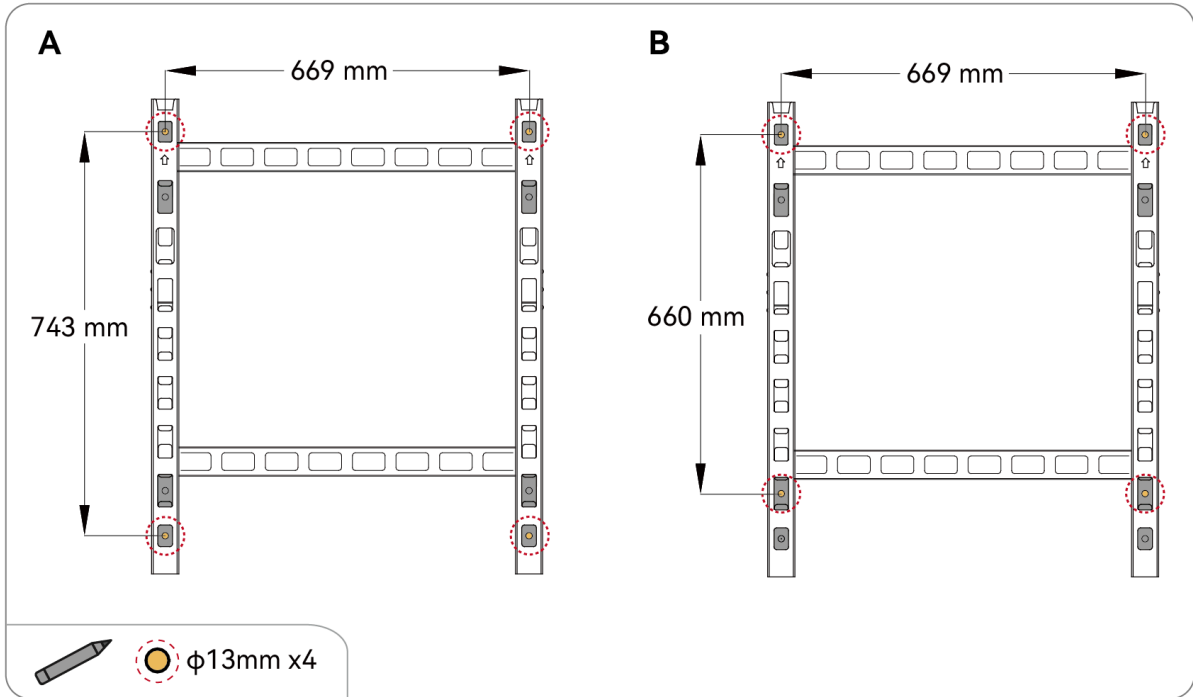

Figure 4.3. Mounting bracket size

**Mounting options:**

**Note: Recommended: Option A.**



2. Drill four holes on the wall. Take option A as an example:

**Example:**

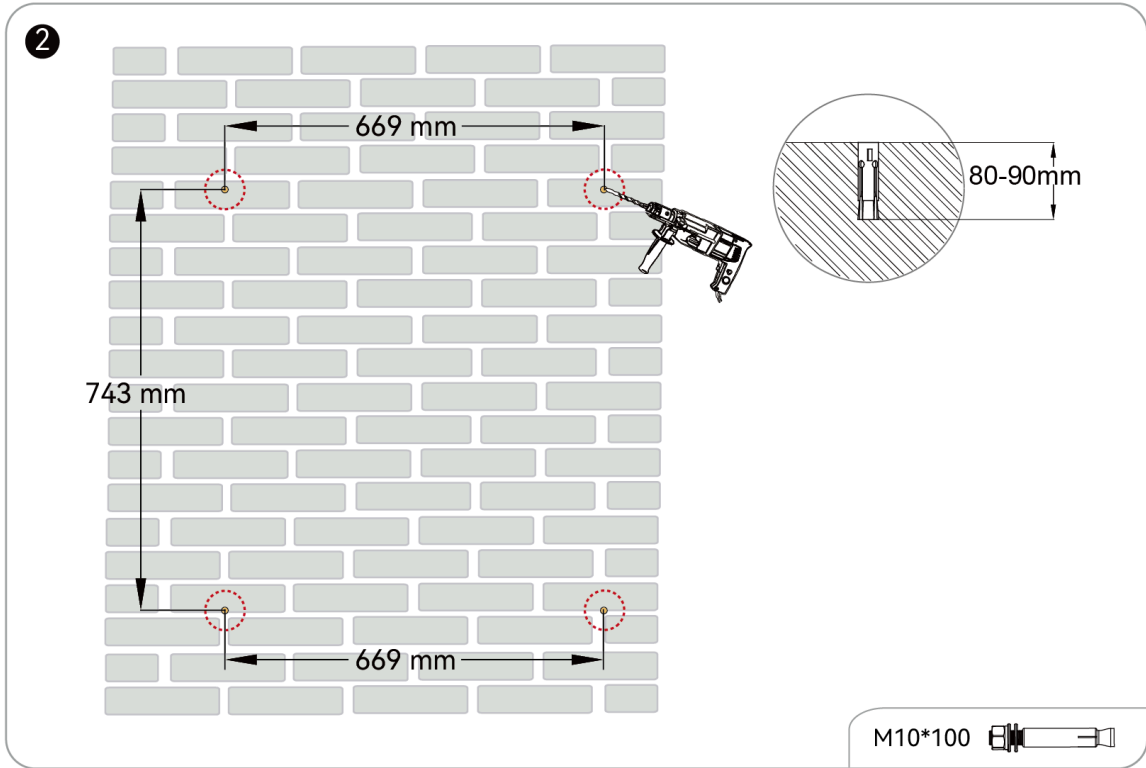

3. Secure the mounting bracket to the wall with four screws.

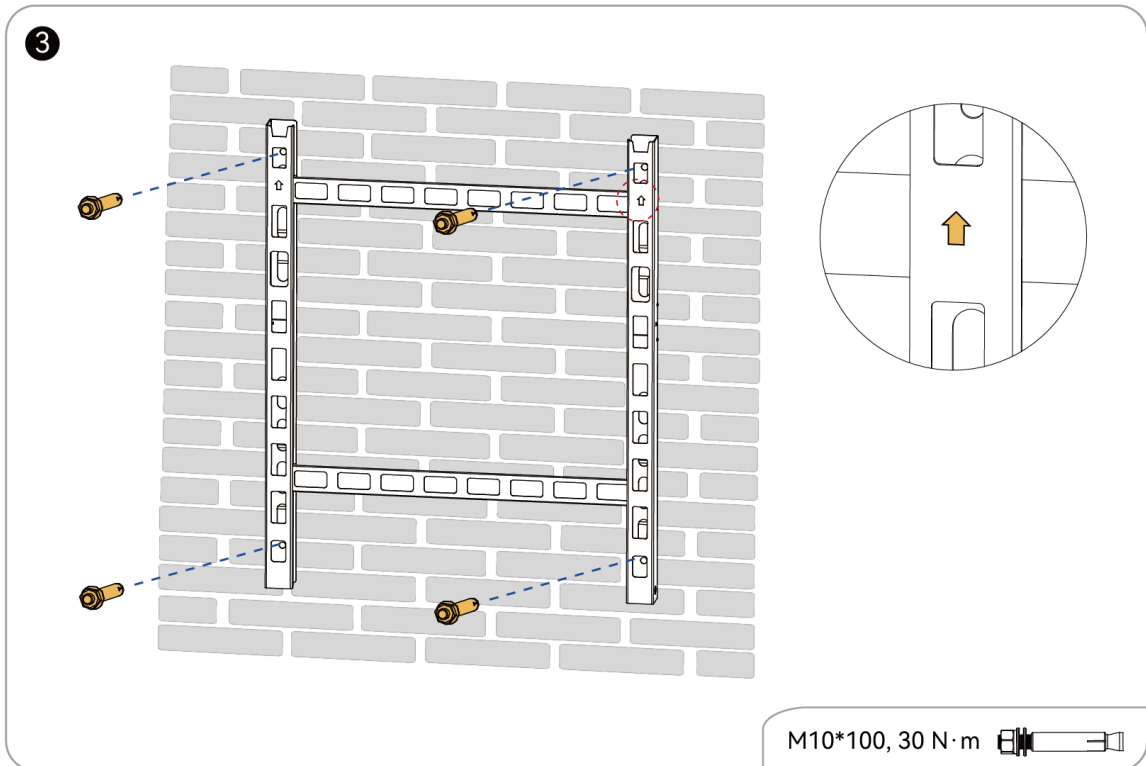

4. Mount the inverter onto the bracket.

**Note:** Make sure that the inverter bottom is firmly placed against the bracket.

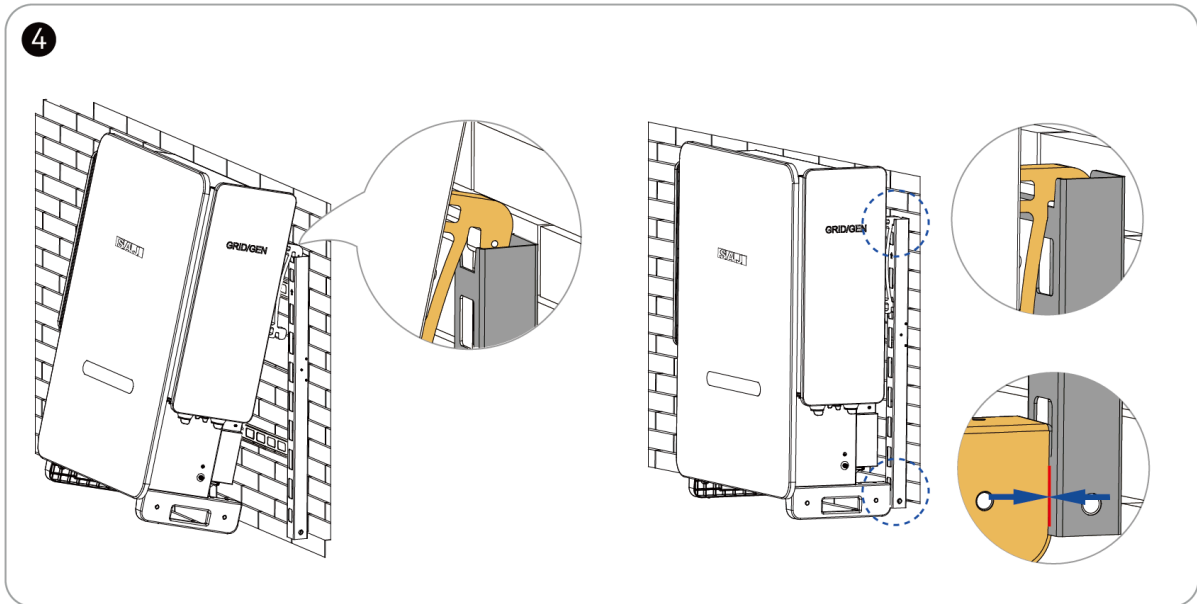

5. Install the metal plate to secure the inverter to the bracket.

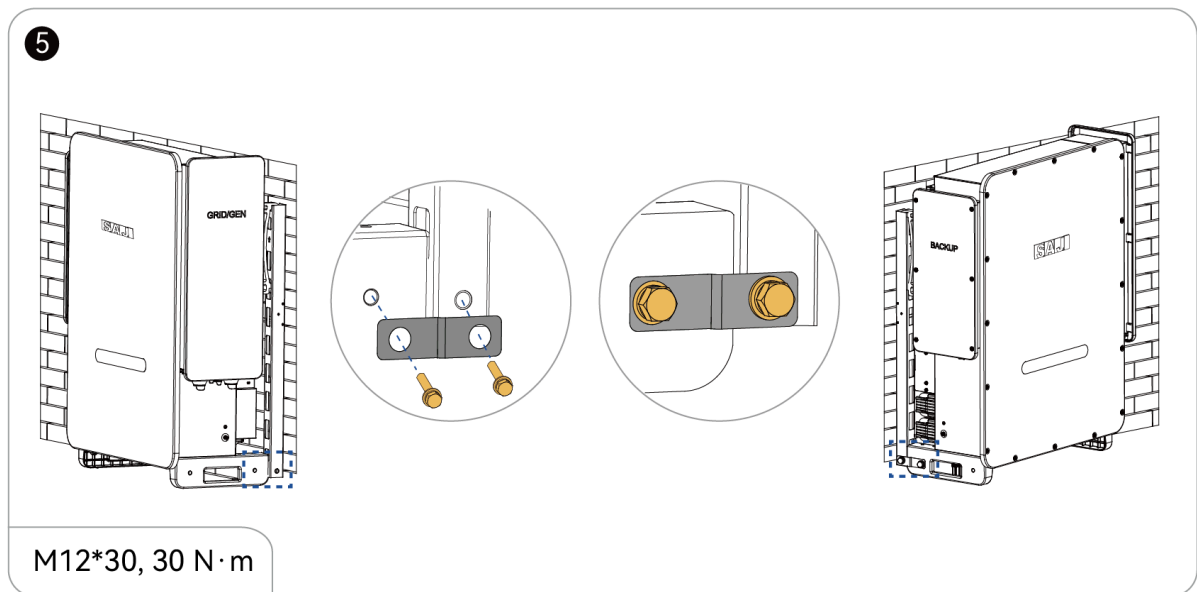

### 4.2.2. Mount the inverter on external frame

Follow this procedure to mount the inverter on an external frame.

**CAUTION**

Make sure that the frame can bear the weight of the inverter and the accessories.

**Procedure**

1. Select one of the four mounting options for securing the bracket to the frame.

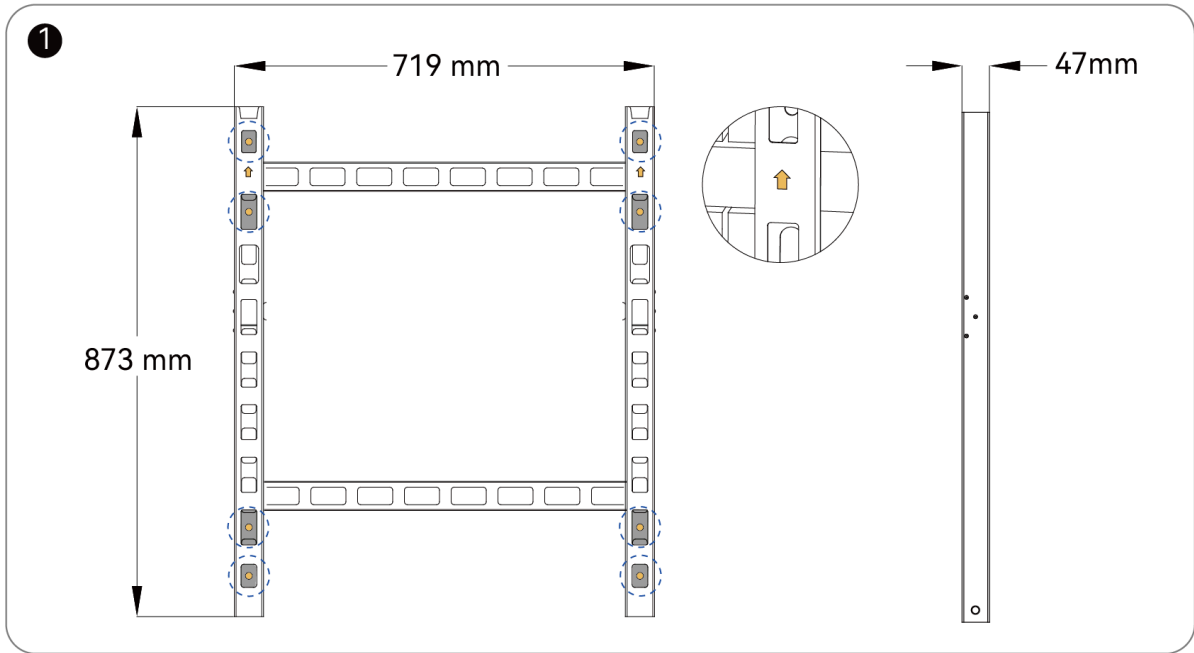
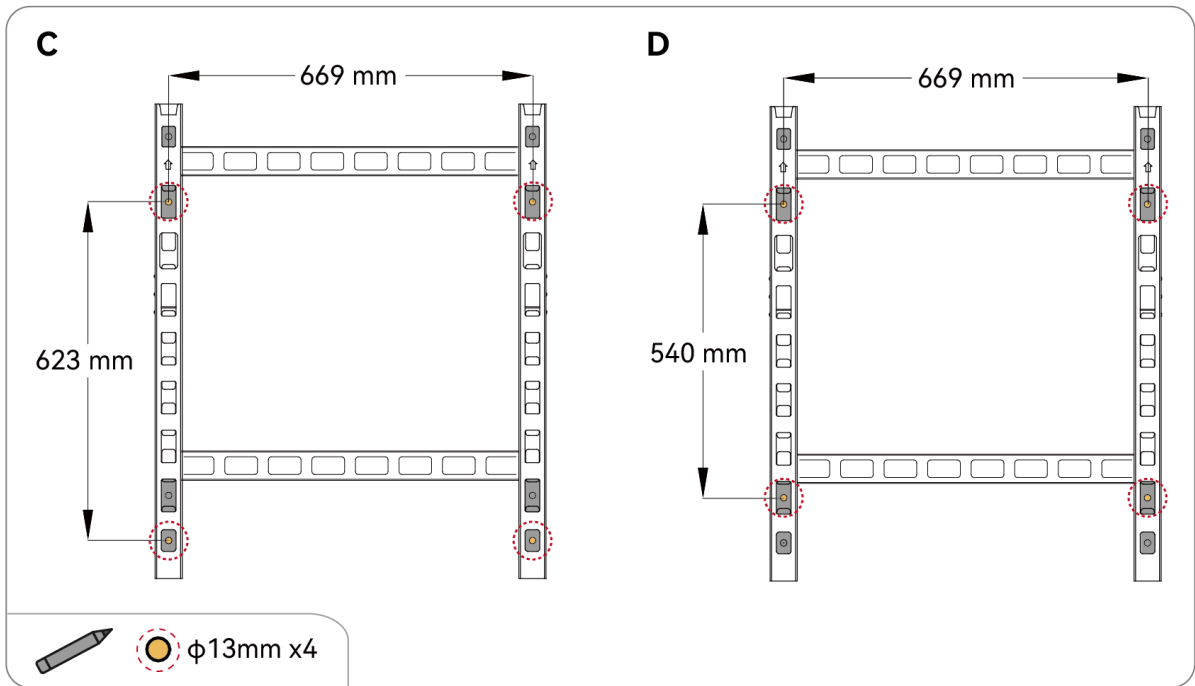
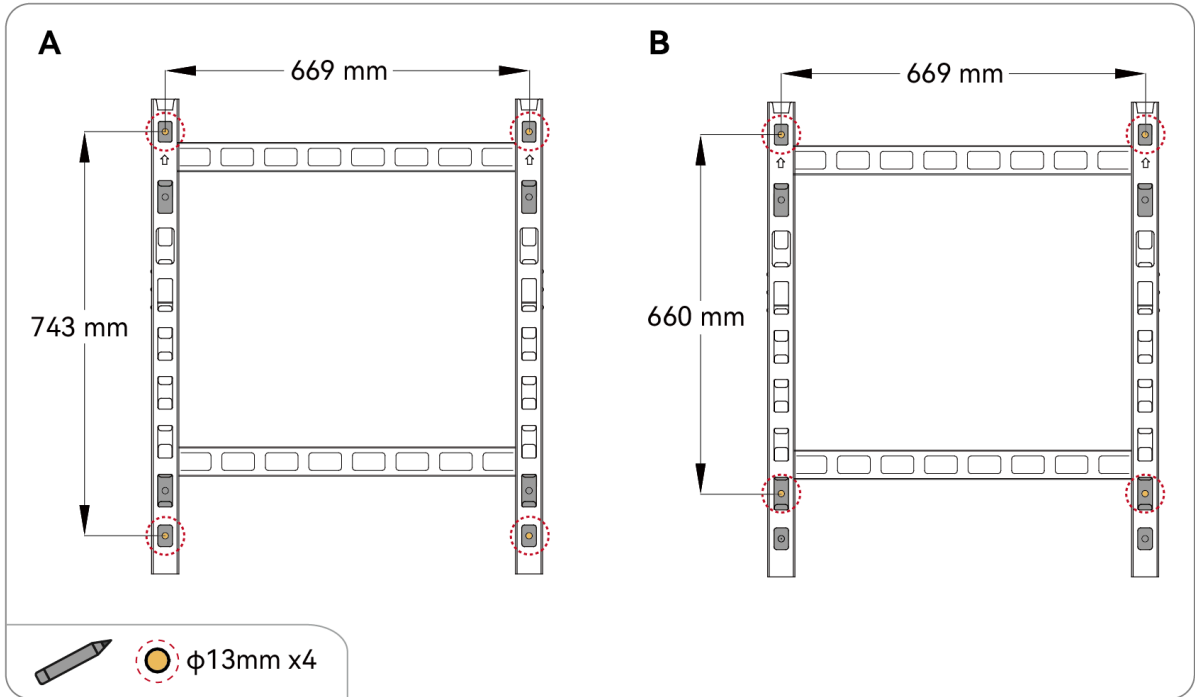

Figure 4.4. Mounting bracket size

**Mounting options:**

**Note: Recommended: Option A.**



2. Adjust the frame height accordingly.

**Example:**

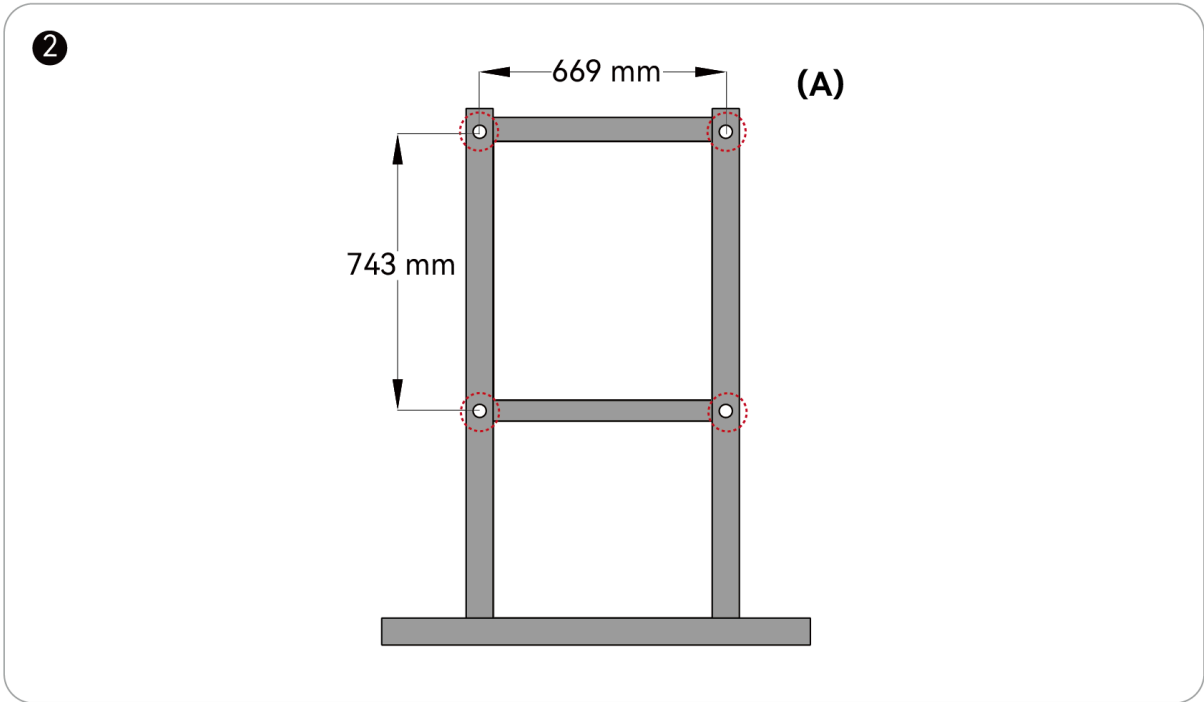
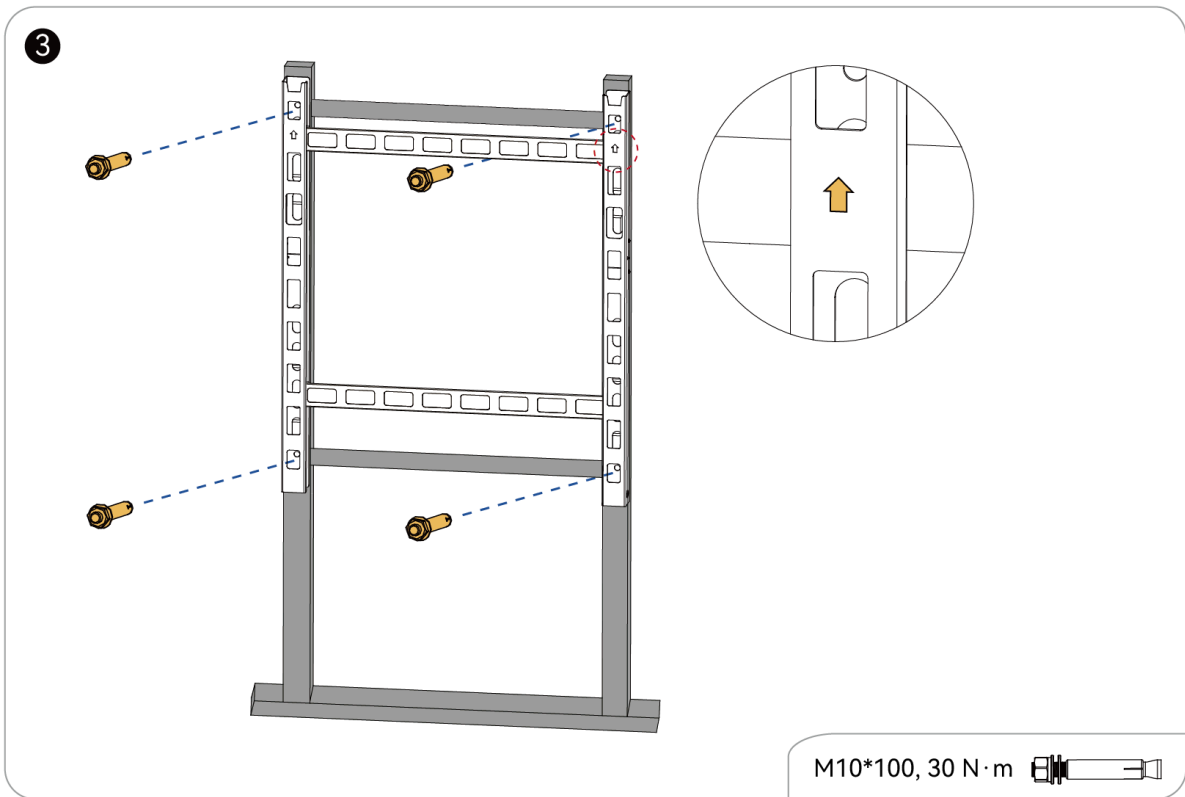

Figure 4.5. Frame height for mounting option A

3. Secure the mounting bracket to the frame with four screws.



4. Mount the inverter onto the bracket.

**Note:** Make sure that the inverter bottom is firmly placed against the bracket.

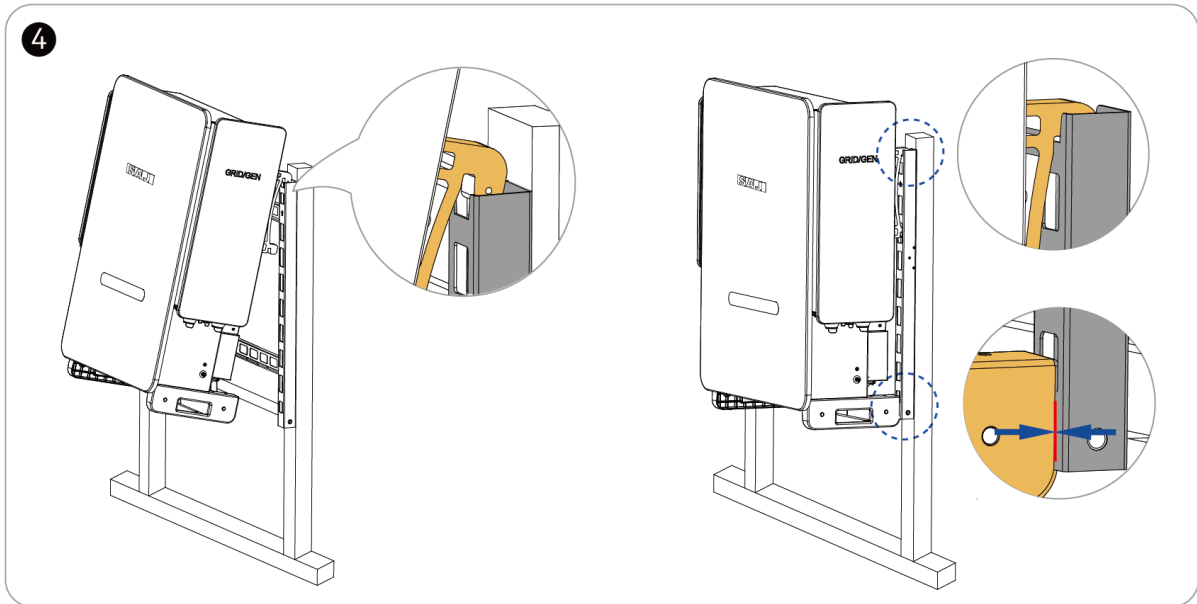

5. Install the metal plate to secure the inverter to the bracket.

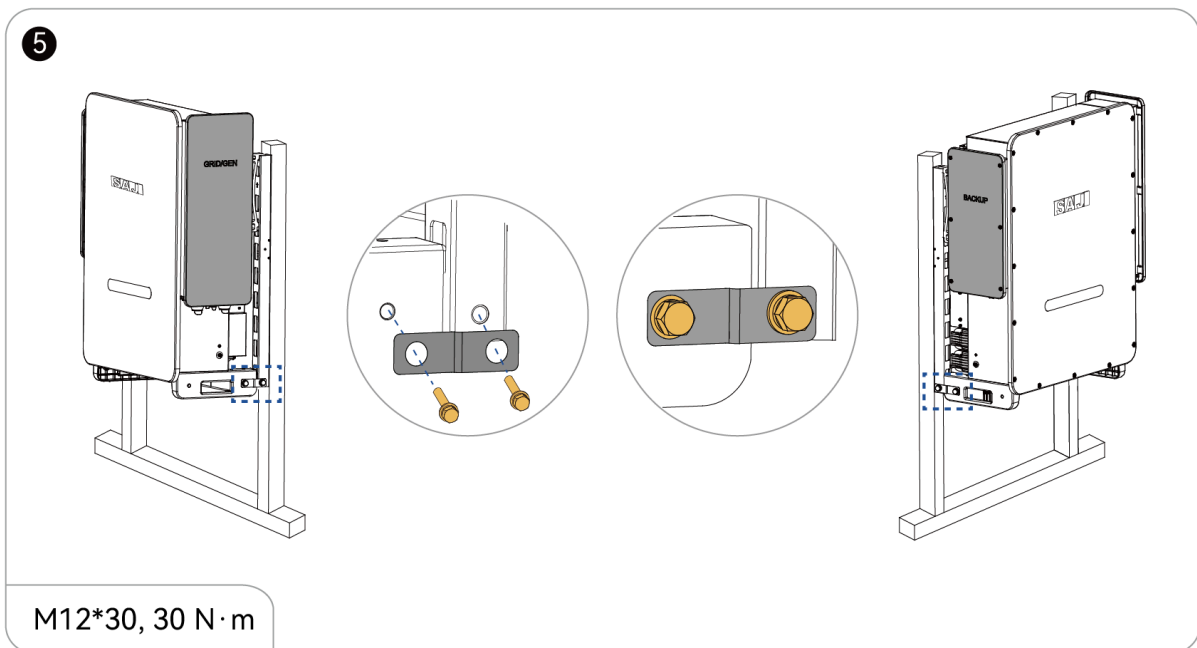

## 5. Electrical connection

### 5.1. Electrical connection safety

Electrical connection must only be operated by professional technicians. Before the operation, the technicians must wear necessary personal protective equipment (PPE) including insulating gloves, insulating shoes, and a safety helmet.



#### DANGER

**Danger to life due to potential fire or electricity shock.**

- Do not install the cabinet near any inflammable or explosive items.
- When it is powered on, the equipment should comply with national rules and regulations.



#### WARNING

Any improper operation during cable connection can cause device damage or personal injury.

#### 5.1.1. Wiring guidelines

- The selection, installation, and routing of cables must comply with local laws, regulations, and standards.
- During the placement of power cables, avoid coiling or twisting. If a power cable is found to be too short, replace it entirely; do not create splices or weld joints within the cable.
- Ensure that all cables are firmly connected, have good insulation, and are appropriately sized for their application.
- Cable trays and pass-through holes should not have sharp edges. Use protective measures at conduit entrances or pass-through holes to prevent damage to cables from sharp edges or burrs.
- Group similar types of cables together and secure them neatly, ensuring they lie flat and straight without damage to the outer jacket. Different types of cables should be laid separately to avoid entanglement or crossing.
- For buried cables, use cable supports and clamps to securely fix them in place. Ensure that backfilled soil around underground cables is compacted to prevent deformation or damage during the backfilling process.
- When external conditions like installation methods or ambient temperatures change, verify the cable selection according to local regulations to ensure parameters like current-carrying capacity.
- To prevent insulation aging or damage due to high temperatures, maintain a minimum distance of 30 mm between cables and heat-generating components or heat source peripheries.

#### 5.1.2. Ground protection

- Follow the grounding guidelines below for the equipment which is critical to ensure electrical safety and compliance with local standards:
- The impedance of the equipment's grounding system must meet the requirements specified by local electrical standards.
- The equipment must be permanently connected to a protective ground. Before operating the equipment, always check the electrical connections to ensure that the equipment is reliably grounded.
- It is strictly prohibited to operate the equipment if the grounding conductor has not been installed.
- Do not damage or tamper with the grounding conductor in any way.

### 5.1.3. AC- and DC-side handling

- Before installing or removing power cables, turn off all switches on both the AC and DC sides to ensure that no electrical flows through the system during the operation.
- Prior to connecting the AC side cables, verify that the phase sequence of the three-phase cables matches the silk-screen markings on the cable connectors.
- If the equipment has multiple input and output paths, disconnect all inputs and outputs before proceeding. After ensuring all power sources are disconnected, wait for at least 5 minutes to allow any residual charge in capacitors or other components to dissipate. Only then should you perform any operations on the equipment.

### 5.1.4. Electrostatic Discharge (ESD) Protection



#### CAUTION

Contact with or improper handling of printed circuit boards or other electrostatic discharge sensitive components can lead to device damage.

- Avoid unnecessary contact with circuit boards.
- Adhere to ESD protection standards, such as wearing an anti-static wrist strap.

### 5.1.5. Earth fault alarm monitoring

This inverter is of transformer-less design and therefore does not provide galvanic isolation between the DC and AC sides. To comply with safety requirements, it incorporates earth fault alarm monitoring function in accordance with IEC 62109-2, clause 13.9. This function continuously checks the insulation resistance of the PV array to earth.

If an earth fault is detected due to damaged cables, moisture ingress or similar reasons, the inverter responds as follows:

- The LED light illuminates **red**.
- An error code **<31>** is displayed in the elekeeper App.



#### NOTICE

This inverter **must not be connected to functionally earthed PV arrays**, where either the positive or negative pole is permanently connected to earth. Such installations would be interpreted as a permanent earth fault, causing continuous false alarms and potentially damaging the inverter's internal circuitry.

## 5.2. Plan the cable connections

### 5.2.1. Single deployment

#### Single deployment

The following figure shows the system connections of single deployment with both on-grid and backup connections.

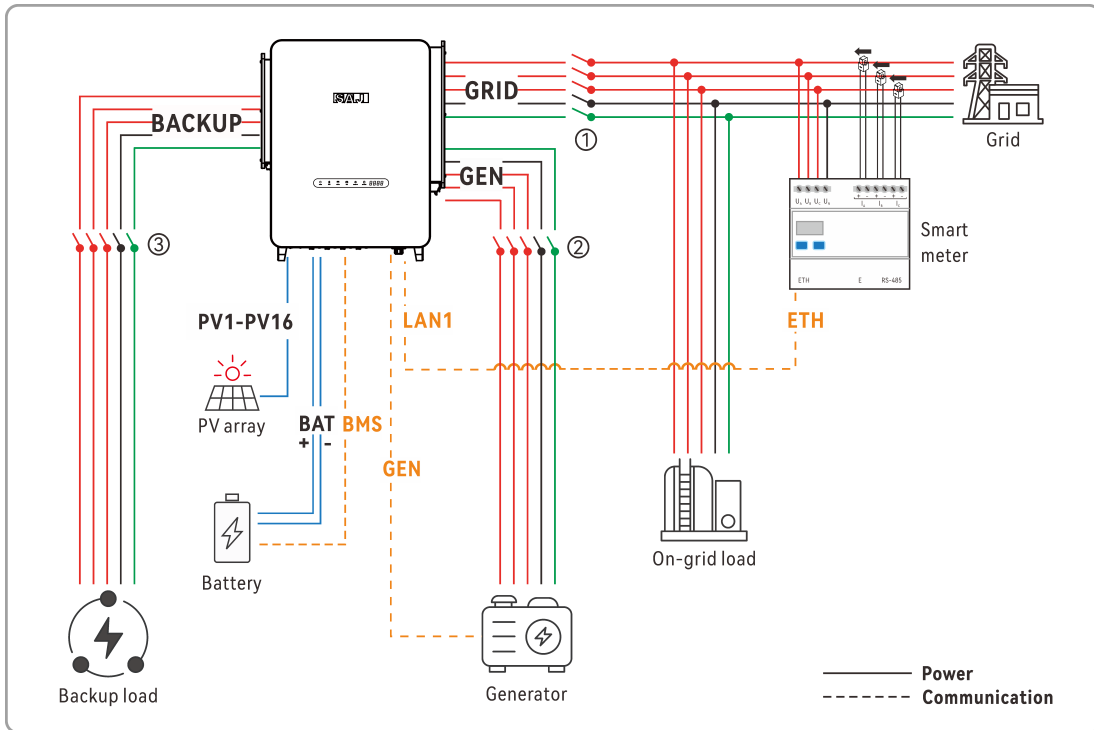

Figure 5.1. Single deployment with on-grid and backup connections

Prepare the AC circuit breakers according to the recommended specifications below:

Product model	Grid AC breaker ① - with BACKUP connection	Grid AC breaker ① - without BACKUP connection	Generator AC breaker ②	Backup AC breaker ③
CH3-(75K-125K)-(T6,T8)-EU	300 A	250 A	250 A	250 A
CH3-(75K-125K)-(T6,T8)-G-EU	-	250 A	-	-

Table 5.1. Recommended AC breaker specifications

### 5.2.2. Parallel deployment

The CH3 series inverters support parallel deployment for different application scenarios.

In a parallel system, one inverter must be designated as the primary inverter to orchestrate external communications and internal system coordination. For example, the DO connection to the diesel generator must be wired directly to the primary inverter.

#### With on-grid connections only - 20 inverters at maximum

The following figure shows the system connections of parallel deployment with on-grid connections only. In this deployment, a maximum of 20 inverters can be installed.

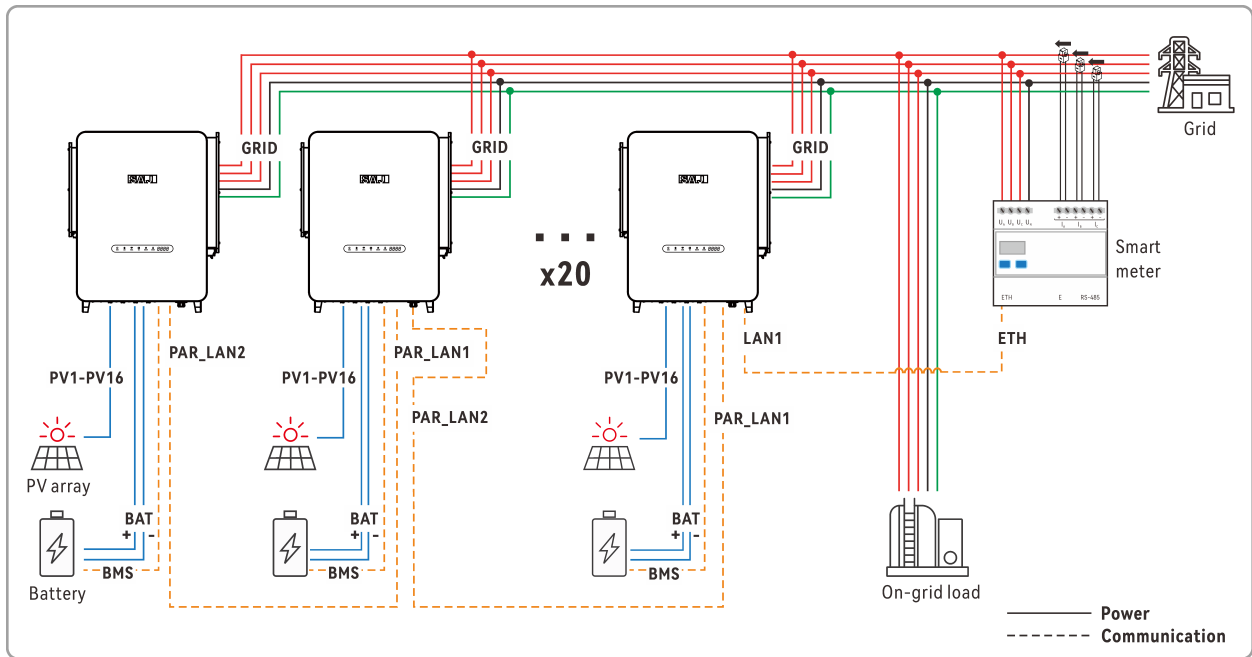

Figure 5.2. Parallel deployment with on-grid connections only - 20 inverters at maximum

**With on-grid and backup connections - 10 inverters at maximum**

The following figure shows the system connections of parallel deployment with both on-grid and backup connections. In this deployment, a maximum of 10 inverters can be installed.

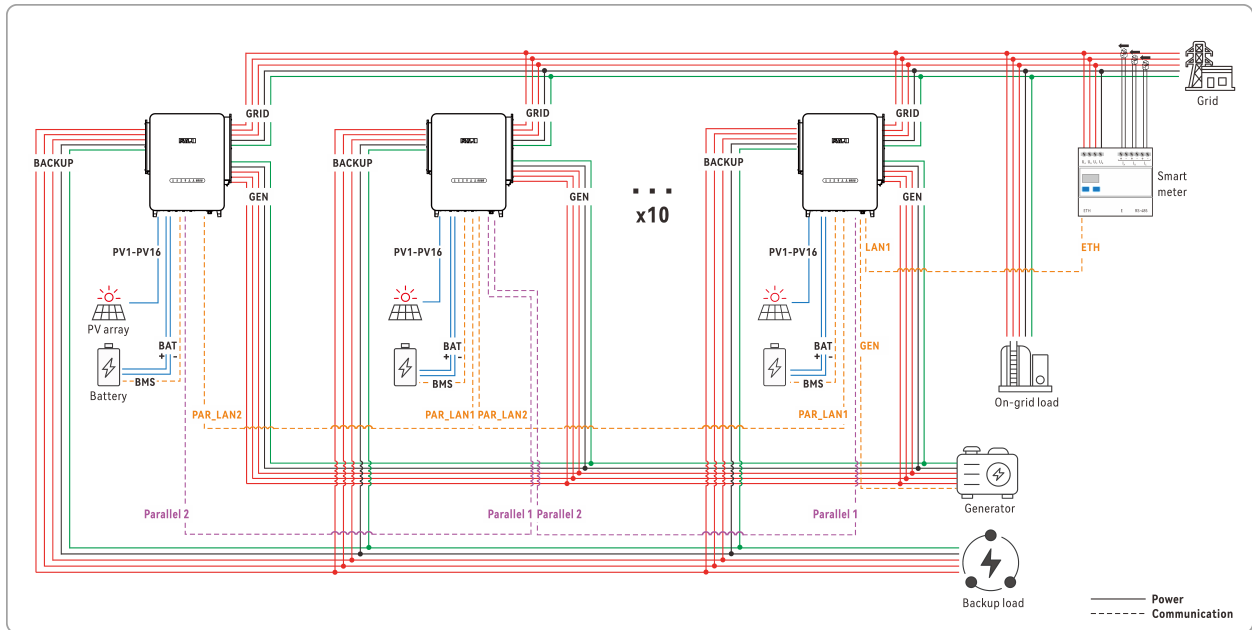

Figure 5.3. Parallel deployment with on-grid and backup connections - 10 inverters at maximum

**5.2.3. Smart meter connection solutions**

CH3 series inverters support the following smart meter connection solutions. Plan the meter connection according to actual customer requirements.

For customized requirements and solutions, contact SAJ product support.

**One meter for single deployment**

Install the grid meter between the grid main breaker and the loads. The directional arrow on the CT must point towards the on-grid loads.

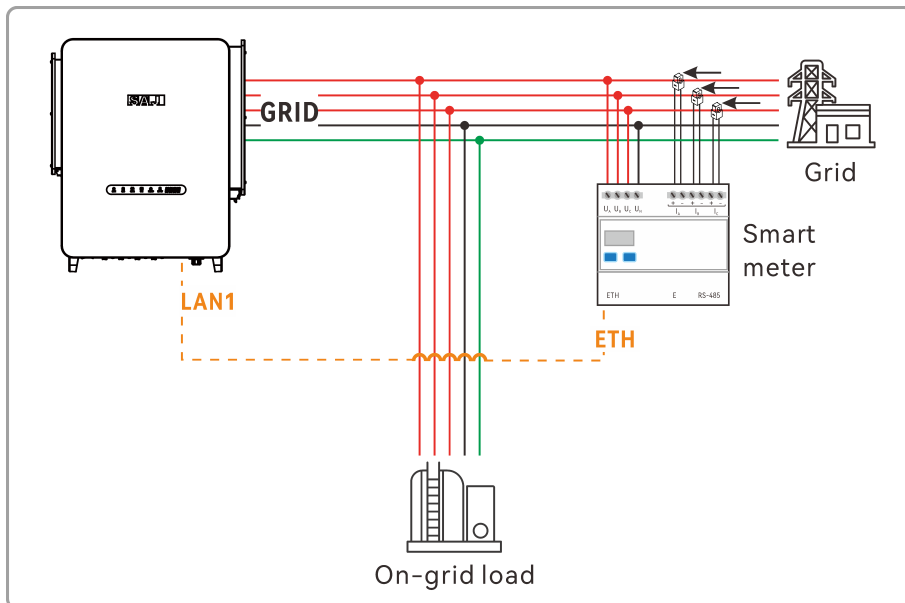

**Two meters for single deployment with third-part inverter**

The second smart meter can be installed for the third-party inverter and reports data to CH3 through LAN2 connection.

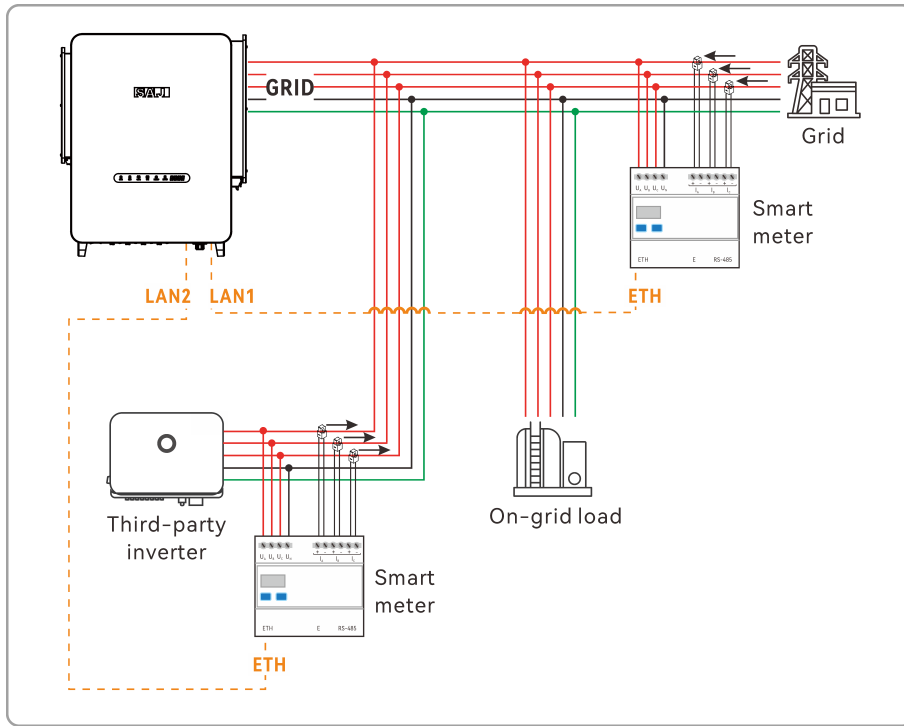

**Two meters for parallel deployment with third-part inverter**

The second smart meter can be installed for the third-party inverter and reports data to CH3 through **LAN1** connection.

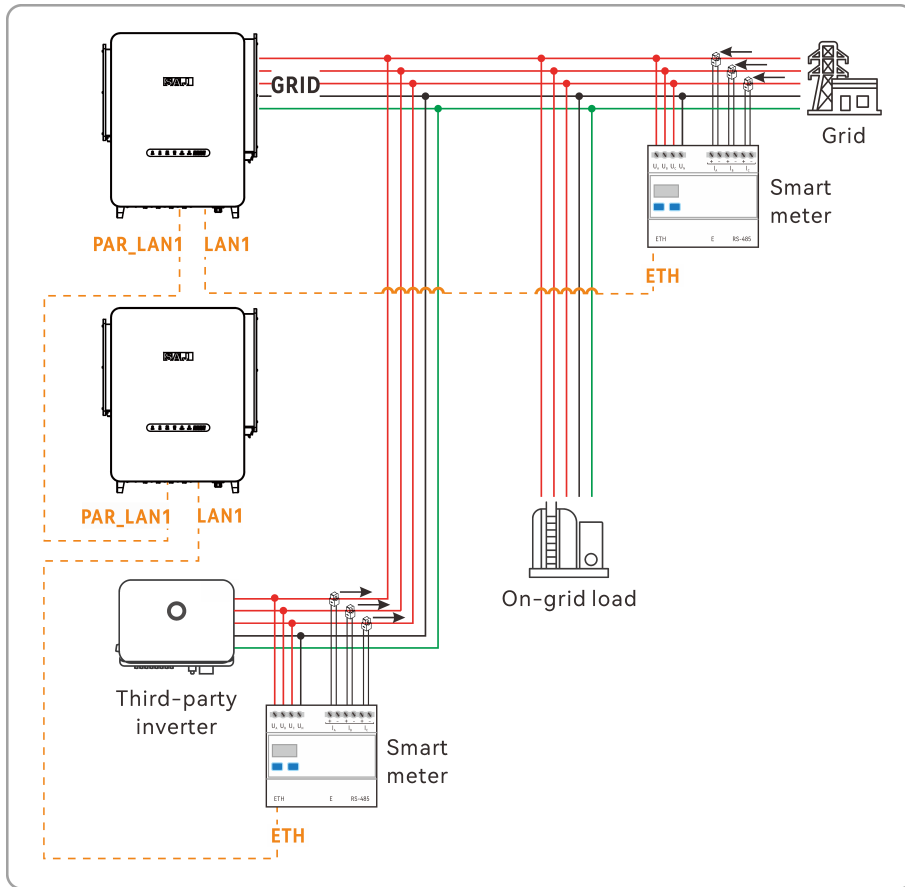

### Two meters for parallel deployment through a switch

The second smart meter can be installed for the third-party inverter and reports data to CH3 through LAN connection over an external switch. The inverter also connects to the switch through **LAN1** connection.

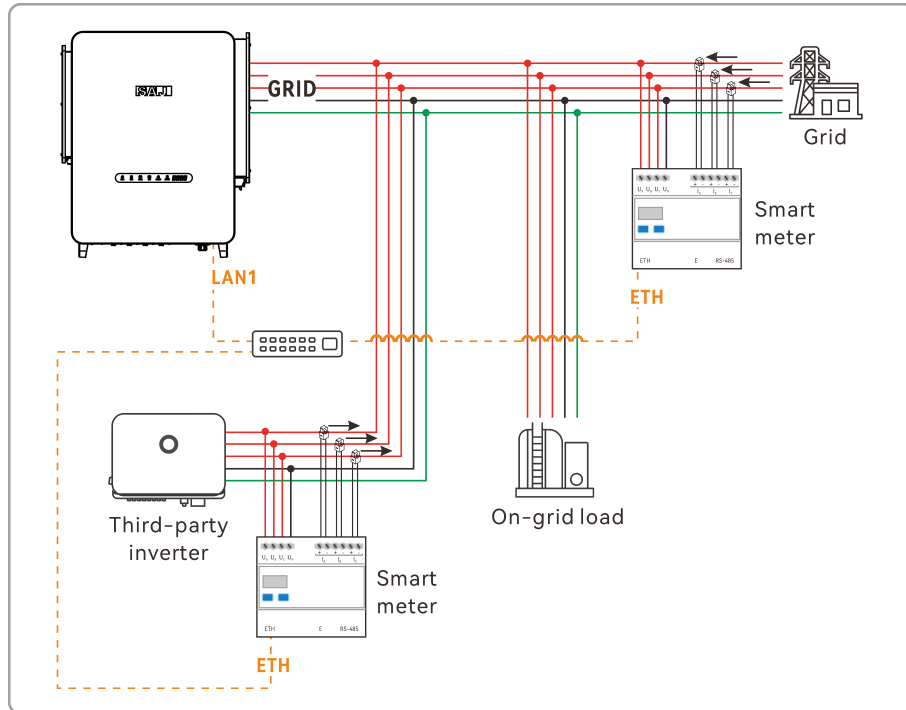

### 5.3. Prepare electrical cables

Prepare the items listed in this section before installation.

### Grounding cable

Cable type	Conductor cross-sectional area (mm <sup>2</sup> )		Connecting terminal
	Range	Recommended	
Outdoor multi-core copper wire cable	35-90	35	RNB38-8 OT terminal in the package

Table 5.2. Grounding cable

### PV power cables

Cable type	Conductor cross-sectional area (mm <sup>2</sup> )	Maximum current (A)	Outer diameter range (mm)
Outdoor single-conductor PV cable (≥1500V)	5.26-6.0	35	4.0-7.0

Table 5.3. PV power cable

### Communication cables

Connector type	Cable type	Conductor cross-sectional area (mm <sup>2</sup> )	Connecting terminal
RJ45 connection	CAT 5E outdoor shielded network cable with internal resistance ≤1.50 Ω/10m	-	RJ45 connector in the package
2/3/6-pin connections	Multi-core high-temperature outdoor communication cable	0.2-3.3	2/3/6-pin connectors installed on the communication terminal block of the inverter.

Table 5.4. Communication cables

### AC power cables - CH3-(75K-125K)-(T6,T8)-EU

**Cable type:** Outdoor multi-core high-temperature cable (≥400V)

The following table specifies the required AC cable gauges for the **Grid** connection when the backup output is active. Under this configuration, the Grid is capable of powering the backup loads and simultaneously charging the battery.

Connection	Model	Max. current (A)	Cross-sectional area (mm <sup>2</sup> )	Recommended (mm <sup>2</sup> )	Outer diameter range (mm)
Grid	CH3-75K-T6-EU	200	50-95	70	25-70
	CH3-80K-T6-EU	200	50-95	70	
	CH3-99.9K-T8-EU CH3-100K-T8-EU	250	70-120	95	
	CH3-110K-T8-EU	250	70-120	95	
	CH3-125K-T8-EU	250	70-120	95	

Table 5.5. Grid connection - with active backup connection

The following table specifies the required AC cable gauges for the **Grid** connection when the backup output is disabled.

Connection	Model	Max. current (A)	Cross-sectional area (mm <sup>2</sup> )	Recommended (mm <sup>2</sup> )	Outer diameter range (mm)
Grid	CH3-75K-T6-EU	114	25	25	25-70
	CH3-80K-T6-EU	122	35	35	

Connection	Model	Max. current (A)	Cross-sectional area (mm <sup>2</sup> )	Recommended (mm <sup>2</sup> )	Outer diameter range (mm)
	CH3-99.9K-T8-EU CH3-100K-T8-EU	152	35-70	50	
	CH3-110K-T8-EU	167	35-70	50	
	CH3-125K-T8-EU	190	50-95	70	

Table 5.6. Grid connection - with Backup connection disabled

The following table specifies the required AC cable gauges for the **Generator** connection.

Connection	Model	Max. current (A)	Cross-sectional area (mm <sup>2</sup> )	Recommended (mm <sup>2</sup> )	Outer diameter range (mm)
Generator	CH3-75K-T6-EU	114	25	25	25-70
	CH3-80K-T6-EU	122	35	35	
	CH3-99.9K-T8-EU CH3-100K-T8-EU	152	35-70	50	
	CH3-110K-T8-EU	167	35-70	50	
	CH3-125K-T8-EU	190	50-95	70	

Table 5.7. Generator connection

The following table specifies the required AC cable gauges for the **Backup** connection in single deployment.

Connection	Model	Max. current (A)	Cross-sectional area (mm <sup>2</sup> )	Recommended (mm <sup>2</sup> )	Outer diameter range (mm)
Backup (single deployment)	CH3-75K-T6-EU	114	25	25	25-54
	CH3-80K-T6-EU	122	35	35	
	CH3-99.9K-T8-EU CH3-100K-T8-EU	152	35-70	50	
	CH3-110K-T8-EU	167	35-70	50	
	CH3-125K-T8-EU	190	50-95	70	

Table 5.8. Backup connection in single deployment

The following table specifies the required AC cable gauges for the **Backup** connections in parallel deployment.

Connection	Model	Max. current (A)	Cross-sectional area (mm <sup>2</sup> )	Recommended (mm <sup>2</sup> )	Outer diameter range (mm)
Backup (Parallel deployment)	CH3-75K-T6-EU	228	50-95	70	25-54
	CH3-80K-T6-EU	243	70-120	95	
	CH3-99.9K-T8-EU CH3-100K-T8-EU	304	95-150	120	
	CH3-110K-T8-EU	334	120-185	150	
	CH3-125K-T8-EU	380	150-240	150	

Table 5.9. Backup connections in parallel deployment

### 5.4. Connect the grounding cable

 **WARNING**

**Connect the grounding cable before other electrical connections.**

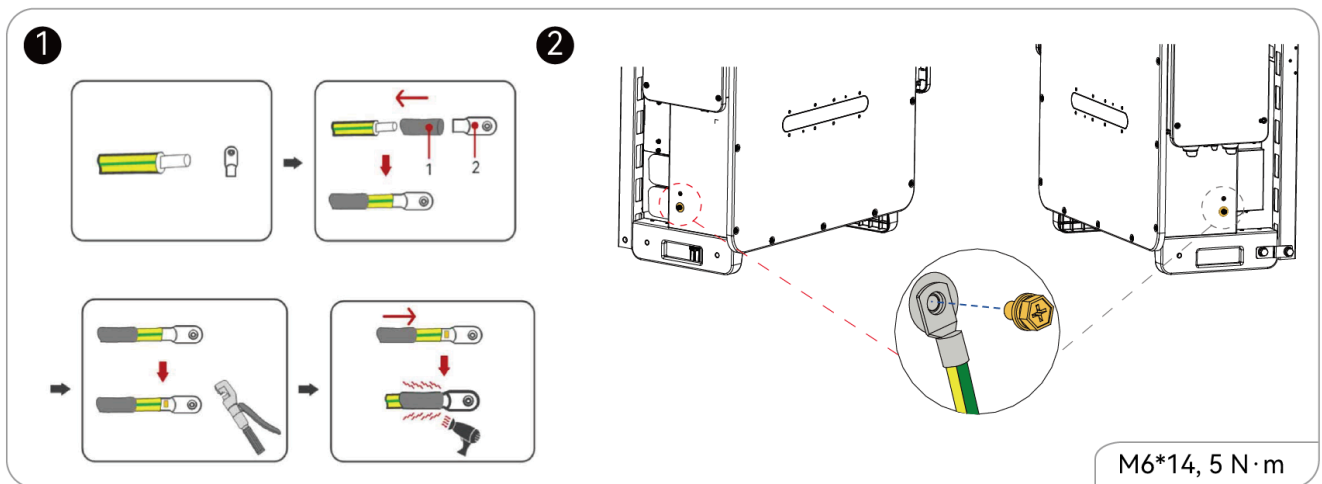

**Procedure**

1. Assemble the cable with the RNBS38-8 OT/DT terminal.
2. Remove the screw from one of the grounding terminal, insert the screw through the OT/DT terminal, and tighten the cable with the screw.  
Two grounding connection points are provided for cable connection convenience. Select one of the ports for connection.
3. Connect the other cable end to the external earthing bar.

### 5.5. Connect the AC power cables

Connect the AC power cables according to the following diagram.

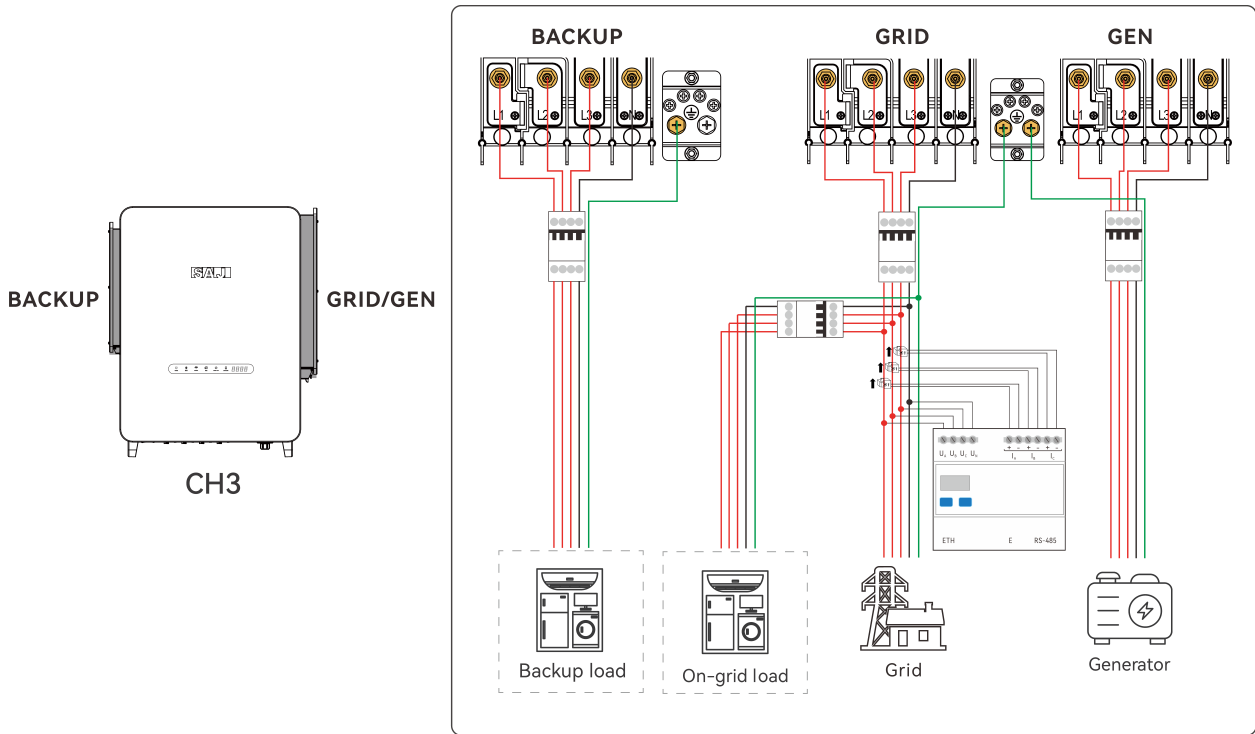
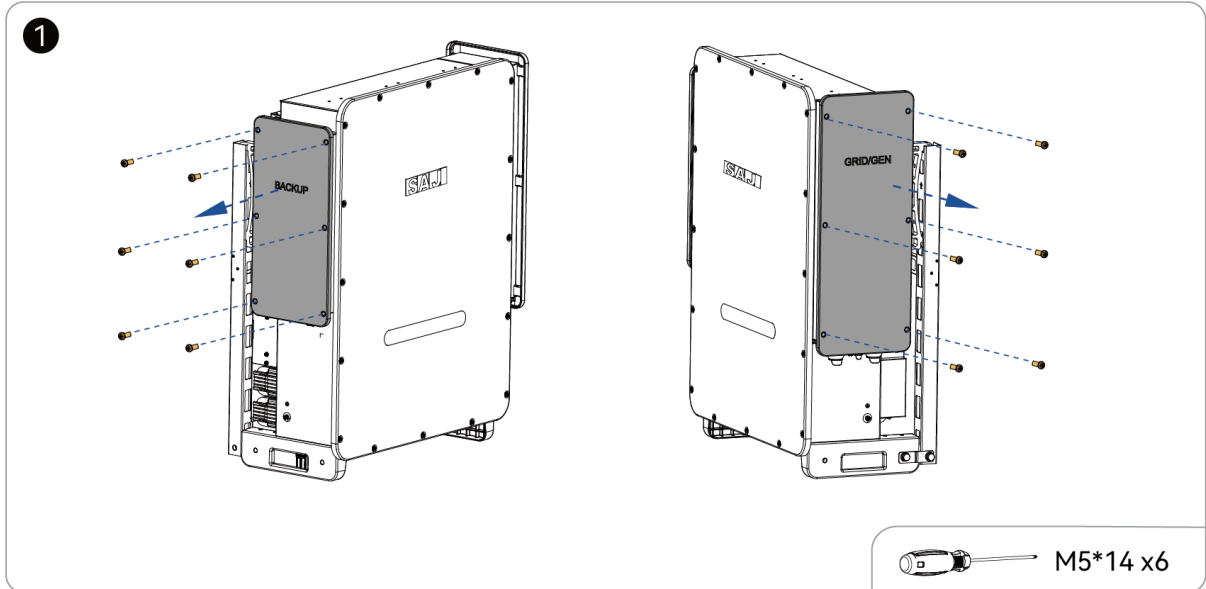

Figure 5.4. AC power cable connections

**Procedure**

1. Remove the cable covers from the inverter.



2. Assemble the **GEN**, **GRID**, and **BACKUP** cables with the OT terminals.

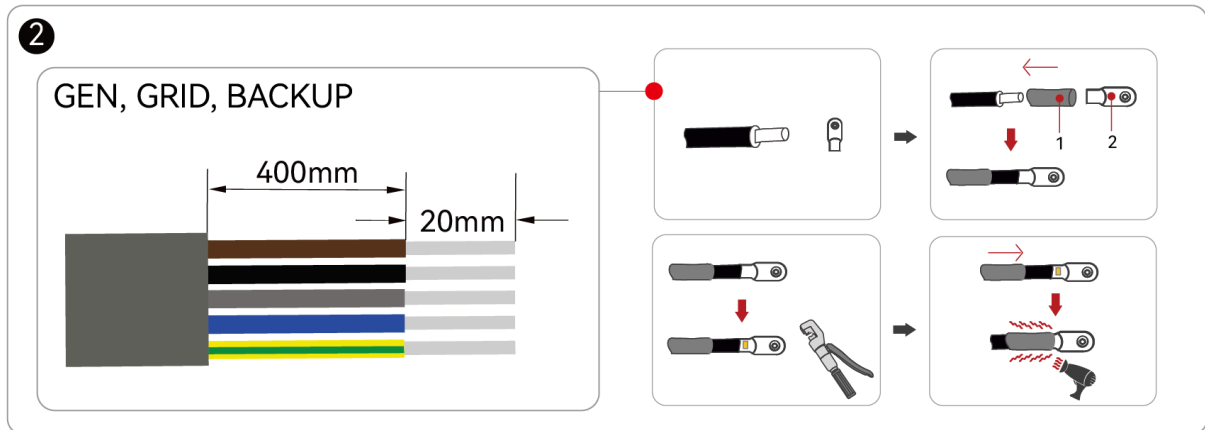

3. Select the cable entry according to the actual cable diameter. Peel off the plastic seal from the corresponding entry.

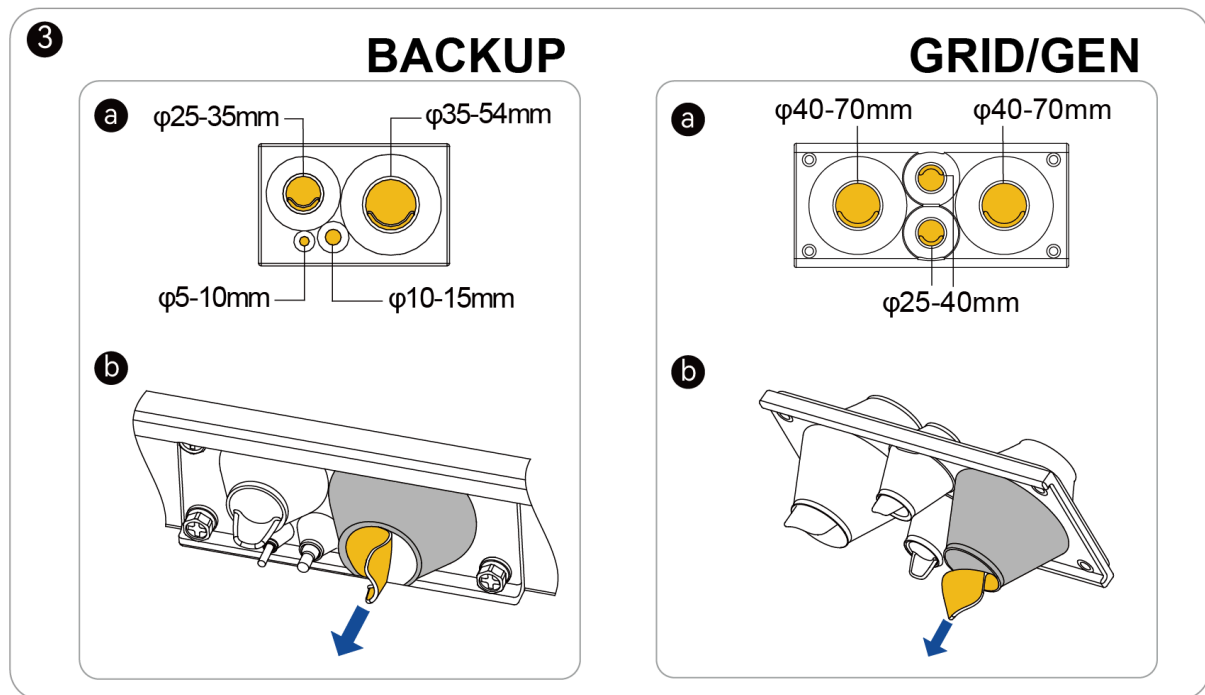

4. Pass the **GRID** cables through the bottom of the inverter and secure the cables to the **L1, L2, L3, N,** and **PE** terminals.

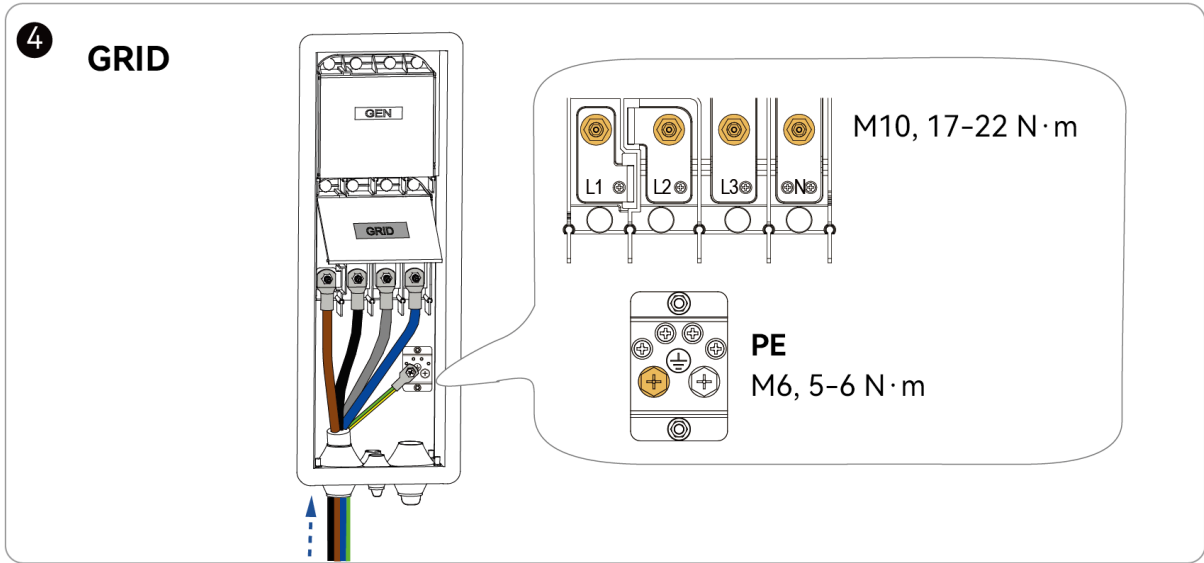

5. Pass the **GEN** cables through the bottom of the inverter and secure the cables to the **L1, L2, L3, N,** and **PE** terminals.

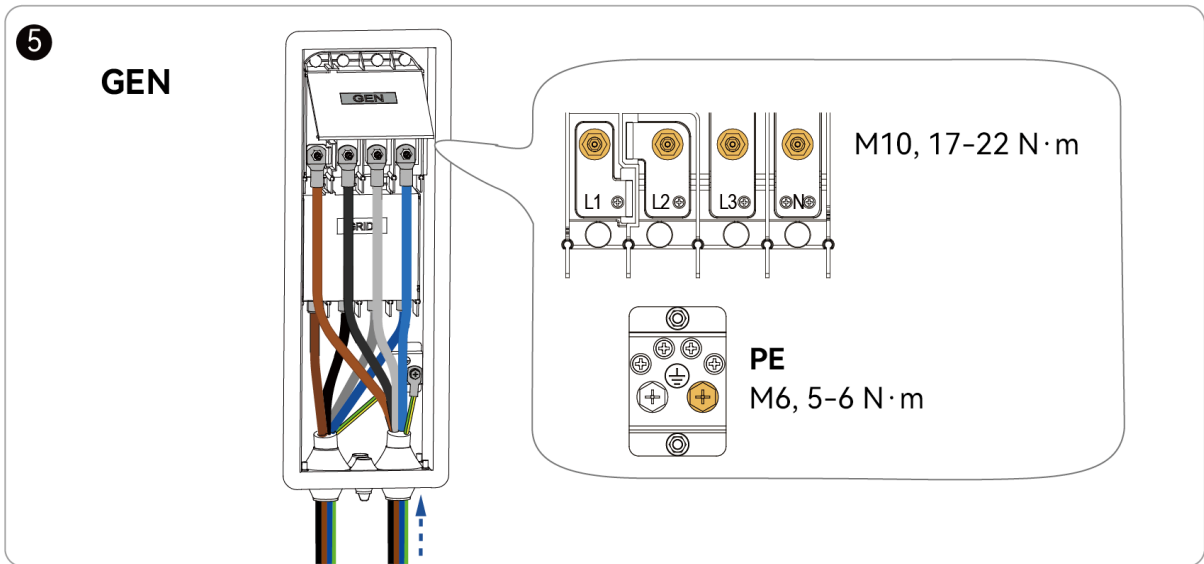

6. Pass the **BACKUP** cables through the bottom of the inverter and secure the cables to the **L1, L2, L3, N,** and **PE** terminals.

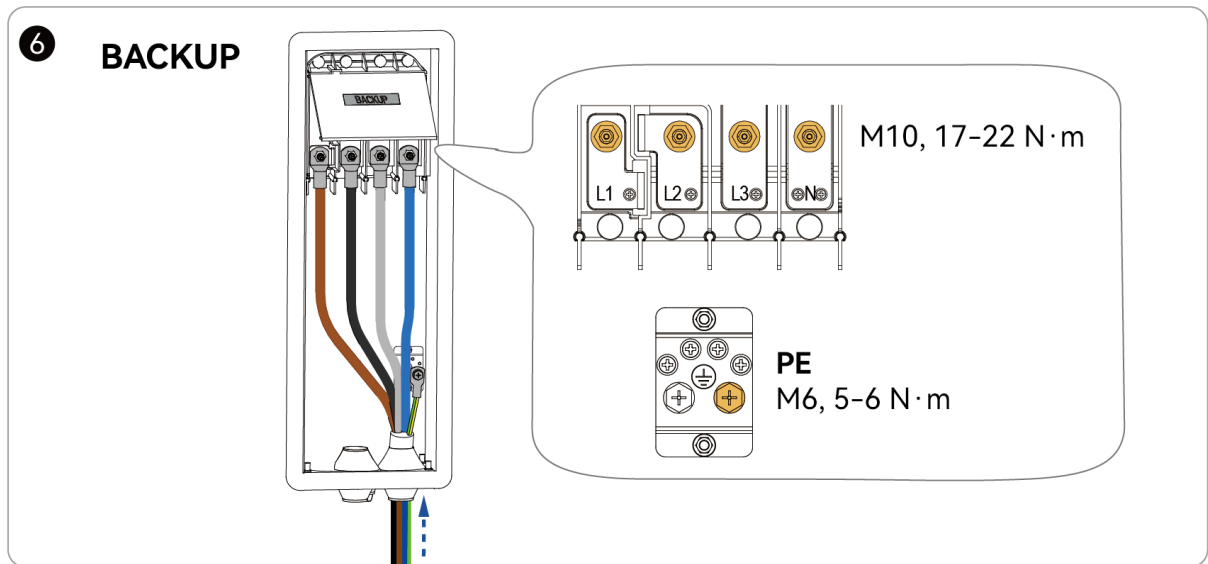

7. Install and secure the cable covers on the **BACKUP** and **GRID/GEN** sides.

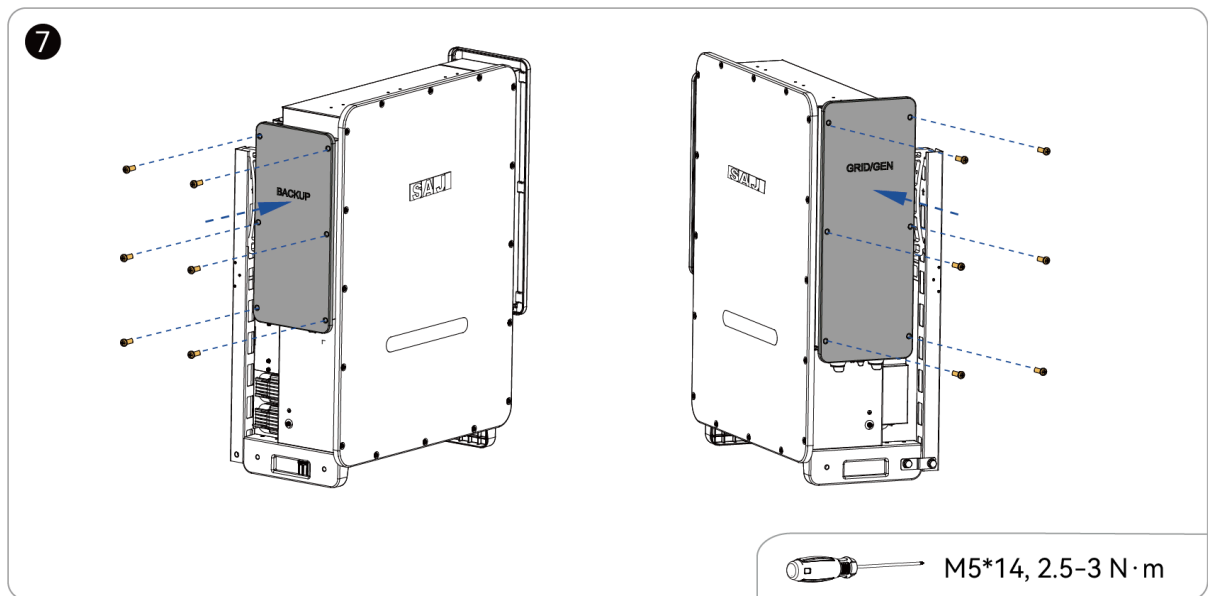

## 5.6. Connect the smart meters

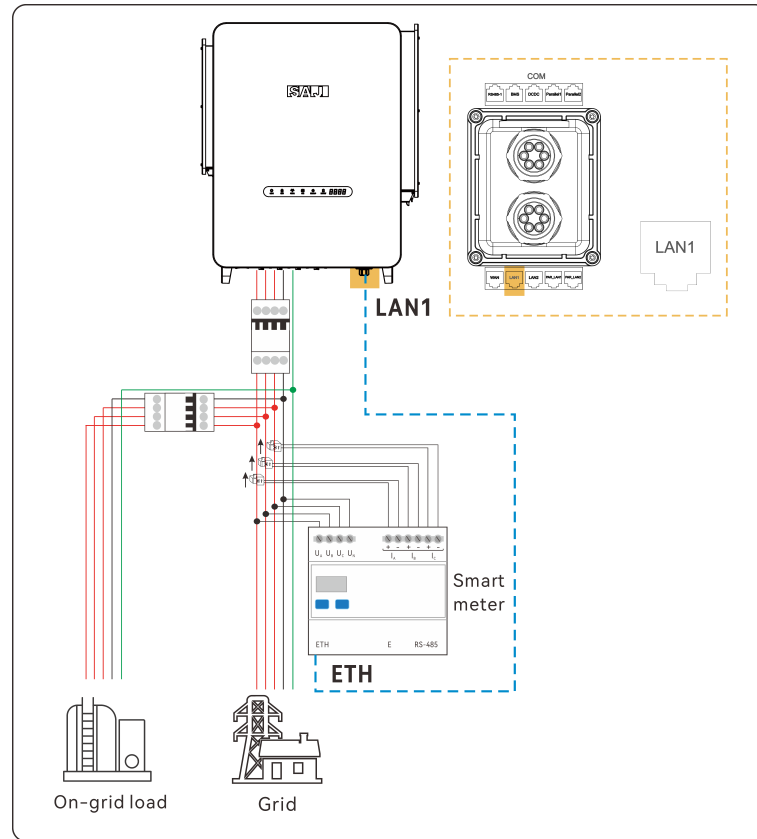

**Procedure**

1. Connect the meter power cables.
2. Install the CTs pointing to the on-grid load.
3. Connect the standard network cable between the inverter **LAN1** port and the meter **ETH** port.

**5.7. Connect the communication cables**

Follow this common procedure to connect the 2-pin, 3-pin, 6-pin, and RJ45 communication cables for the corresponding functions.

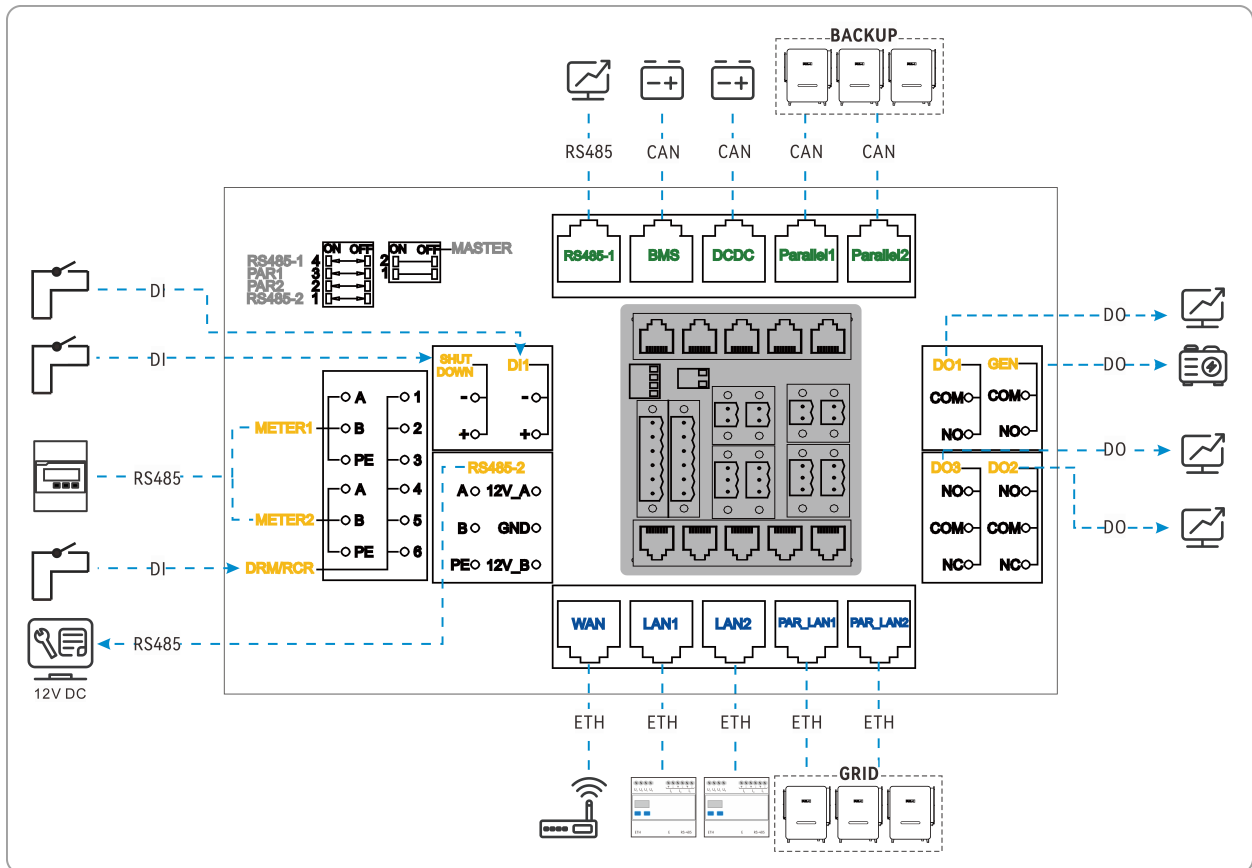
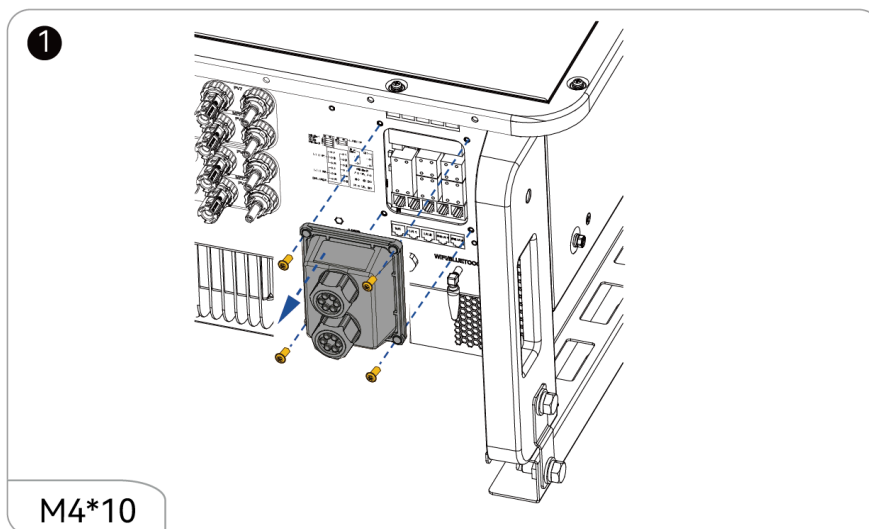

Figure 5.5. CH3 communication connection overview

**Procedure**

1. Remove the cable cover at the bottom of the inverter.



2. Assemble the pin connectors and RJ45 connectors according to the actual requirement. Pass the cables through the cable gland on the cover.

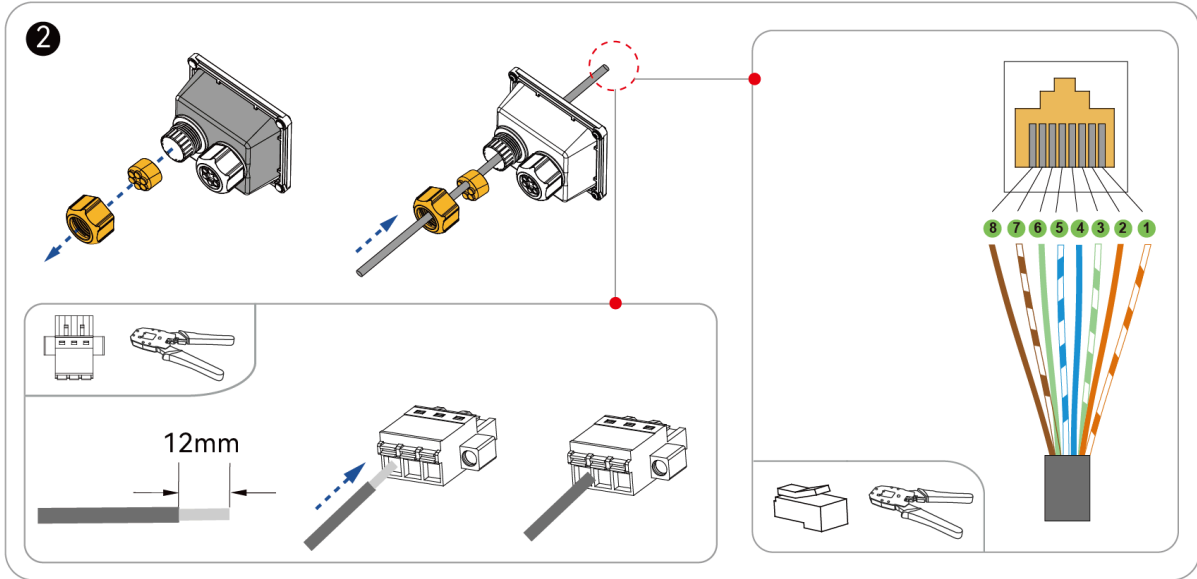

3. Connect the communication cables to the corresponding ports.

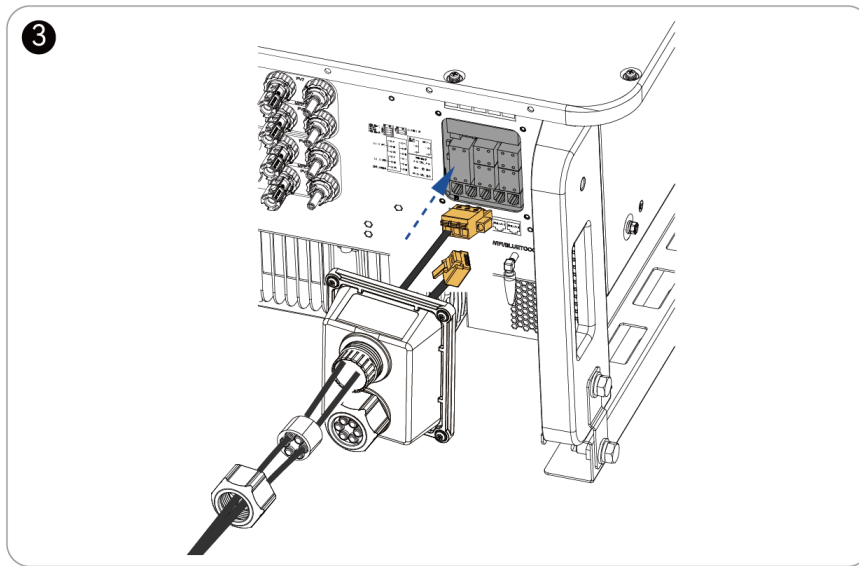

4. Install the cable cover to the inverter and tighten the cable gland.

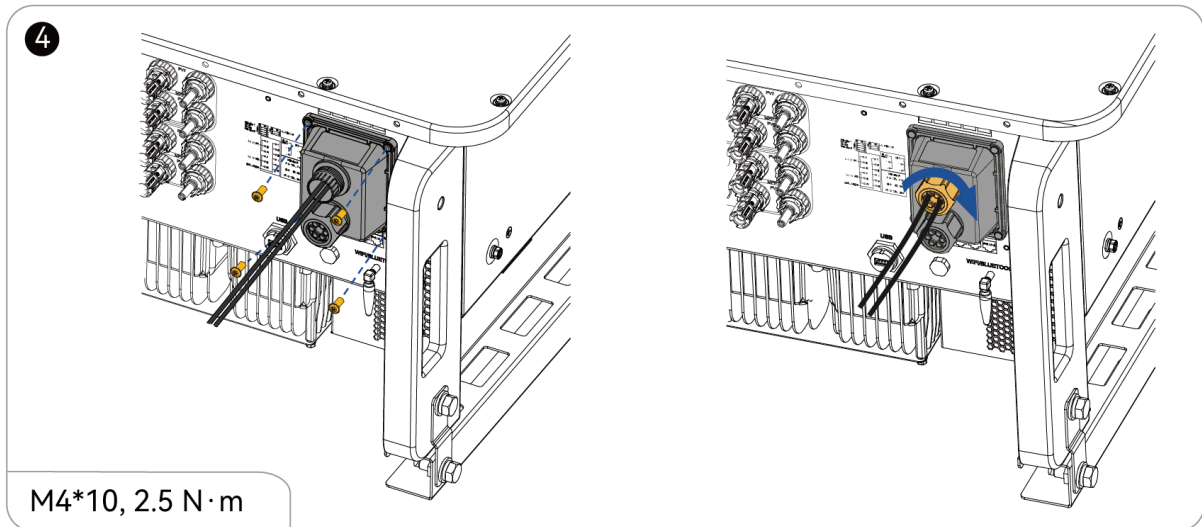

### 5.7.1. Connect the emergency shutdown device

The 2-pin **SHUT DOWN** port can connect with an external switch to stop the inverter immediately in emergent situations.

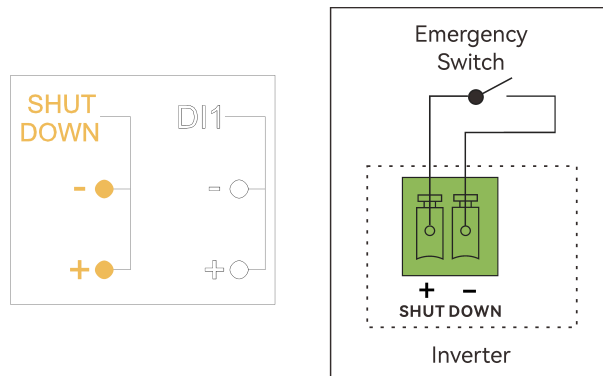

### 5.7.2. Connect the RCR device

According to the local regulations, a ripple control receiver (RCR) device is required to control the maximum output power that is exported to the grid.

When the RCR device connecting to the DI port is closed, the device signals the inverter to export power to the grid at the corresponding level that is configured for the **RCR Power Settings** on the elekeeper App. Each port corresponds to the following settings on the App:

- **DI1:** LEVEL1
- **DI2:** LEVEL2
- **DI3:** LEVEL3
- **DI4:** LEVEL4

The rated power control limit of K1 to K4 devices increases. Connect the devices accordingly to the 6-pin **DRM/RCR** ports **DI1** to **DI4**.

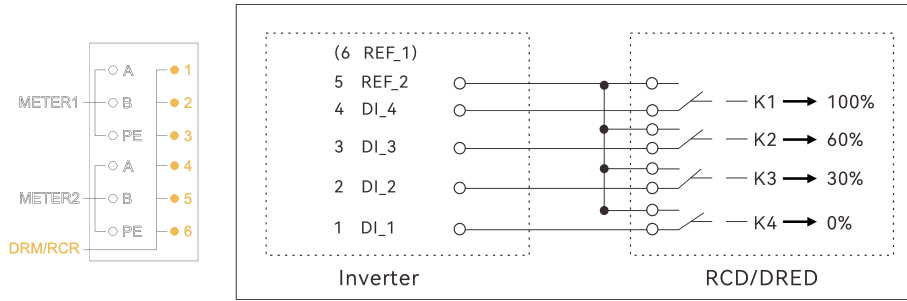

### 5.7.3. Connect the DRED device (Australia and New Zealand)

According to the local regulations in Australia and New Zealand, a DRED device is required for demand response modes (DRM) control. Connect the DRED device to the following 6-pin **DRM/RCR** port:

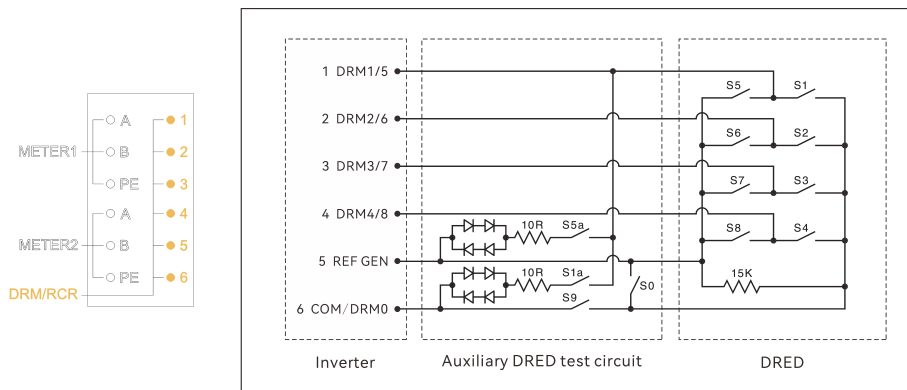

### 5.7.4. Connect the generator communication

Connect the generator to the 2-pin **GEN** port to control the start and stop of the generator:

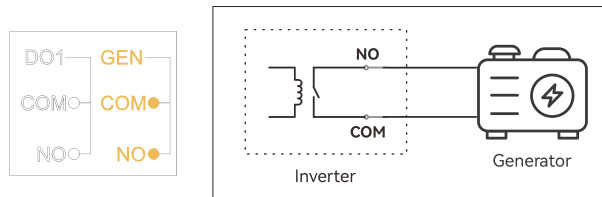

### 5.7.5. Connect the parallel deployment communication

For CH3 parallel deployment, connect the communication cables as illustrated in section [5.2.2. Parallel deployment \(on page 33\)](#).

- In on-grid only deployment, connect the standard network cables between the **PAR\_LAN1** and **PAR\_LAN2** ports on the inverters.
- When the backup connections are enabled, also connect the standard network cables between the **Parallel1** and **Parallel2** ports on the inverters.

### 5.7.6. Turn on DIP switches

The dual inline package (DIP) switches are provided to control the activation of 120 Ω terminal resistors to ensure the communication stability of the corresponding communication functions.

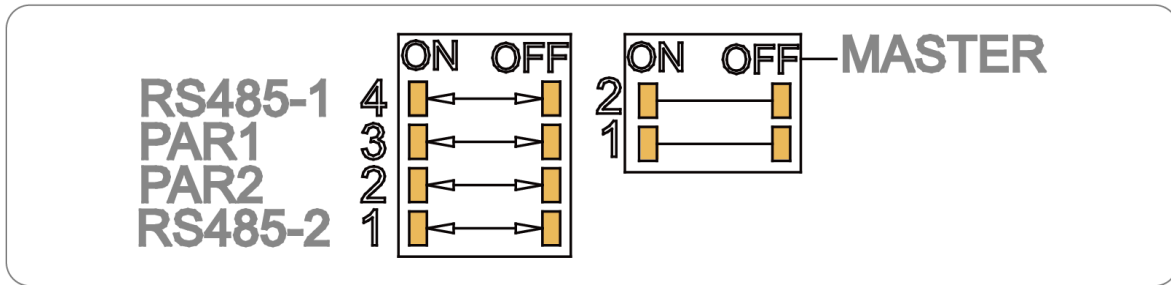

After all the communication cables are connected, turn on the corresponding DIP switch according to the following instructions:

Switch	Description
<b>RS485-1</b>	When the RJ45 <b>RS485-1</b> port is connected on the current inverter, turn on this switch.
<b>PAR1</b> <b>PAR2</b>	In parallel deployment, turn on this switch on the two inverters that are physically farthest apart.
<b>RS485-2</b>	When the three-pin <b>RS485-2</b> port is connected on the current inverter, turn on this switch.
<b>MASTER</b>	In parallel deployment, turn both switches to the <b>ON</b> position on the selected primary inverter.

Table 5.10. DIP switches

## 5.8. Connect the battery cables

The CH3 series inverters support integrating with CB3 C&I battery systems. For detailed cable connection instructions, see *CB3 User Manual*.

## 5.9. Connect the PV cables

Before you begin

**WARNING**

**Risk of electric shock**

Make sure that the two PV switches at the inverter bottom are turned off before the electrical connections.

- Prepare a multimeter with DC voltage range larger than 1500 V. Multimeter of lower measurement range can be damaged.

**PV cable connection guidelines:**

- Evenly distribute the PV input cables across the PV input terminals.
- Maximize the number of MPPT inputs.
- PV strings connected to the same MPPT circuit must use solar panels of the same model and in the same quantity.

Number of PV array	Inverter PV terminal	Number of PV array	Inverter PV terminal
1	PV 1	9	PV 1, 2, 3, 5, 7, 9, 11, 13, 15
2	PV 1, 3	10	PV 1, 2, 3, 4, 5, 7, 9, 11, 13, 15
3	PV 1, 3, 5	11	PV 1, 2, 3, 4, 5, 6, 7, 9, 11, 13, 15
4	PV 1, 3, 5, 7	12	PV 1, 2, 3, 4, 5, 6, 7, 8, 9, 11, 13, 15
5	PV 1, 3, 5, 7, 9	13	PV 1, 2, 3, 4, 5, 6, 7, 8, 9, 10, 11, 13, 15
6	PV 1, 3, 5, 7, 9, 11	14	PV 1, 2, 3, 4, 5, 6, 7, 8, 9, 10, 11, 12, 13, 15
7	PV 1, 3, 5, 7, 9, 11, 13	15	PV 1, 2, 3, 4, 5, 6, 7, 8, 9, 10, 11, 12, 13, 14, 15
8	PV 1, 3, 5, 7, 9, 11, 13, 15	16	PV1-PV16

Table 5.11. MPPT terminal connection guideline

**Procedure**

1. Use a wide-bladed screwdriver to strip off the insulation layer by 20 mm from one end of each PV power cable.

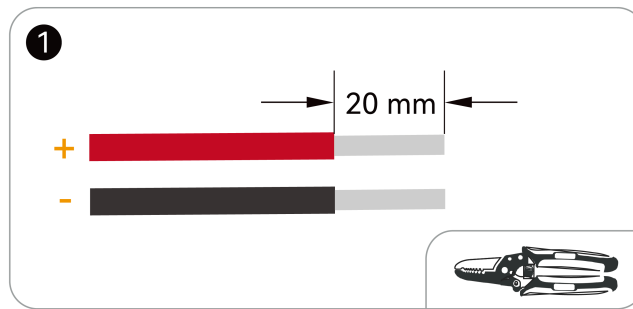

2. Insert the cable ends to the sleeves. Use crimping pliers to assembly the cable ends.

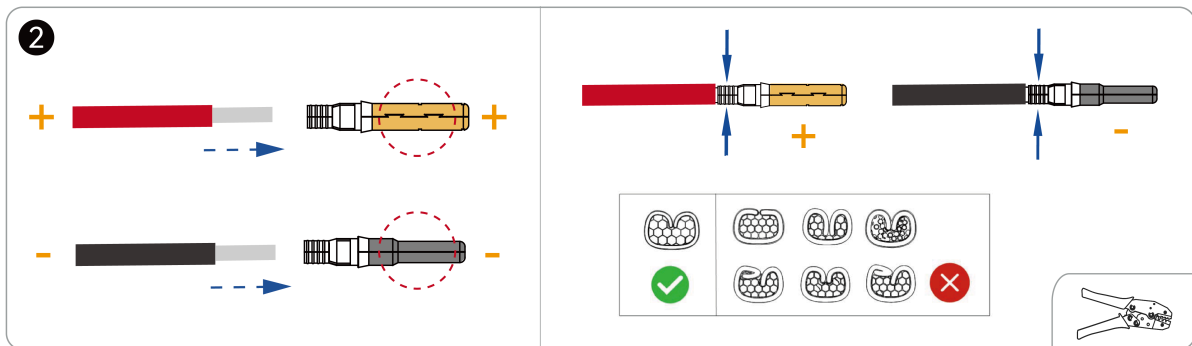

3. Loosen the lock screws on the positive and negative connectors.

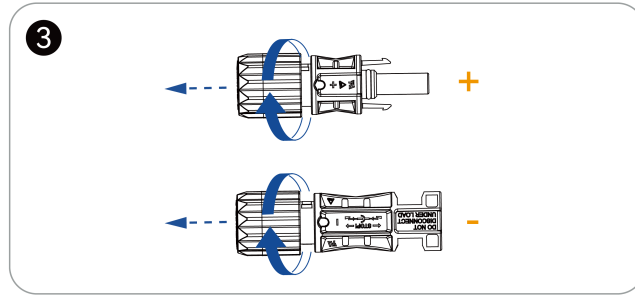

4. Insert the positive and negative cables into the positive and negative connectors. Gently pull the cables backward to ensure firm connection.

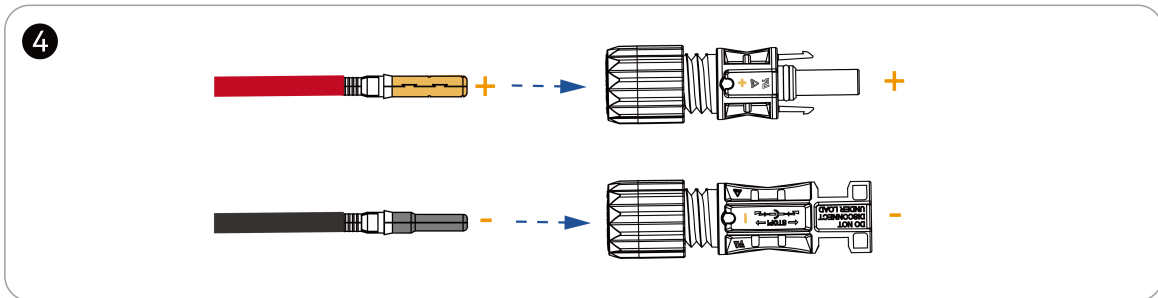

5. Tighten the lock screws on the positive and negative cable connectors with the D4 assembly tool.

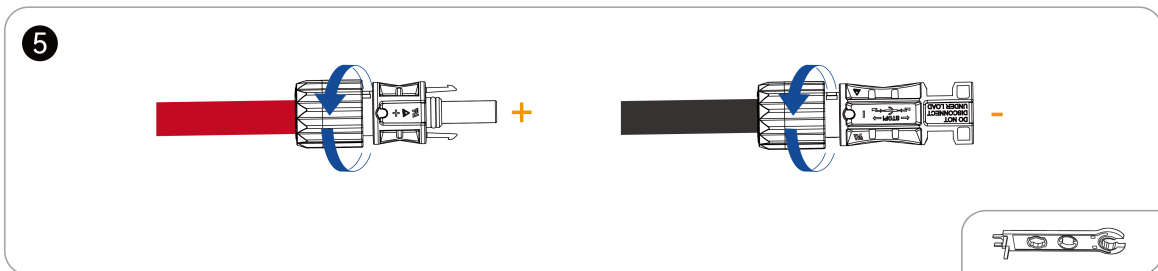

6. Measure the DC voltage of each positive and negative PV input cable with the multimeter. Make sure that each PV input shows DC voltage around 1500 V with correct polarity.

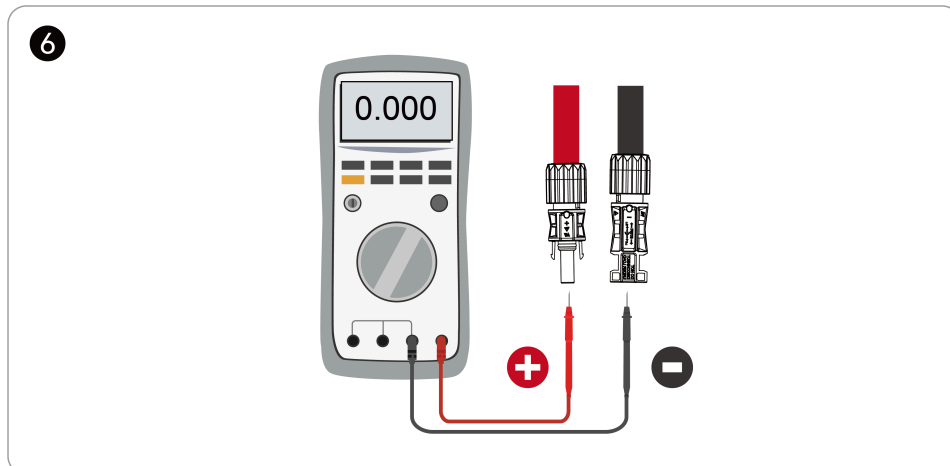

7. Insert the positive and negative cable connectors into the positive and negative PV ports on the inverter until a “click” sound is heard.

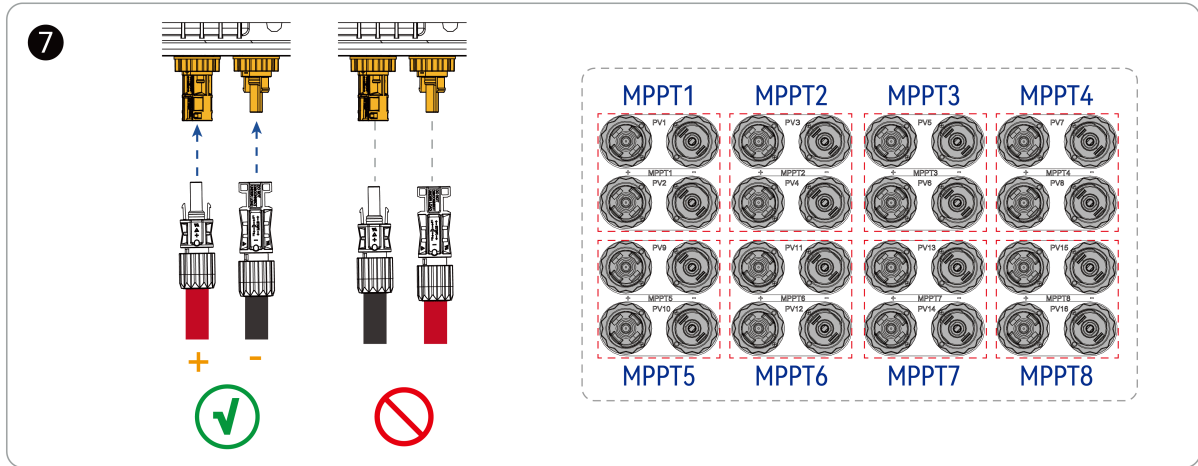

## 6. Startup and Shutdown

### 6.1. Start up the inverter

**Before you begin**

Check that all the cable connections are completed as instructed.

**Procedure**

1. Connect the external AC circuit breaker to turn on the AC power sources.
2. Turn on the two DC switches at the bottom of the inverter to start up the inverter.

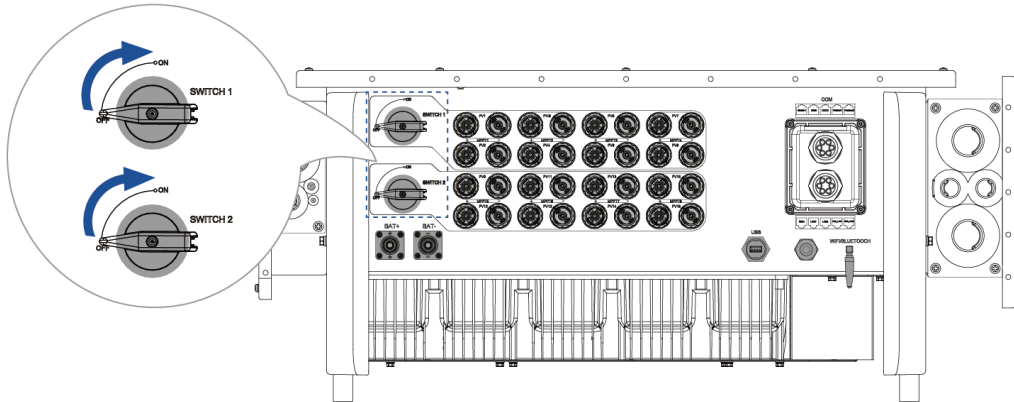

When the **STATE** indicator shows solid green, it indicates that the inverter is up and running.

### 6.2. Shut down the inverter



**Risk of high voltage and electric shock**

Before any operation, disconnect the inverter from all AC and DC power sources and wait at least 5 minutes to allow internal capacitors to discharge.

**Procedure**

1. Disconnect the external AC circuit breaker to turn off the AC power sources.
2. Turn off the two DC switches at the bottom of the inverter.

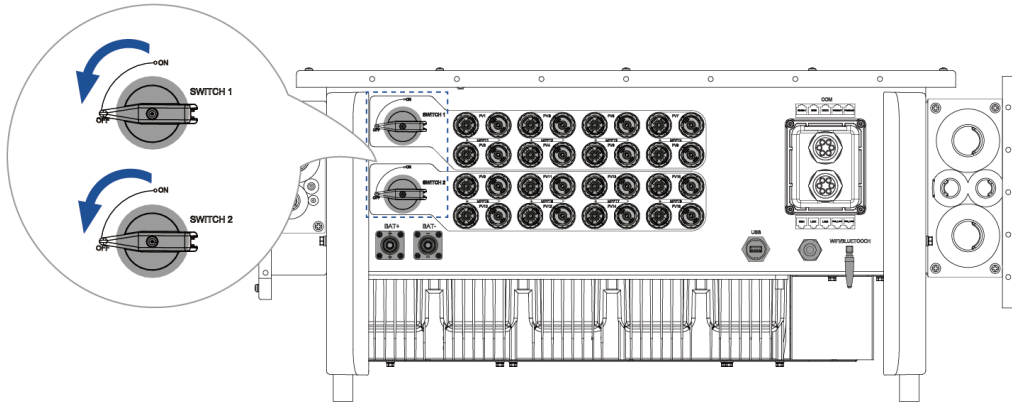

When the **STATE** indicator is off, it indicates that the inverter is powered off.

## 7. Commissioning on App

### 7.1. About elekeeper

The elekeeper is an easy-to-use, AI-powered energy management platform designed for homeowners and businesses. It gives the Owner full control over their energy – from generation and storage to consumption and selling – through a single App that works on phones, tablets, and computers.

**Key features:**

- Real-time, centralized monitoring: The Owner can view the status and performance of all energy devices anytime, anywhere.
- AI-powered scheduling: The system automatically optimizes when to store, use, or sell energy to maximize efficiency and savings.
- Smart diagnostics: The platform detects potential issues early and sends alerts to the Owner before problems occur.
- Actionable insights: Clear, data-driven reports help the Owner make smarter decisions and potentially increase revenue from their energy system.

### 7.2. Download the elekeeper App

Search for "elekeeper" in the App store and download the App.

Alternatively, scan the below QR code to download the App.



**Note:** The detailed operations on the App might vary, depending on the App version in use.

### 7.3. Log in to the elekeeper App

**Procedure**

1. Open the App and tap the three-dot icon ●●● on the top right corner.
2. Set **Language** to English and **Network Node** to European Node or International Node depending on the installation site of the system.

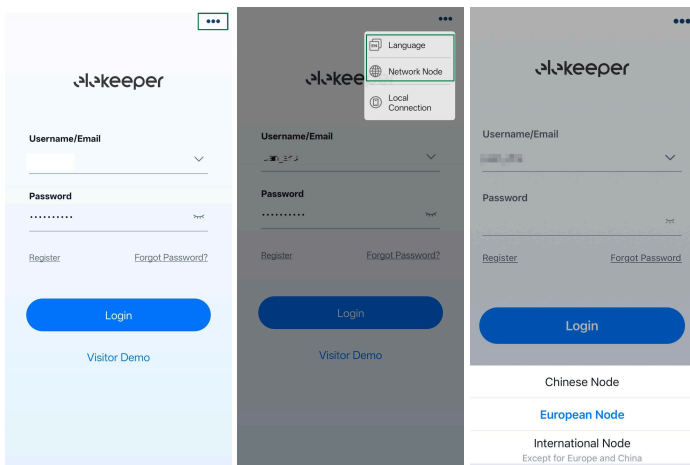

3. If you do not have an account, register first.
  - a. Tap **Register**. Choose whether you are an owner, installer, or distributor.
  - b. Follow the instructions on the screen to complete the registration.

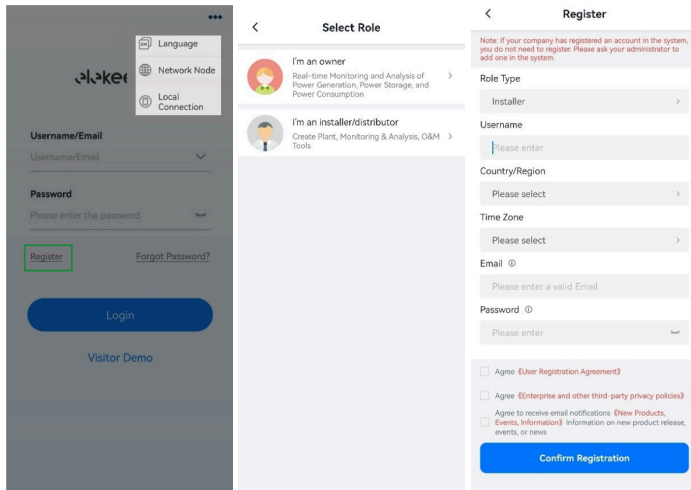

4. Use the account and password to log in to the App.
5. On the **Service** page, select Remote Configuration.
6. Check that Bluetooth is enabled on your mobile phone. Tap **Bluetooth** and then select the communication module or EMS to be connected.

For the communication modules, the **BlueLink** is named with the last five numbers of the inverter's SN or the communication module's SN. For example, 42665.

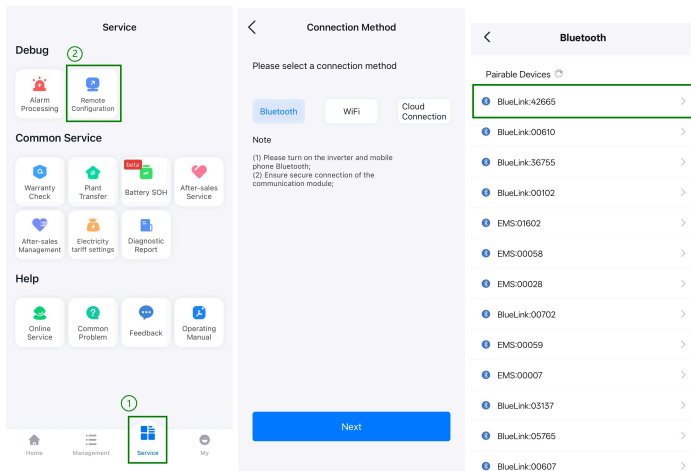

## 7.4. Perform initialization settings

After the eManager is properly installed and connected to the inverter, follow this procedure to initialize the eManager on the elekeeper App.

### Procedure

#### Country and grid compliance settings

1. Log on to the elekeeper App. Enable the Bluetooth function on the mobile phone.
2. Connect to the eManager through Bluetooth connection.

The **BlueLink** is named with the last five numbers of the eManager module SN. For example, **eManager00001**.

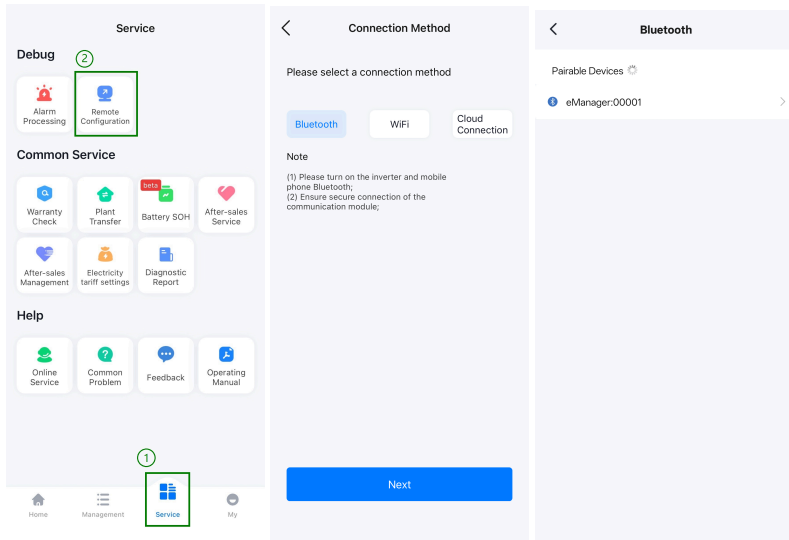

3. Follow the screen to complete the initialization settings.

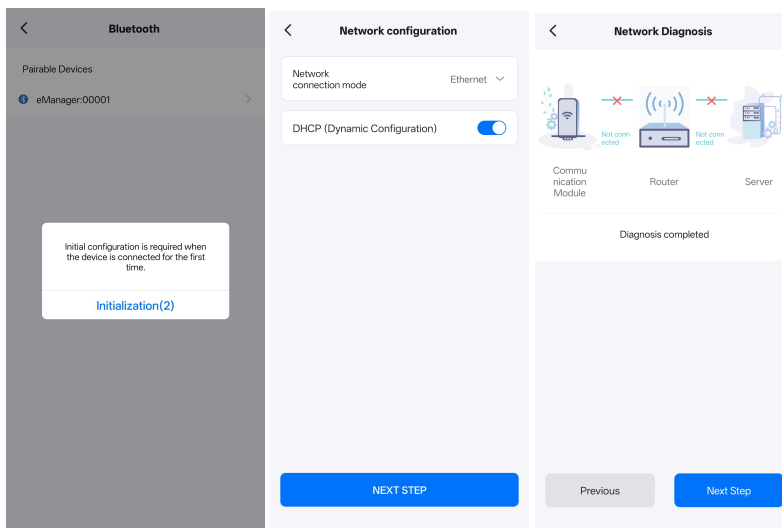

4. On the **Add device** page, check that the inverter is added as connected device.

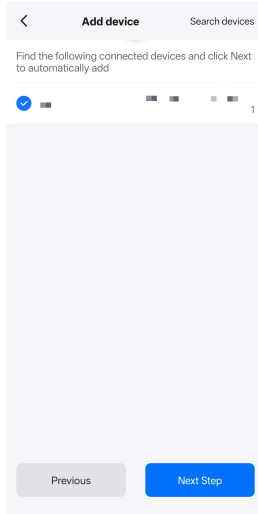

5. On the **Wiring Method** page, select the connected meters.  
**Example: Select Grid meter:**

**Wiring Method**

Select which devices are installed at the power station (multiple selections allowed)

- Grid meter
- PV meter
- Energy storage meter
- ATS
- Photovoltaic controller

Previous    Next Step

6. On the **Strategy configuration** page, select the working policy of the inverter and set the corresponding parameters.

**Example:**

**Strategy configuration**    Template

Current policy ⓘ  
Max Self-Consumption

SOC protection

Upper charge limit  
100 [80 - 100] %

Lower discharge limit  
5 [5 - 20] %

On-Grid Three-Phase Unbalanced Output

Export limitation

Peak shaving

Back-up Mode

Previous    Next Step

---

**Strategy configuration**    Template

On-Grid Three-Phase Unbalanced Output

Export limitation

Mode  
Total Power Mode

Power  
0.0 [-100 - 2000] kW

Peak shaving

Demand Mode  
Limit power

0.0 [0 - 1000000] kW

Peak shaving reserve SOC  
20 [0 - 100] %

Previous    Next Step

7. On the **Battery Brand** page, select the connected battery system.

**Example:** Select **CB3**.

**Battery Brand**

Battery 1 brand  
CB3

No Battery

CB3

Universal Battery Protocol 01

8. On the **Grid Code Settings** page, set the following parameters:

- a. **Country:** the equipment installation location.
- b. **Grid Compliance:** the grid setting.

For Australia, select the specific type of compliance according to the owner's grid configuration.

- **AS4777\_AustraliaA:** For large interconnected power system.
- **AS4777\_AustraliaB:** For small interconnected power systems. For example, Western Power.
- **AS4777\_AustraliaC:** For isolated or remote power systems. For example, Horizon Power and TasNetworks.

c. **Device time:** Tap **AUTO TIME SYNC** to synchronize with the time of the device where the App is installed.

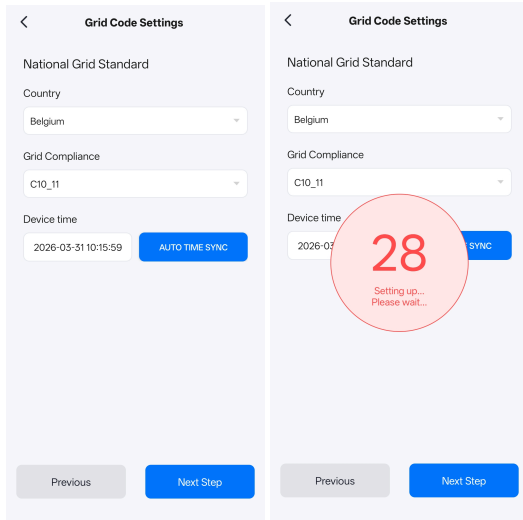

9. After the initialization is completed, check the system status on the following pages:

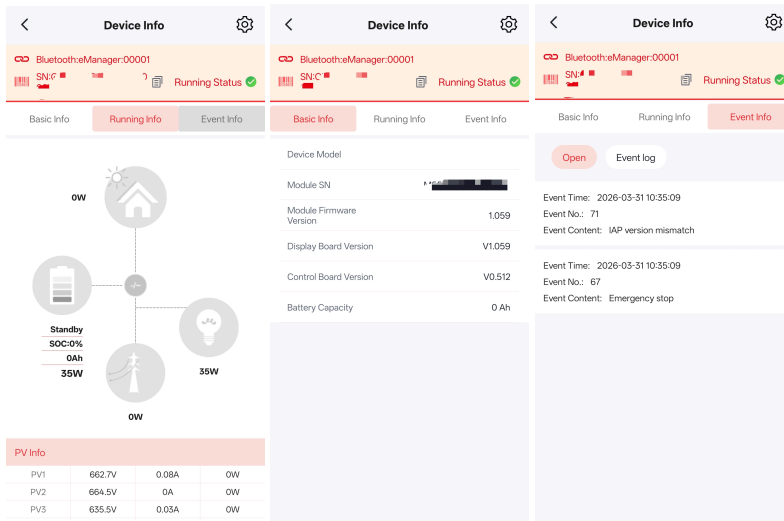

## 7.5. Perform installation diagnosis

After the inverter initialization is completed, perform one-click installation diagnosis to verify the installation status of the system, including the network connection, battery settings, wiring status, and so on.

### Procedure

1. Log in to the elekeeper App and connect to the inverter through Bluetooth connection.
2. On the **Device List** page, tap **Installation diagnosis**.
3. On the **Installation diagnosis** page, tap **One-click diagnosis** to start the diagnosis.  
If the software versions of the inverter are too low, follow the prompt-up to upgrade the system version first.
4. After the diagnosis is completed, check the abnormalities in the report. Handle the issue according to the diagnosis result and the suggested solution.  
If necessary to change the parameter settings, select item on the diagnosis result page.

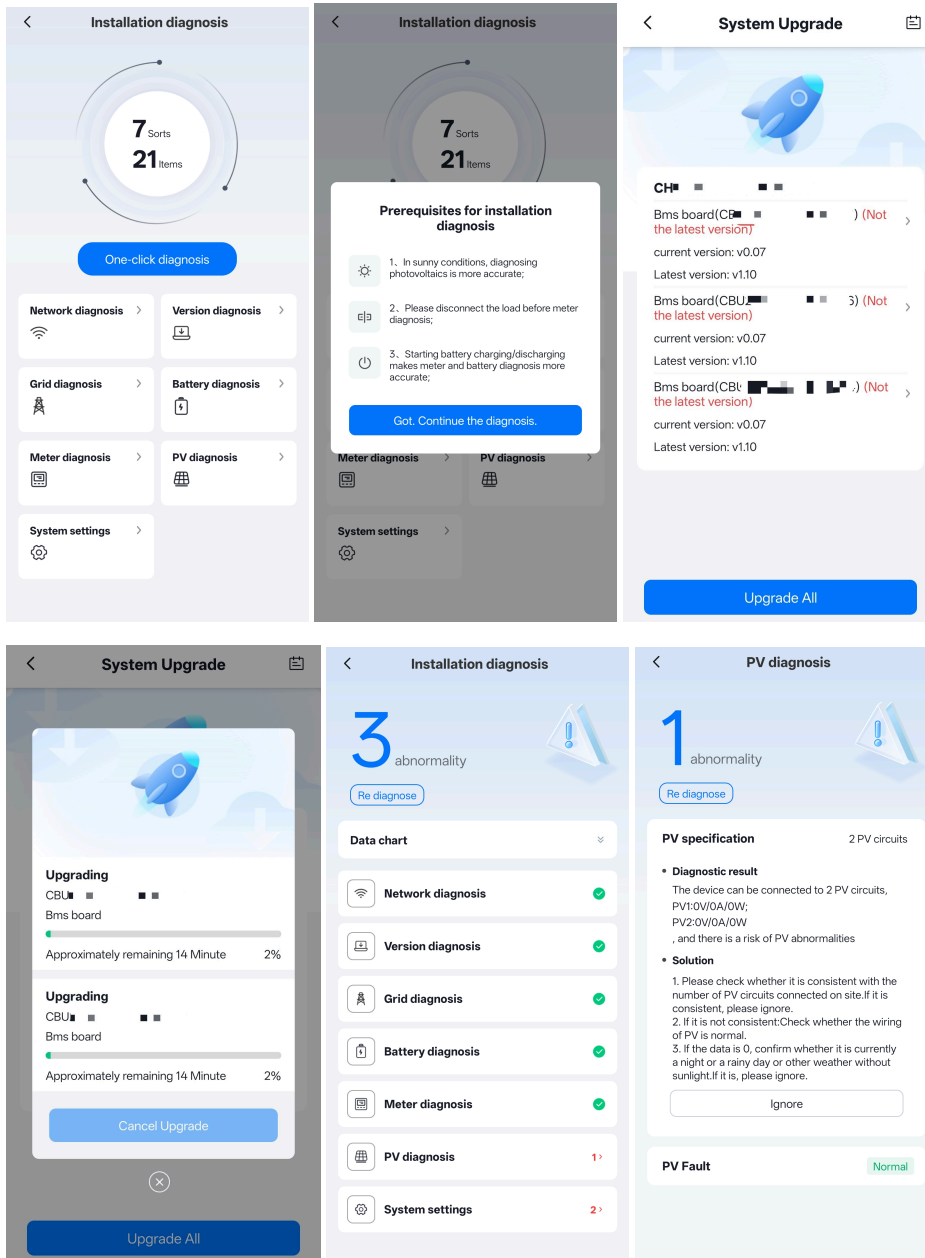

## 7.6. View or change the inverter settings

### Procedure

1. (Installer only) To view the country and grid compliance, perform as follows:

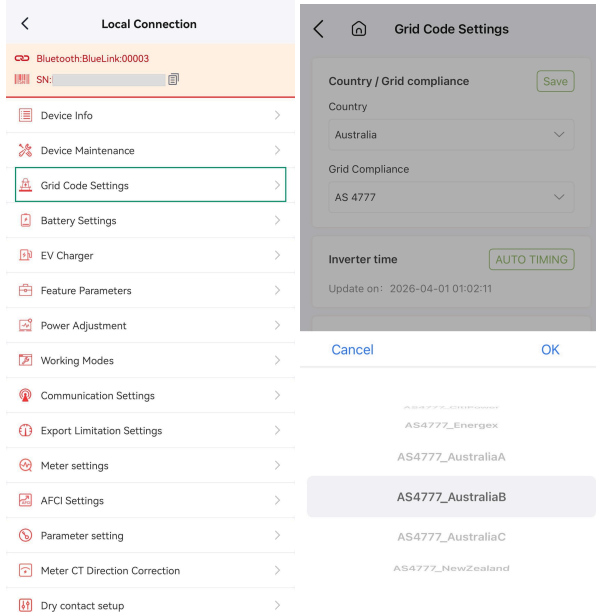

2. (Installer only) To view the protection parameters, perform as follows:

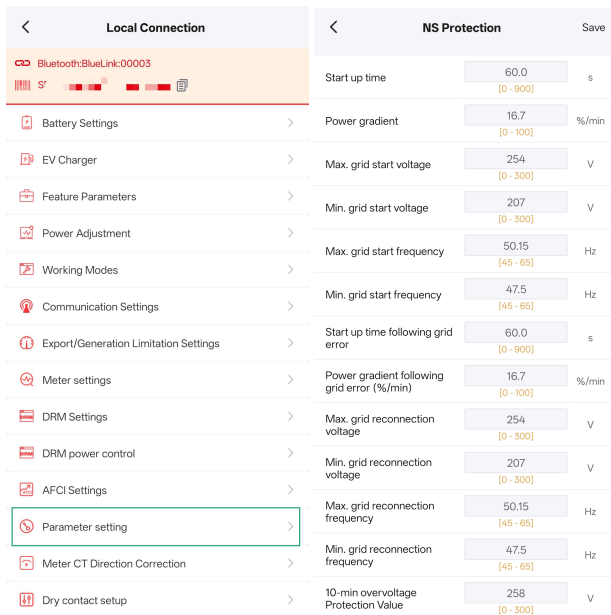

**Note:** Consult SAJ technical support before changing the protection parameters.

3. (Installer only) To view or change the export limit function, perform as follows:

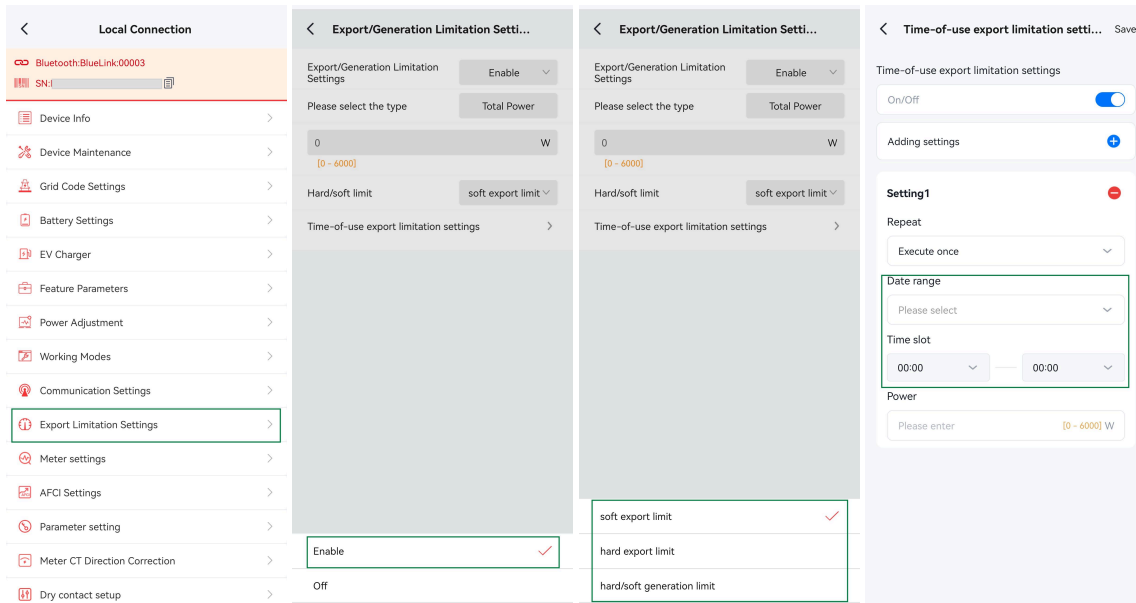

## 7.7. View or configure the V-Watt and Volt-Var modes

This inverter complies with AS/NZS 4777.2: 2020 for power quality response modes. It meets DNSPs' grid connection rules and requirements for the volt-watt and volt-var settings in different regions.

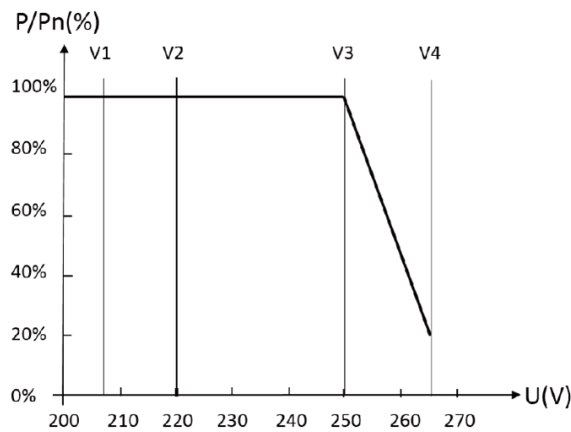

Figure 7.1. Curve for a Volt-Watt response mode (AS4777 Series)

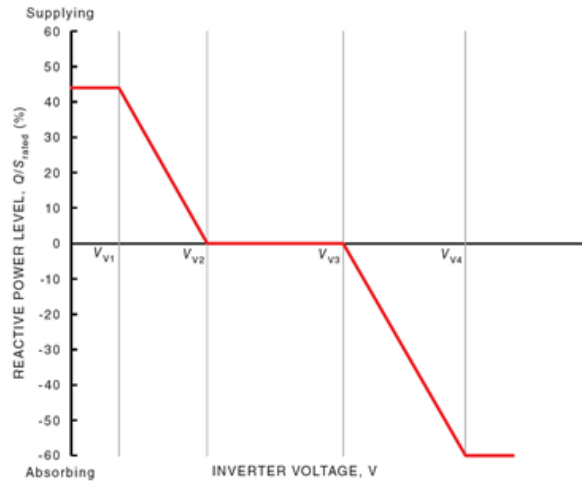

Figure 7.2. Curve for a Volt-Var control mode (AS4777 Series)

**Note:**

With regard to the Power rate limit mode, SAJ sets the product WGr<sub>a</sub> to 16.67%P<sub>n</sub> by default in the following cases according to the requirements of 3.3.5.2 as 4777.2: 2020.

- Soft ramp up after connection.
- Reconnect or soft ramp up/down following a response to frequency disturbance.

**Procedure**

1. Log in to the elekeeper App and connect to the inverter through Bluetooth connection.
2. On the **Device List** page, tap **Grid Code Settings** and check whether the grid compliance is set to Australia grid codes. Change the settings if needed.
3. On the **Device List** page, tap **V-Watt/V-Var** to enter the settings page.

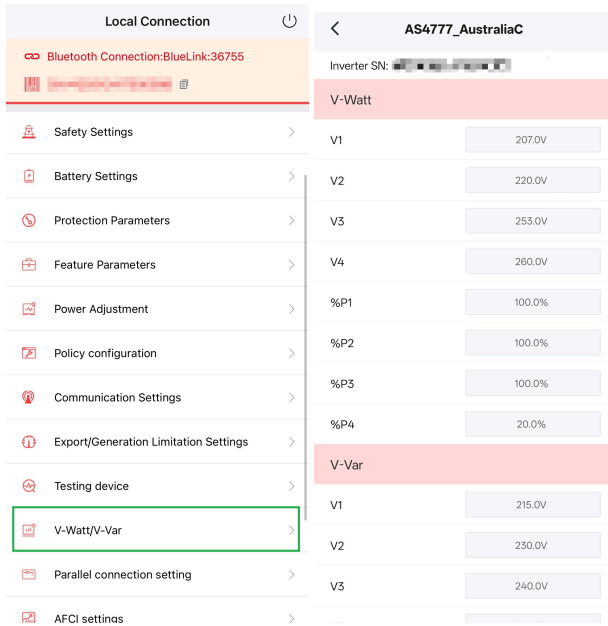

**7.8. Configure the AFCI function**

To enable or disable the AFCI function, on the **Local Connection** page, tap **AFCI Settings**, and choose to enable or disable the anti-arc detection.

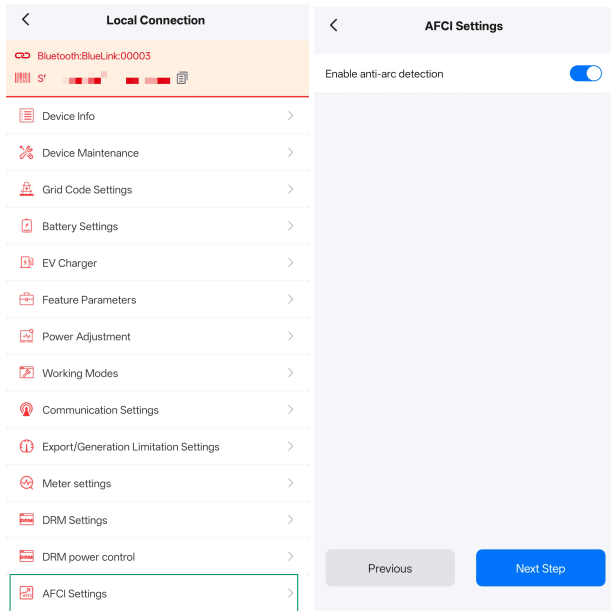

## 7.9. Run self-test for grid connection (For Italy)

### Procedure

1. Log in to the elekeeper App and connect to the inverter through Bluetooth connection.
2. On the **Device List** page, tap **Grid Code Settings** and check whether the grid compliance is set to **Italy** grid codes. Change the settings if needed.

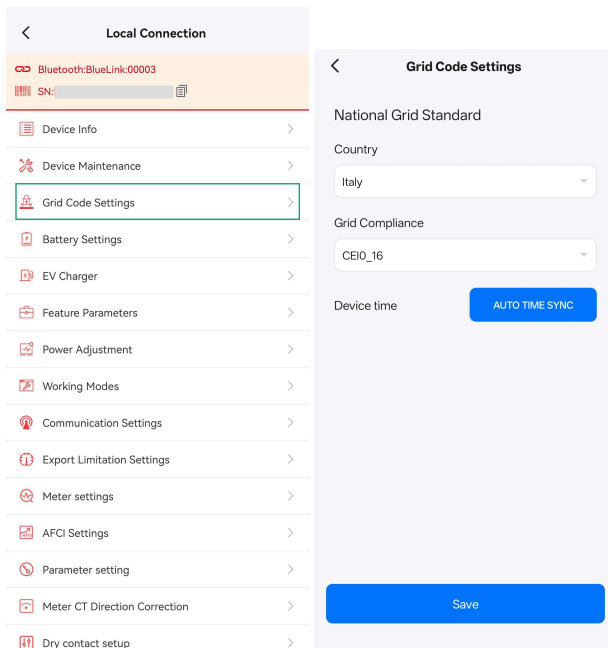

3. On the **Local Connection** page, tap **Self-test**. Choose the self-test items as required. It takes around 5 minutes to complete each item, and around 40 minutes to complete all the items.

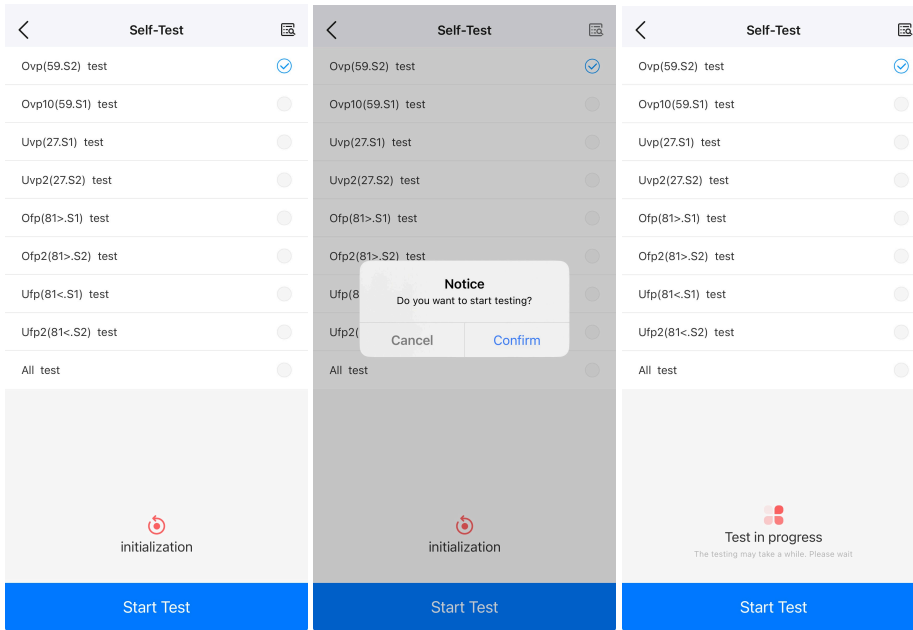

4. After the self-test is completed, tap the search icon on the top right corner to check the test report. Download the test report if the self-test fails and contact **SAJ** or your inverter supplier.

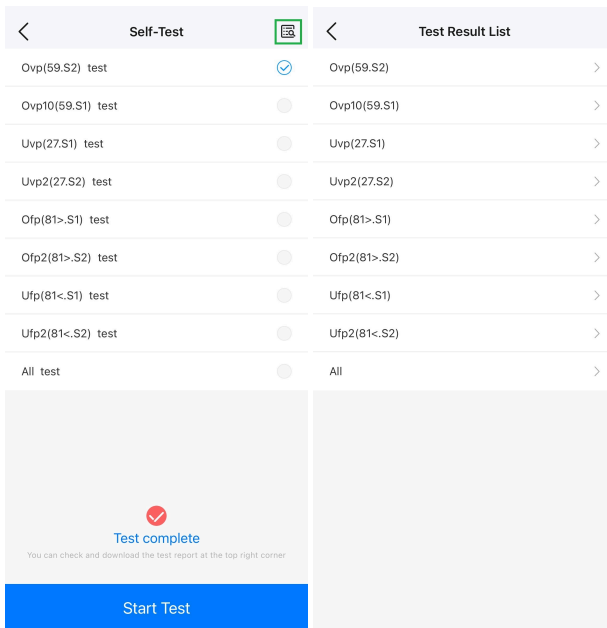

## 8. Operation and maintenance

### 8.1. General safety instructions

#### WARNING

##### Danger of high voltage

- After the system is shut down, wait for at least five minutes to let the energy storage capacitors discharge completely before you take any maintenance operations.
- Only qualified electrical technicians are allowed to perform the maintenance operations.
- Only perform the maintenance operations in clear and dry weather with no wind or sand. Do not open the AC cable cabinets in weather conditions such as rain, snow, thunderstorms, sandstorms, or heavy fog.
- Do not allow any items (such as fingers, parts, screws, or tools) to contact the fan until it has been powered off and has completely stopped rotating to prevent mechanical injuries.

#### CAUTION

- Do not leave any screws, washers, or other metal parts inside the AC cable cabinets. It can cause short circuits, arc discharges, or other electrical faults, which can lead to serious incidents such as fires or explosions.
- Sand or impact of moisture could damage the electrical components and affect the operating performance of the system.

To ensure the safety and efficiency of maintenance work on the inverter, it is essential to strictly follow these safety operating procedures:

- There must be at least two people or more on-site during maintenance work to assist and respond in emergencies.
- During maintenance, use insulating materials to cover nearby live components to prevent accidental electric shock.
- Do not power on the equipment before completing fault diagnosis to avoid new faults or safety hazards.
- For switches that need to be disconnected for maintenance, place a "Do Not Close" warning sign at the switch location to prevent accidental operation.
- After replacing power components or changing wiring in the system, manually start the wiring detection and topology recognition process to ensure normal system operation and avoid abnormalities.

### 8.2. Regular maintenance

Conduct regular maintenance of the product to ensure its long-term stable operation.

The maintenance cycles provided in this section are for reference; actual maintenance cycles should be adjusted based on the specific environmental conditions at the project site. Especially in harsh environments such as desert areas, maintenance cycles should be shortened, and cleaning and anti-corrosion measures should be more frequent.

Maintenance item	Method	Interval
Air inlet and outlet cleaning and fan inspection	<ul style="list-style-type: none"> <li>• Check if there is dust accumulation at the air inlets and outlets. If necessary, remove the baffles for cleaning.</li> <li>• Check for any abnormal noise while the fan is running.</li> </ul>	Once every six months to one year.

Maintenance item	Method	Interval
System operating status	<ul style="list-style-type: none"> <li>• Check if the inverter appearance is damaged or deformed.</li> <li>• Check for any abnormal sound during inverter operation.</li> <li>• While the inverter is running, verify that all parameters are set correctly on the elekeeper App.</li> </ul>	Once every six months
Electrical connections	<ul style="list-style-type: none"> <li>• Check if cable connections are detached or loose.</li> <li>• Check cables for damage, specifically looking for scratches on surfaces in contact with metal.</li> <li>• Check if the sealing plugs for unused DC input terminals have fallen off. Ensure waterproof covers are installed on unused terminals and ports.</li> </ul>	<ul style="list-style-type: none"> <li>• First time: six months after commissioning.</li> <li>• Subsequently: Once every six months to one year.</li> </ul>
Grounding reliability	Check whether the ground cable is securely and reliably grounded.	<ul style="list-style-type: none"> <li>• First time: six months after commissioning.</li> <li>• Subsequently: Once every six months to one year.</li> </ul>
Vegetation clearing around inverter	<ul style="list-style-type: none"> <li>• Proactively perform inspection and weeding before the dry/withering season.</li> <li>• Promptly remove debris after clearing; do not stack it around the inverter.</li> </ul>	Based on the local dry/withering season.

Table 8.1. Maintenance Operations

## 9. Troubleshooting

For the errors reported as below, take the suggested troubleshooting actions in the listed order first. If the error is still present after taking the suggested actions or no specific action is suggested, contact the service support for further assistance.

### NOTICE

The troubleshooting operations must be performed by authorized technicians.

Error code	Error message	Cause	Troubleshooting actions
1	Master Relay Error	<ol style="list-style-type: none"> <li>The live wire is grounded on the grid side.</li> <li>The grid voltage is too low.</li> <li>The inverter relay circuit is faulty.</li> </ol>	<ol style="list-style-type: none"> <li>Measure whether the voltage between the ground wire and the neutral wire is greater than 10V.</li> <li>Measure whether the grid voltage is too low.</li> </ol>
2	Master EEPROM Error	Internal EEPROM failure of the inverter.	<ol style="list-style-type: none"> <li>After turning off the AC/DC switch for 5 minutes, restart the inverter.</li> <li>Check whether the firmware is upgraded to the correct version.</li> </ol>
3	Master Temperature High Error	The inverter temperature is too high.	<ol style="list-style-type: none"> <li>Check whether the heat dissipation channel of the inverter is blocked.</li> <li>Check whether the inverter is installed in a location exposed to direct sunlight.</li> <li>Check whether the installation environment is well-ventilated.</li> </ol>
4	Master Temperature Low Error	The inverter temperature is too low.	<ol style="list-style-type: none"> <li>Check whether the ambient temperature of the inverter installation location too low.</li> </ol>
5	Lost Communication M<->S	Internal communication of the inverter is lost.	After turning off the AC and DC switch for 5 minutes, restart the inverter.
6	GFCI Device Error	The inverter GFCI device fails.	After turning off the AC and DC switch for 5 minutes, restart the inverter.
7	DCI Device Error	The inverter DCI device fails.	After turning off the AC and DC switch for 5 minutes, restart the inverter.
8	Current Sensor Error	The inverter current sensor malfunctions.	<ol style="list-style-type: none"> <li>After turning off the AC and DC switch for 5 minutes, restart the inverter.</li> <li>Whether the positive and negative poles of the string MC4 connectors are reversed.</li> </ol>
9	Master Phase1 Voltage High	The grid voltage is higher than the inverter safety regulations.	<ol style="list-style-type: none"> <li>Check whether the grid voltage is too high.</li> <li>Check whether the inverter AC output cable connection is secure and whether the grid-connected cable is too thin.</li> <li>Check whether the inverter grid compliance is selected correctly on the App.</li> </ol>

Error code	Error message	Cause	Troubleshooting actions
10	Master Phase1 Voltage Low	The grid voltage is lower than the allowed range of the inverter safety regulations.	<ol style="list-style-type: none"> <li>1. Check whether the grid voltage is too low.</li> <li>2. Check whether the inverter AC output cable connection is secure.</li> <li>3. Check whether the inverter grid compliance is selected correctly on the App.</li> </ol>
11	Master Phase2 Voltage High	The grid voltage is higher than the inverter safety regulations allow.	<ol style="list-style-type: none"> <li>1. Check whether the grid voltage is too high.</li> <li>2. Check whether the inverter AC output cable connection is secure and whether the grid-connected cable is too thin.</li> <li>3. Check whether the inverter grid compliance is selected correctly on the App.</li> </ol>
12	Master Phase2 Voltage Low	The grid voltage is lower than the allowed range of the inverter safety regulations.	<ol style="list-style-type: none"> <li>1. Check whether the grid voltage is too low.</li> <li>2. Check whether the inverter AC output cable connection is secure.</li> <li>3. Check whether the inverter grid compliance is selected correctly on the App.</li> </ol>
13	Master Phase3 Voltage High	The grid voltage is higher than the inverter safety regulations.	<ol style="list-style-type: none"> <li>1. Check whether the grid voltage is too high.</li> <li>2. Check whether the inverter AC output cable connection is secure and whether the grid-connected cable is too thin.</li> <li>3. Check whether the inverter grid compliance is selected correctly on the App.</li> </ol>
14	Master Phase3 Voltage Low	The grid voltage is lower than the allowable range of the inverter safety regulations.	<ol style="list-style-type: none"> <li>1. Check whether the grid voltage is too low.</li> <li>2. Check whether the inverter AC output cable connection is secure.</li> <li>3. Check whether the inverter grid compliance is selected correctly on the App.</li> </ol>
15	Grid Voltage 10Min High	The grid voltage is higher than the inverter safety regulations.	<ol style="list-style-type: none"> <li>1. Check whether the grid voltage is too high.</li> <li>2. Check whether the inverter AC output cable connection is secure and whether the grid-connected cable is too thin.</li> <li>3. Check whether the inverter grid compliance is selected correctly on the App.</li> </ol>
16	OffGrid Output Voltage Low	The system temperature is too high, causing the battery to reduce load output.	<ol style="list-style-type: none"> <li>1. Check whether the ambient temperature is too high.</li> <li>2. Check whether the inverter heat dissipation channel is blocked.</li> <li>3. Check whether the inverter is installed in a location exposed to direct sunlight.</li> </ol>
17	OffGrid Output Short Circuit	External wiring short circuit on back-up side.	Check the external cable connections on the back-up side.
18	Master Grid Frequency High	The grid frequency is higher than the upper limit specified by the local power grid.	<ol style="list-style-type: none"> <li>1. Check whether the grid compliance of the inverter is selected correctly on the App.</li> <li>2. After 5 minutes of disconnecting the AC and DC switch, restart the inverter.</li> </ol>

Error code	Error message	Cause	Troubleshooting actions
19	Master Grid Frequency Low	The grid frequency is lower than the lower limit specified by the local power grid.	<ol style="list-style-type: none"> <li>1. Check whether the grid compliance of the inverter is selected correctly on the App.</li> <li>2. After 5 minutes of disconnecting the AC and DC switch, restart the inverter.</li> </ol>
20	BATInputMode Error	The actual battery connection is not parallel connection.	<ol style="list-style-type: none"> <li>1. Check whether all battery connections are secure.</li> <li>2. Check whether the battery input mode is configured to parallel mode.</li> </ol>
21	Phase1 DCV High	The DC component of the AC L1 output exceeds the limit range.	After turning off the AC/DC switch for 5 minutes, restart the inverter.
22	Phase2 DCV High	The DC component of the AC L2 output exceeds the limit range.	After turning off the AC/DC switch for 5 minutes, restart the inverter.
23	Phase3 DCV High	The DC component of the AC L3 output exceeds the limit range.	After turning off the AC/DC switch for 5 minutes, restart the inverter.
24	Master No Grid Error	The inverter cannot detect the grid voltage.	<ol style="list-style-type: none"> <li>1. Confirm whether there is a power outage in the power grid.</li> <li>2. Check whether the grid-connected box switch is tripped.</li> <li>3. Check whether the inverter AC cable is firmly connected.</li> </ol>
25	DC ReverseConnect Error	There is a reverse connection at the PV or battery port.	Check whether the negative and positive cables at the PV side and the battery side are connected correctly.
26	Parallel machine CAN Com Error	Parallel CAN communication failed.	Check the cable connections for parallel CAN communication.
27	GFCI Error	A ground leakage current fault was detected in the power station system.	<ol style="list-style-type: none"> <li>1. Turn off the AC and DC switches and wait for 5 minutes.</li> <li>2. Check whether the ground wire of the AC output end is firm, and whether the AC wiring is correct.</li> <li>3. Check whether the AC and DC cables are damaged or soaked in water, and whether the battery board is soaked in water.</li> </ol>
28	Phase1 DCI High	The DC component of the AC L1 output exceeds the limit range.	After turning off the AC/DC switch for 5 minutes, restart the inverter.
29	Phase2 DCI High	The DC component of the AC L2 output exceeds the limit range.	After turning off the AC/DC switch for 5 minutes, restart the inverter.
30	Phase3 DCI High	The DC component of the AC L3 output exceeds the limit range.	After turning off the AC/DC switch for 5 minutes, restart the inverter.

Error code	Error message	Cause	Troubleshooting actions
31	ISO Error	The insulation resistance between the string and the ground is less than the set value.	<ol style="list-style-type: none"> <li>1. Turn off the AC and DC switches and wait for 5 minutes.</li> <li>2. Check whether the PV and battery cables are damaged or soaked in water.</li> <li>3. Check whether the battery board is soaked in water.</li> <li>4. Check whether the resistance from the PV and battery DC lines (both positive and negative) to the ground is high enough.</li> </ol>
32	Bus Voltage Imbalance	The voltage distribution among the three phases is unequal.	After turning off the AC/DC switch for 5 minutes, restart the inverter.
33	Master Bus Voltage High	The DC input voltage exceeds the allowed input limit of the inverter.	<ol style="list-style-type: none"> <li>1. Check the number of battery panels in each string and calculate whether the open circuit voltage of the string exceeds the maximum input voltage of the inverter.</li> <li>2. If the above items are normal, turn off the AC/DC switch for 5 minutes, and then restart the inverter.</li> </ol>
34	Master Bus Voltage Low	The bus voltage of the inverter is too low.	After turning off the AC/DC switch for 5 minutes, restart the inverter.
35	Master Grid Phase Error	Grid phase error.	Check the phase relationship by using a phase rotation meter or swapping the three-phase cables to locate the error.
36	Master PV Voltage High	The DC input voltage of the inverter is too high.	<ol style="list-style-type: none"> <li>1. Check the number of battery panels in each string and calculate whether the open circuit voltage of the string exceeds the maximum input voltage of the inverter.</li> <li>2. If the above items are normal, turn off the AC/DC switch for 5 minutes, and then restart the inverter.</li> </ol>
37	Master Islanding Error	Loss of power grid causes islanding.	<ol style="list-style-type: none"> <li>1. Confirm whether there is a power outage in the power grid.</li> <li>2. Check whether the grid-connected box switch is tripped, and whether the inverter AC cables are firmly connected.</li> <li>3. Close the AC switch and reconnect to the grid.</li> </ol>
38	Master HW Bus Voltage High	The DC input voltage exceeds the allowed input limit of the inverter.	<ol style="list-style-type: none"> <li>1. Check the number of battery panels in each string and calculate whether the open circuit voltage of the string exceeds the maximum input voltage of the inverter.</li> <li>2. If the above items are normal, turn off the AC/DC switch for 5 minutes, and then restart the inverter.</li> </ol>
39	Master HW PV Current High	<ol style="list-style-type: none"> <li>1. The positive and negative poles of the string are connected reversely.</li> <li>2. The inverter is internally damaged.</li> </ol>	<ol style="list-style-type: none"> <li>1. Check whether the positive and negative poles of the string are reversely connected.</li> <li>2. If the above items are normal, turn off the AC/DC switch for 5 minutes, and then restart the inverter.</li> </ol>
40	Master Self-Test Failed	Inverter power-on self-test abnormality.	Contact technical support for further assistance.

Error code	Error message	Cause	Troubleshooting actions
41	Master HW Inv Current High	The grid-side output current exceeds the inverter limit.	<ol style="list-style-type: none"> <li>1. Turn off the AC and DC switch and check whether the AC cable is firmly connected.</li> <li>2. If the above items are normal, turn off the AC/DC switch for 5 minutes, and then restart the inverter.</li> </ol>
42	Master AC SPD Error	AC lightning protection circuit abnormality.	Contact technical support for further assistance.
43	Master DC SPD Error	DC lightning protection circuit abnormality.	Contact technical support for further assistance.
44	Master Grid NE Voltage Error	Live line grounding occurs on the grid side.	<ol style="list-style-type: none"> <li>1. Check whether the grounding cable connection is firm and secure.</li> <li>2. Measure whether the voltage between the ground wire and the neutral wire is greater than 10V. If it is greater than 10V, the live wire is grounded.</li> </ol>
45	Master Fan1 Error	Fan 1 blades are stuck or damaged.	<ol style="list-style-type: none"> <li>1. Check whether the external fan (if any) is running normally.</li> <li>2. Turn off the AC and DC switch, waiting for 5 minutes, and then restart the inverter.</li> </ol>
46	Master Fan2 Error	Fan 2 blades are stuck or damaged.	<ol style="list-style-type: none"> <li>1. Check whether the external fan (if any) is running normally.</li> <li>2. Turn off the AC and DC switch, waiting for 5 minutes, and then restart the inverter.</li> </ol>
47	Master Fan3 Error	Fan 3 blades are stuck or damaged.	<ol style="list-style-type: none"> <li>1. Check whether the external fan (if any) is running normally.</li> <li>2. Turn off the AC and DC switch, waiting for 5 minutes, and then restart the inverter.</li> </ol>
48	Master Fan4 Error	Fan 4 blades are stuck or damaged.	<ol style="list-style-type: none"> <li>1. Check whether the external fan (if any) is running normally.</li> <li>2. Turn off the AC and DC switch, waiting for 5 minutes, and then restart the inverter.</li> </ol>
49	Lost Communication between Master and Meter	Abnormal communication between inverter and meter.	<ol style="list-style-type: none"> <li>1. Confirm whether the meter is working normally.</li> <li>2. Check whether the communication cable connection between the inverter and the meter is secure.</li> <li>3. Check whether the communication parameters between the inverter and the meter are set correctly, including address, baud rate, and so on.</li> </ol>
50	Lost Communication between M<->S	Internal communication of the inverter is lost.	After turning off the AC/DC switch for 5 minutes, restart the inverter.
51	Lost Communication between inverter and Grid Meter	The communication between the inverter and the grid meter is abnormal.	<ol style="list-style-type: none"> <li>1. Confirm whether the meter is working normally.</li> <li>2. Check whether the communication cable connection between the inverter and the meter is secure.</li> <li>3. Check whether the communication parameters between the inverter and the meter are set correctly, including address, baud rate, and so on.</li> </ol>

Error code	Error message	Cause	Troubleshooting actions
52	HMI EEPROM Error	Internal EEPROM failure of the inverter.	<ol style="list-style-type: none"> <li>1. After turning off the AC/DC switch for 5 minutes, restart the inverter.</li> <li>2. Check whether the firmware is upgraded to the correct version.</li> </ol>
53	HMI RTC Error	RTC error.	Contact technical support for further assistance.
54	BMS Device Error	Battery abnormality.	Contact technical support for further assistance.
55	BMS Lost.Conn	BMS does not start normally.	Check whether the BMS START button is on.
56	CT Device Err	CT Device Err	Contact technical support for further assistance.
57	AFCI Lost Com.Err	AFCI board communication interrupted.	Contact technical support for further assistance.
67	Emergency stop	Emergency stop button pressed.	Reset the emergency stop button.
69	Fire lockout fault	The fire alarms are triggered, including smoke, flooding, or aerosol alarms.	<ol style="list-style-type: none"> <li>1. Check whether the cabinet is free of any smoke, water immersion, or abnormal situation.</li> <li>2. If the cabinet is working properly, clear the alarm manually on the App.</li> </ol>
81	Lost Communication D<->C	Internal communication of the inverter is lost.	After turning off the AC/DC switch for 5 minutes, restart the inverter.
83	Master Arc Device Error	Arc Device Error.	Contact technical support for further assistance.
84	Master PV Mode Error	PV mode selection error.	Check whether the inverter string mode is set correctly.
85	Authority expires	Authority expires.	Contact technical support for further assistance.
86	DRM0 Error	DRM0 Error	Contact technical support for further assistance.
87	Master Arc Error	DC arcing caused by DC short circuit or poor terminal contact.	<ol style="list-style-type: none"> <li>1. Check whether each terminal is in good contact and whether the PV positive and negative insulation to the ground is normal.</li> <li>2. If the above items are normal, turn off the AC and DC switch, waiting for 5 minutes, and then restart the inverter.</li> </ol>
88	Master SW PV Current High	<ol style="list-style-type: none"> <li>1. The positive and negative poles of the string are connected reversely.</li> <li>2. The inverter is internally damaged.</li> </ol>	<ol style="list-style-type: none"> <li>1. Check whether the positive and negative poles of the string are reversely connected.</li> <li>2. If the above items are normal, turn off the AC and DC switch, waiting for 5 minutes, and then restart the inverter.</li> </ol>
89	Battery Voltage High	The battery voltage is higher than the maximum voltage value of the inverter.	Contact technical support for further assistance.
90	Battery Current High	The battery power is too low or the load is too large, causing the battery unable to output.	<ol style="list-style-type: none"> <li>1. Reduce the back-up load.</li> <li>2. Charge the battery or stop using the battery.</li> </ol>
91	Battery Charge Voltage High	The voltage is too high during battery charging.	<ol style="list-style-type: none"> <li>1. Do not turn off the battery during charging.</li> <li>2. Restart the battery and the inverter.</li> </ol>

Error code	Error message	Cause	Troubleshooting actions
92	Battery OverLoad	The battery power is too low or the load is too large, causing the battery to be unable to output.	1. Reduce the back-up load. 2. Charge the battery or stop using the battery.
93	Battery SoftConnet TimeOut	Battery precharge bus failed.	Contact technical support for further assistance.
94	Output OverLoad	The load connected to the back-up end is greater than the maximum output power of the inverter.	Reduce the back-up load.
95	Battery Open Circuit	Inverter cannot detect battery voltage.	1. Check whether the battery circuit breaker is open. 2. Check whether the connection of the battery power cables is secure.
96	Battery Discharge Voltage Low	Low voltage is detected during battery discharge.	Do not turn off the battery during battery discharge.
97	BMS Internal Communication Error	1. The communication between the battery high-voltage box and the battery pack is abnormal. 2. The last battery pack was not connected to the resistor plug, which causes the high voltage box fail to recognize the number of battery packs.	1. Check whether the communication cable is correctly connected. 2. Check whether the last battery pack has a resistor plug. 3. Check whether the communication network is working.
98	Bat Sequence Error	Battery pack communication abnormality.	1. Check whether the communication cable is correctly connected. 2. Check whether the last battery pack has a resistor plug. 3. Check whether the communication network is working.
99	Discharge Over Current Protection	The discharge current exceeds the set threshold.	Wait for the fault to be cleared automatically or restart the inverter.
100	Charge Over Current Protection	The charge current exceeds the set threshold.	Wait for the fault to be cleared automatically or restart the inverter.
101	Module Under Voltage Protection	The total pressure is lower than the set threshold.	Force charging the battery.
102	Module Over Voltage Protection	The total pressure is higher than the set threshold.	Wait for the fault to be cleared automatically or restart the inverter.
103	Single Cell Under Voltage Protection	The cell voltage is lower than the set maximum value.	Force charging the battery.

Error code	Error message	Cause	Troubleshooting actions
104	Single Cell Over Voltage Protection	The cell voltage is higher than the set maximum value.	Wait for the fault to be cleared automatically or restart the inverter.
105	BMS Hardware Error	<ol style="list-style-type: none"> <li>1. Single voltage detection module failure.</li> <li>2. Temperature detection module failure.</li> <li>3. Current detection module failure.</li> </ol>	After turning off the AC/DC switch for 5 minutes, restart the inverter.
106	Charging temperature low protection	Charging the battery below 0°C.	Wait for the battery to heat up until the fault is cleared.
107	Charging temperature high protection	Battery temperature is too high.	Wait for the battery to cool down until the fault is cleared.
108	Discharging temperature low protection	The battery temperature is too low, disconnect the relay to stop discharging.	Wait for the battery to heat up until the fault is cleared.
109	Discharging temperature high protection	Battery temperature is too high.	Wait for the battery to cool down until the fault is cleared.
110	BMS Relay Error	<ol style="list-style-type: none"> <li>1. The negative or positive relay is stuck.</li> <li>2. The negative or positive relay cannot be closed.</li> </ol>	After turning off the AC/DC switch for 5 minutes, restart the inverter.
111	Pre-charge Error	<ol style="list-style-type: none"> <li>1. The precharge relay is damaged.</li> <li>2. Precharge blocking circuit.</li> <li>3. BMS damaged.</li> </ol>	After turning off the AC/DC switch for 5 minutes, restart the inverter.
112	BMS Insulation Error	The battery pack may have a leakage problem.	Contact technical support for further assistance.
113	BMS supplier Incompatibility	The battery pack and the BMS used in the high-voltage box do not match.	Contact technical support for further assistance.
114	Battery cell supplier incompatibility	Battery pack cell manufacturers are inconsistent.	Contact technical support for further assistance.
115	Battery cell incompatibility	Battery pack cell levels are inconsistent.	Contact technical support for further assistance.
116	Battery pack models incompatibility	The battery pack model does not match.	Contact technical support for further assistance.
117	Circuit Breaker Is Open	<ol style="list-style-type: none"> <li>1. The battery circuit breaker is not closed.</li> <li>2. The battery circuit breaker auxiliary contact is abnormal.</li> </ol>	Close the battery air switch.

Error code	Error message	Cause	Troubleshooting actions
118	Temperature Difference Is Too Wide	Temperature detection module error.	After turning off the AC/DC switch for 5 minutes, restart the inverter.
119	Voltage Difference Is Too Wide (Class II)	The sampling line is loose.	After turning off the AC/DC switch for 5 minutes, restart the inverter.
120	Voltage Difference Is Too Wide (Class I)	The sampling line is loose.	After turning off the AC/DC switch for 5 minutes, restart the inverter.
121	BMS Over Temperature Protect	1. The ambient temperature is too high. 2. Battery overloaded.	1. Check whether the ambient temperature of the battery is too high. 2. If the temperature is normal, let the battery rest for 30 minutes and restart it.
122	Short Circuit Protect	The positive and negative terminals of the battery are short-circuited.	Check whether the battery cable connections are correct.
123	Total voltage match failed	Contact technical personnel to troubleshoot the problem.	Contact technical support for further assistance.
124	The system is locked	Contact technical personnel to troubleshoot the problem.	Contact technical support for further assistance.
125	FUSE error protection	Contact technical personnel to troubleshoot the problem.	Contact technical support for further assistance.
126	Battery Port Voltage Abnormal Protection	The voltage on the battery charging port is too high.	Check whether the positive and negative battery power cables are connected to the correct ports.

## 10. Product specification

## 10.1. CH3-(75K-125K)-(T6,T8)-EU

Model	CH3-75K-T6-EU	CH3-80K-T6-EU	CH3-99.9K-T8-EU
<b>DC Input</b>			
Max. PV Array Power [kWp]@STC	150	160	200
Max. DC Voltage [V]	1250	1250	1250
MPPT Voltage Range [V]	300-1250	300-1250	300-1250
Rated DC Voltage [V]	1050	1050	1050
Start Voltage [V]	400	400	400
Max. DC Input Current [A]	40	40	40
Max. DC Short Circuit Current [A]	55	55	55
Number of Strings per MPPT	6*2	6*2	8*2
<b>Battery Parameters</b>			
Battery Type	LiFePO4		
Battery Voltage Range [V]	750-950		
Max. Charging / Discharging Current [A]	200		
<b>AC Output [On-grid]</b>			
Rated AC Power [kW]	75	80	99.9
Max. Apparent Power [kVA]	75	80	99.9
Rated Output Current [A]	108.3	115.5	144.2
Max. Output Current [A]	114.0	121.6	151.7
Rated AC Voltage/Range [V]	3L+N+PE, 220/380, 230/400		
Rated Output Frequency [Hz]	50 / 60		
Power Factor [cos $\phi$ ]	0i - 1 - 0c		
Total Harmonic Distortion [THDi]	< 3%		
<b>AC Input [On-grid]</b>			
Rated AC Voltage [V]	3L+N+PE, 220/380, 230/400		
Rated Output Frequency [Hz]	50 / 60		
Max. Input Current [A] (Backup enabled)	200	200	250
Max. Input Current [A] (Backup disabled)	114.0	121.6	151.7
<b>AC Output [Back-up]</b>			
Max. Output Power [kVA]	75	80	99.9
Peak Output Apparent Power [kVA]	1.1 times of rated power, continuous; 1.55 times of rated power, 1s		
Rated AC Voltage [kV]	3L+N+PE, 220/380, 230/400		
Rated Output Current [A]	108.3	115.5	144.2
Rated Output Frequency [Hz]	50 / 60		
Output THDv (@ Liner Load)	< 3%		
<b>AC Input [Generator]</b>			
Max. Input Power [kW]	75	80	99.9
Max. Input Current [A]	114.0	121.6	151.7
Rated Input Voltage [V]	3L+N+PE, 220/380, 230/400		
Rated Input Frequency [Hz]	50 / 60		
<b>Efficiency</b>			

Model	CH3-75K-T6-EU	CH3-80K-T6-EU	CH3-99.9K-T8-EU
Max. Efficiency	≥98%		
Euro Efficiency	≥97.5%		
Max. Battery to AC Efficiency	≥98%		
<b>Protection</b>			
PV Reverse Polarity Protection	Integrated		
Anti-islanding Protection	Integrated		
AC Overcurrent Protection	Integrated		
AC Short Circuit Protection	Integrated		
AC Overvoltage Protection	Integrated		
DC Switch	Integrated		
DC Surge Protection	II		
AC Surge Protection	II		
PV Terminal Temperature Detection	Integrated		
AFCI	Optional		
String-level Disconnect	Integrated		
<b>General Parameters</b>			
Communication	LED Indicators, WLAN, App		
Topology	Transformerless		
Operating Temperature Range	-30°C to +60°C (45°C to 60°C with derating)		
Cooling Method	Smart Air Cooling		
Ambient Humidity	5-95% (No condensing)		
Altitude [m]	3000		
Ingress Protection Rating	IP66		
Dimensions [H*W*D] [mm]	1076*894*394		
Weight [kg]	135		
Warranty [Year]	5/10		
Standard	IEC61727, IEC62116, IEC62109-1/-2, EN61000-6-2/-4		

Model	CH3-100K-T8-EU	CH3-110K-T8-EU	CH3-125K-T8-EU
<b>DC Input</b>			
Max. PV Array Power [kWp]@STC	200	220	250
Max. DC Voltage [V]	1250	1250	1250
MPPT Voltage Range [V]	300-1250	300-1250	300-1250
Rated DC Voltage [V]	1050	1050	1050
Start Voltage [V]	400	400	400
Max. DC Input Current [A]	40	40	40
Max. DC Short Circuit Current [A]	55	55	55
Number of Strings per MPPT	8*2	8*2	8*2
<b>Battery Parameters</b>			
Battery Type	LiFePO4		
Battery Voltage Range [V]	750-950		
Max. Charging / Discharging Current [A]	200		
<b>AC Output [On-grid]</b>			
Rated AC Power [kW]	100	110	125
Max. Apparent Power [kVA]	100	110	125
Rated Output Current [A]	144.3	158.7	180.4
Max. Output Current [A]	151.9	167.1	189.9
Rated AC Voltage/Range [V]	3L+N+PE, 220/380, 230/400		
Rated Output Frequency [Hz]	50 / 60		
Power Factor [cos $\phi$ ]	0i - 1 - 0c		
Total Harmonic Distortion [THDi]	< 3%		
<b>AC Input [On-grid]</b>			
Rated AC Voltage [V]	3L+N+PE, 220 / 380, 230 / 400		
Rated Output Frequency [Hz]	50 / 60		
Max. Input Current [A] (Backup enabled)	250	250	250
Max. Input Current [A] (Backup disabled)	151.9	167.1	189.9
<b>AC Output [Back-up]</b>			
Max. Output Power [kVA]	100	110	125
Peak Output Apparent Power [kVA]	1.1 times of rated power, continuous; 1.55 times of rated power, 1s		
Rated AC Voltage [kV]	3L+N+PE, 220/380, 230/400		
Rated Output Current [A]	144.3	158.7	180.4
Rated Output Frequency [Hz]	50 / 60		
Output THDv (@ Liner Load)	< 3%		
<b>AC Input [Generator]</b>			
Max. Input Power [kW]	100	110	125
Max. Input Current [A]	151.9	167.1	189.9
Rated Input Voltage [V]	3L+N+PE, 220/380, 230/400		
Rated Input Frequency [Hz]	50 / 60		
<b>Efficiency</b>			
Max. Efficiency	≥98%		
Euro Efficiency	≥97.5%		

Model	CH3-100K-T8-EU	CH3-110K-T8-EU	CH3-125K-T8-EU
Max. Battery to AC Efficiency	≥98%		
<b>Protection</b>			
PV Reverse Polarity Protection	Integrated		
Anti-islanding Protection	Integrated		
AC Overcurrent Protection	Integrated		
AC Short Circuit Protection	Integrated		
AC Overvoltage Protection	Integrated		
DC Switch	Integrated		
DC Surge Protection	II		
AC Surge Protection	II		
PV Terminal Temperature Detection	Integrated		
AFCI	Optional		
String-level Disconnecter	Integrated		
<b>General Parameters</b>			
Communication	LED Indicators, WLAN, App		
Topology	Transformerless		
Operating Temperature Range	-30°C to +60°C (45°C to 60°C with derating)		
Cooling Method	Smart Air Cooling		
Ambient Humidity	5-95% (No condensing)		
Altitude [m]	3000		
Ingress Protection Rating	IP66		
Dimensions [H*W*D] [mm]	1076*894*394		
Weight [kg]	135		
Warranty [Year]	5/10		
Standard	IEC61727, IEC62116, IEC62109-1/-2, EN61000-6-2/-4		

## 10.2. CH3-(75K-125K)-(T6,T8)-G-EU

Model	CH3-75K-T6-G-EU	CH3-80K-T6-G-EU	CH3-99.9K-T8-G-EU
<b>DC Input</b>			
Max. PV Array Power [kWp]@STC	150	160	200
Max. DC Voltage [V]	1250	1250	1250
MPPT Voltage Range [V]	300-1250	300-1250	300-1250
Rated DC Voltage [V]	1050	1050	1050
Start Voltage [V]	400	400	400
Max. DC Input Current [A]	40	40	40
Max. DC Short Circuit Current [A]	55	55	55
Number of Strings per MPPT	6*2	6*2	8*2
<b>Battery Parameters</b>			
Battery Type	LiFePO4		
Battery Voltage Range [V]	750-950		
Max. Charging / Discharging Current [A]	200		
<b>AC Output [On-grid]</b>			

Model	CH3-75K-T6-G-EU	CH3-80K-T6-G-EU	CH3-99.9K-T8-G-EU
Rated AC Power [kW]	75	80	99.9
Max. Apparent Power [kVA]	75	80	99.9
Rated Output Current [A]	108.3	115.5	144.2
Max. Output Current [A]	114.0	121.6	151.7
Rated AC Voltage/Range [V]	3L+N+PE, 220/380, 230/400		
Rated Output Frequency [Hz]	50 / 60		
Power Factor [cos $\phi$ ]	0i - 1 - 0c		
Total Harmonic Distortion [THDi]	< 3%		
<b>Efficiency</b>			
Max. Efficiency	≥98%		
Euro Efficiency	≥97.5%		
Max. Battery to AC Efficiency	≥98%		
<b>Protection</b>			
PV Reverse Polarity Protection	Integrated		
Anti-islanding Protection	Integrated		
AC Overcurrent Protection	Integrated		
AC Short Circuit Protection	Integrated		
AC Overvoltage Protection	Integrated		
DC Switch	Integrated		
DC Surge Protection	II		
AC Surge Protection	II		
PV Terminal Temperature Detection	Integrated		
AFCI	Optional		
String-level Disconnect	Integrated		
<b>General Parameters</b>			
Communication	LED Indicators, WLAN, App		
Topology	Transformerless		
Operating Temperature Range	-30°C to +60°C (45°C to 60°C with derating)		
Cooling Method	Smart Air Cooling		
Ambient Humidity	5-95% (No condensing)		
Altitude [m]	3000		
Ingress Protection Rating	IP66		
Dimensions [H*W*D] [mm]	1076*894*394		
Weight [kg]	127		
Warranty [Year]	5/10		
Standard	IEC61727, IEC62116, IEC62109-1/-2, EN61000-6-2/-4		

Model	CH3-100K-T8-G-EU	CH3-110K-T8-G-EU	CH3-125K-T8-G-EU
<b>DC Input</b>			
Max. PV Array Power [kWp]@STC	200	220	250
Max. DC Voltage [V]	1250	1250	1250
MPPT Voltage Range [V]	300-1250	300-1250	300-1250
Rated DC Voltage [V]	1050	1050	1050
Start Voltage [V]	400	400	400
Max. DC Input Current [A]	40	40	40
Max. DC Short Circuit Current [A]	55	55	55
Number of Strings per MPPT	8*2	8*2	8*2
<b>Battery Parameters</b>			
Battery Type	LiFePO4		
Battery Voltage Range [V]	750-950		
Max. Charging / Discharging Current [A]	200		
<b>AC Output [On-grid]</b>			
Rated AC Power [kW]	100	110	125
Max. Apparent Power [kVA]	100	110	125
Rated Output Current [A]	144.3	158.7	180.4
Max. Output Current [A]	151.9	167.1	189.9
Rated AC Voltage/Range [V]	3L+N+PE, 220/380, 230/400		
Rated Output Frequency [Hz]	50 / 60		
Power Factor [cos $\phi$ ]	0i - 1 - 0c		
Total Harmonic Distortion [THDi]	< 3%		
<b>Efficiency</b>			
Max. Efficiency	≥98%		
Euro Efficiency	≥97.5%		
Max. Battery to AC Efficiency	≥98%		
<b>Protection</b>			
PV Reverse Polarity Protection	Integrated		
Anti-islanding Protection	Integrated		
AC Overcurrent Protection	Integrated		
AC Short Circuit Protection	Integrated		
AC Overvoltage Protection	Integrated		
DC Switch	Integrated		
DC Surge Protection	II		
AC Surge Protection	II		
PV Terminal Temperature Detection	Integrated		
AFCI	Optional		
String-level Disconnect	Integrated		
<b>General Parameters</b>			
Communication	LED Indicators, WLAN, App		
Topology	Transformerless		
Operating Temperature Range	-30°C to +60°C (45°C to 60°C with derating)		
Cooling Method	Smart Air Cooling		

Model	CH3-100K-T8-G-EU	CH3-110K-T8-G-EU	CH3-125K-T8-G-EU
Ambient Humidity	5-95% (No condensing)		
Altitude [m]	3000		
Ingress Protection Rating	IP66		
Dimensions [H*W*D] [mm]	1076*894*394		
Weight [kg]	135		
Warranty [Year]	5/10		
Standard	IEC61727, IEC62116, IEC62109-1/-2, EN61000-6-2/-4		



**SJ** | 守护者

**GUANGZHOU SANJING ELECTRIC CO., LTD**

**Tel:** (86) 20 66608588 **Fax:** (86) 20 66608589 **Web:** [www.saj-electric.com](http://www.saj-electric.com)

**Add:** No.9, Lizhishan Road, Science City, Guangzhou High-tech Zone, Guangdong, P.R.China

©2025-2026 Guangzhou Sanjing Electric Co., Ltd. All rights reserved.