

**SAJI**

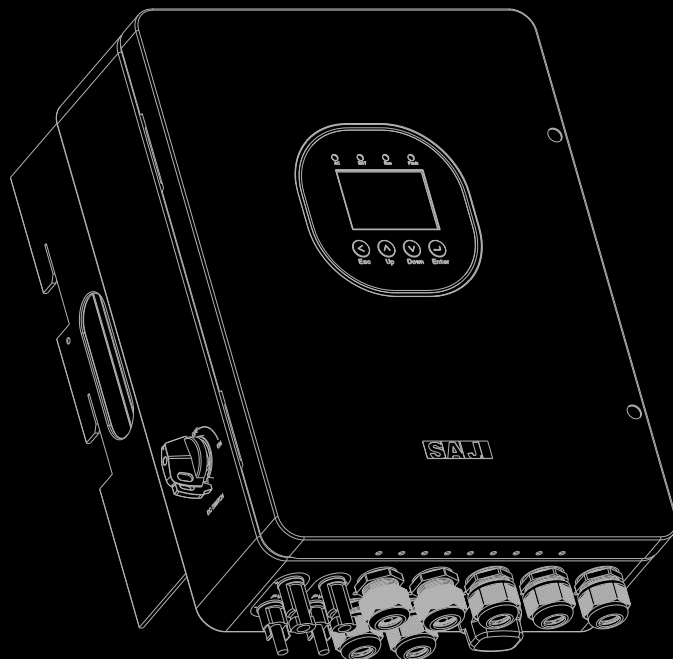

# H2 Series

**HYBRID INVERTER  
USER MANUAL**

H2-(3K-6K)-LS2-S

# Preface

Thank you for choosing SAJ products. We are pleased to provide you with first-class products and exceptional service.

This manual provides information about installation, operation, maintenance, troubleshooting and safety. Please follow the instructions of this manual so that we can ensure delivery of our professional guidance and whole-hearted service.

Customer-orientation is our forever commitment. We hope this document proves to be of great assistance in your journey for a cleaner and greener world.

We make constant improvements on the products and their documentation. This manual is subject to change without notice; these changes will be incorporated in new editions of the publication. To access the latest documentation, visit the SAJ website at <https://www.saj-electric.com/>.

Guangzhou Sanjing Electric Co., Ltd.



# TABLE OF CONTENTS

<b>1. SAFETY PRECAUTIONS.....</b>	<b>1</b>
1.1. About this document .....	2
1.1.1. Overview.....	2
1.1.2. Target audience.....	2
1.2. Safety.....	3
1.2.1. Safety levels.....	3
1.2.2. Safety symbols.....	3
1.2.3. Safety instructions.....	4
<b>2. PRODUCT INFORMATION.....</b>	<b>7</b>
2.1. General introduction .....	8
2.2. Model description .....	9
2.2.1. Product models .....	9
2.2.2. Model description.....	9
2.3. Dimension .....	9
2.4. Bottom view .....	10
2.5. Electrical terminals.....	11
2.6. LCD indicators.....	12
<b>3. TRANSPORTATION AND STORAGE.....</b>	<b>13</b>
3.1. Transportation.....	14
3.2. Storage.....	15
<b>4. INSTALLATION.....</b>	<b>17</b>
4.1. Precautions .....	18
4.2. Installation diagram.....	18
4.3. Choose installation site .....	20

4.3.1. Installation environment requirements .....	20
4.3.2. Installation position requirements .....	21
4.4. Prepare installation tools .....	22
4.5. Unpacking .....	23
4.5.1. Check the outer packing .....	23
4.5.2. Check the package contents .....	23
4.6. Install the inverter .....	25
4.7. Install the battery .....	28
<b>5. ELECTRICAL CONNECTION.....</b>	<b>29</b>
5.1. Safety instructions .....	30
5.2. System connection and recommended cable list.....	31
5.3. Connect the grounding cable .....	35
5.4. Open the junction box of the inverter .....	36
5.5. Connect the battery to the inverter.....	36
5.6. Assemble the AC-side electrical connection .....	39
5.7. Assemble the communication connection .....	42
5.7.1. Install the communication module.....	42
5.7.2. Connect the battery temperature sensor (for lead-acid batteries) .....	44
5.7.3. Connect the RJ45 ports .....	45
5.7.4. Connect the communication port .....	52
5.8. Assemble the PV-side electrical connection .....	54
5.9. Close the junction box of the inverter .....	57
<b>6. STARTUP AND SHUTDOWN.....</b>	<b>59</b>
6.1. Startup .....	60
6.2. Shutdown .....	60
6.3. Emergency shutdown .....	61
6.4. Restart after emergency shutdown .....	61
<b>7. COMMISSIONING ON THE APP.....</b>	<b>63</b>
7.1. Download the App .....	64
7.2. Log in to the App .....	64

---

7.3. Perform the initialization settings.....	66
7.4. Configure the communication module.....	74
7.5. Create a plant.....	75
7.6. View the fixed power factor mode and fixed reactive power mode .....	77
<b>8. COMMISSIONING ON THE LCD .....</b>	<b>79</b>
8.1. Operations on the main screen .....	80
8.2. Settings.....	81
8.2.1. Initialization setting .....	82
8.2.2. Battery setting .....	85
8.2.3. Advanced setting .....	86
8.2.4. Device setting .....	96
8.2.5. Equipment information .....	96
<b>9. Troubleshooting.....</b>	<b>97</b>
<b>10. Product specifications.....</b>	<b>109</b>
<b>11. Appendix.....</b>	<b>115</b>
11.1. Recycling and disposal .....	116
11.2. Warranty .....	116
11.3. Contacting support .....	116
11.4. Trademark .....	116

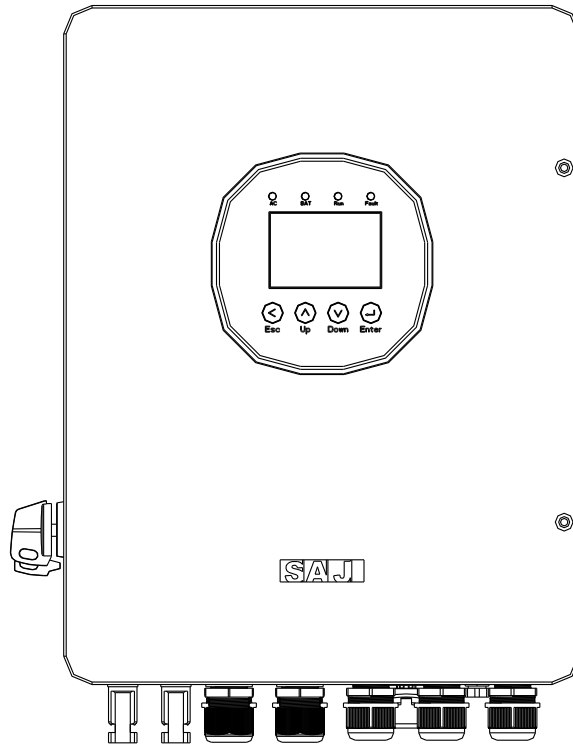

1.

**SAFETY  
PRECAUTIONS**



 **DANGER**

- Before installing, using, or maintaining this equipment, read the safety precautions thoroughly, and comply with them during operations.
- Failure to follow any of the instructions and warnings in this document may result in electrical shock, serious injury, or death, and may damage the equipment, potentially rendering it inoperable. SAJ shall not be held responsible for any personal injuries or property damage caused by improper use.

## 1.1. About this document

### 1.1.1. Overview

This user manual describes instructions and detailed procedures for installing, operating, maintaining, and troubleshooting the following SAJ inverters:

H2-3K-LS2-S

H2-3.6K-L2

H2-4K-LS2-S

H2-4.6K-LS2-S

H2-5K-LS2-S

H2-6K-LS2-S

Please read this manual carefully before installations and operations. Always keep this manual available in case of emergency and maintenance purposes.

### 1.1.2. Target audience

This manual is intended for qualified personnel who need to install, operate, maintain, and troubleshoot inverters and related system components. Qualified personnel should have the necessary training, knowledge, and experience in:

- Installing electrical equipment.
- Applying all applicable installation tools.
- Analyzing and reducing hazards involved in electrical work.
- Installing and configuring batteries.
- Selecting and using Personal Protective Equipment (PPE).

Battery service must only be performed or supervised by qualified personnel with knowledge of batteries and their required precautions.

## 1.2. Safety

### CAUTION

- Only qualified and trained electricians who have read and fully understood the safety regulations in this manual may install, maintain, or repair the equipment.
- Access to the equipment requires the use of a tool, lock, and key, or other security measures.

### 1.2.1. Safety levels

#### DANGER

DANGER indicates a hazardous situation which, if not avoided, will result in death or serious injury.

#### WARNING

WARNING indicates a hazardous situation which, if not avoided, will result in serious or moderate injury.



#### CAUTION









CAUTION indicates a hazardous situation which, if not avoided, will result in minor or moderate injury.

#### NOTICE

NOTICE indicates a situation which, if not avoided, will result in potential damage.

### 1.2.2. Safety symbols

Symbol	Description
	<b>DANGER: Electric Shock Hazard</b> This device is connected directly to the public grid. Failure to follow the warnings in this manual could result in severe electric shock.
	<b>DANGER: Hot Surface</b> The components inside the inverter battery will release a lot of heat during operation. Do not touch metal plate housing during operating.

	<b>WARNING: No Open Flames</b> Maintain a safe distance from all flammable and explosive materials.
	<b>CAUTION: Wait For 5 Minutes</b> Risk of electric shock from energy stored in capacitor. Do not remove cover until 5 minutes after disconnecting all sources of supply.
	<b>NOTICE: Keep Away from Children</b> Install the product out of reach of children.
	<b>NOTICE: Consult Manual Before Servicing</b> Check the user manual before servicing. If an error has occurred, refer to the troubleshooting chapter to remedy the error.
	<b>NOTICE: Dispose of Device Properly</b> This device shall NOT be disposed of in residential waste.
	<b>NOTICE: Dispose of Battery Properly</b> This battery module shall NOT be disposed of in residential waste.
	<b>CE mark</b> Equipment with the CE mark fulfills the requirements of the Low Voltage Directive (2014/35/EU) and Electro Magnetic Compatibility (2014/30/EU).
	<b>RoHS compliant mark</b> Equipment with the RoHS mark does not exceed the allowable amounts of the restricted substances defined in Restriction of Hazardous Substances in Electrical and Electronic Equipment.
	<b>Recyclable</b>

### 1.2.3. Safety instructions

For your safety, read all safety instructions before beginning any work, and ensure all procedures comply with local and national regulations.

 **DANGER**

- Risk of fatal personnel injuries due to electrical shock and high voltage.
- Do not touch the surface of the inverter while the housing is wet, otherwise, it might cause electrical shock.
- Do not touch the operating component of the inverter; it might result in burning or death.
- Do not stay close to the inverter while there are severe weather conditions including storms, lightning, etc.
- Before opening the housing, the inverter must be disconnected from the grid and PV array; wait for at least five minutes to let the energy storage capacitors completely discharge after disconnecting from power source.

 **WARNING**

- Do not touch non-insulated parts or cables.
- Do not short-circuit the positive (+) and negative (-) terminals.
- Disconnect the PV array from the inverter by using an external disconnecting device. If no external disconnection device is available, wait until no more DC power is applied to the inverter.
- Any unauthorized actions including modification of product functionality may cause lethal hazard to the operator, third parties, the units or their property. SAJ shall not be held responsible for the loss and these warranty claims.

 **NOTICE**

- Make sure the AC input voltage and current are compatible with the rated voltage and current of the inverter; otherwise, components might be damaged, or the device cannot work properly.
- Moving or reinstalling the inverter to another location might void the warranty without prior written permission from SAJ.

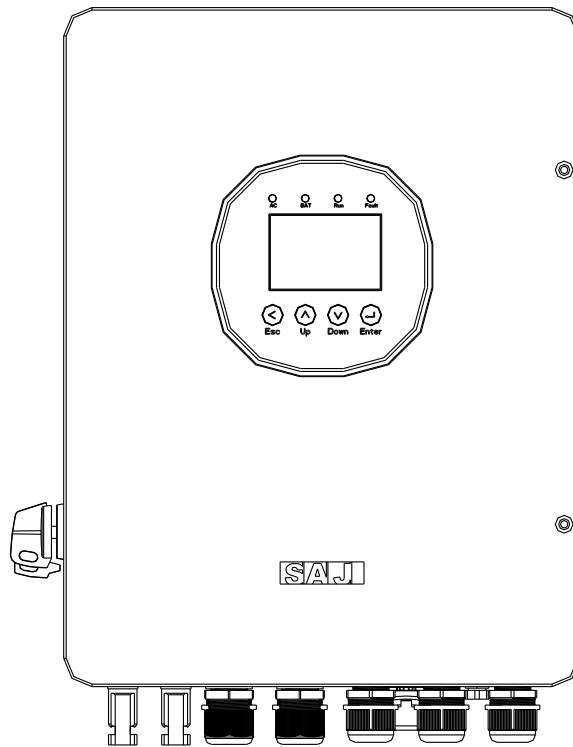

# 2.

## **PRODUCT INFORMATION**



## 2.1. General introduction

The H2 series is a transformer-less, low-voltage hybrid solar inverter and serves as a core component in energy storage systems. The H2 inverters provide the following features:

- The inverter integrates maximum power point tracking (MPPT), battery charging/discharging circuit and full-bridge inverting circuit.
- The inverter converts solar power to grid-compliant AC power for home loads and sells extra power to the grid. The solar power can also be stored into the battery for later use during grid failures or peak electricity price periods.
- When power outage occurs, the inverter seamlessly switches critical loads to battery power without supply interruption.
- The inverter offers three operating modes to suit different user needs and environments:
  - **Self-consumption Mode:** The basic working mode. Power generated by PV will be first supplied to the load, and then to the battery before exporting the remaining power to the grid.
  - **Time-of-use Mode:** This mode sets the charging and discharging periods of batteries according to the electricity price difference between peak and valley periods of the local grid.
  - **Back-up Mode:** Battery will be fully charged and will not be discharged until there is a mains error.

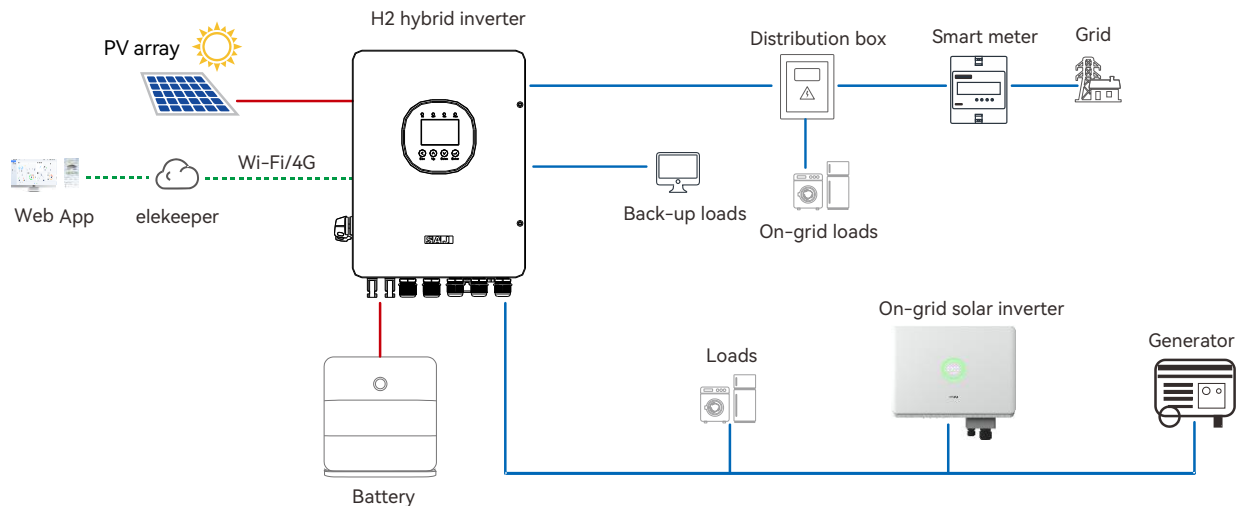

Figure 2.1 Application topology

## 2.2. Model description

### 2.2.1. Product models

The H2 series low-voltage single-phase inverter is available in the following models:

- H2-3K-LS2-S
- H2-4K-LS2-S
- H2-5K-LS2-S
- H2-3.6K-LS2-S
- H2-4.6K-LS2-S
- H2-6K-LS2-S

### 2.2.2. Model description

**H2** - **xK** - **LS2** - **S**

**H2:** Inverter series.

**xK:** Rated power of the inverter. For example, 3K indicates the rated power of the inverter is 3 kW.

**LS2:** Low-voltage, single-phase inverter with 2 MPPTs.

**S:** Features a smaller size compared to the H2-(5K-12K)-LS2 series inverter.

## 2.3. Dimension

Dimension (H x W x D): 460 x 350 x 231 mm (18.11 x 13.78 x 9.09 inches)

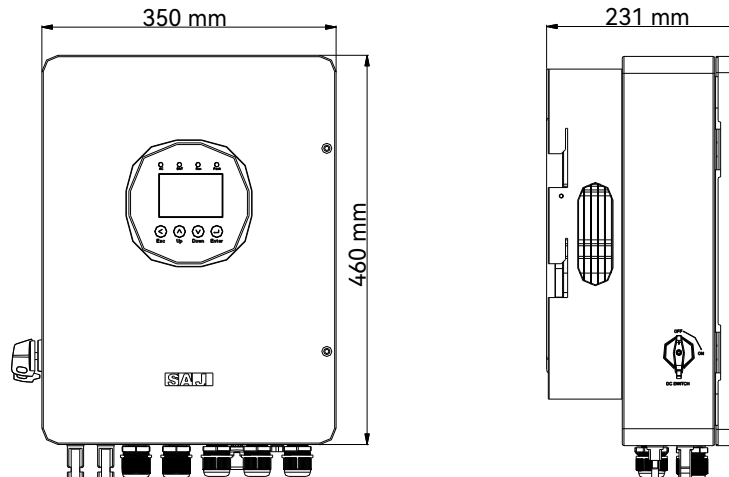

Figure 2.2 Inverter dimension

## 2.4. Bottom view

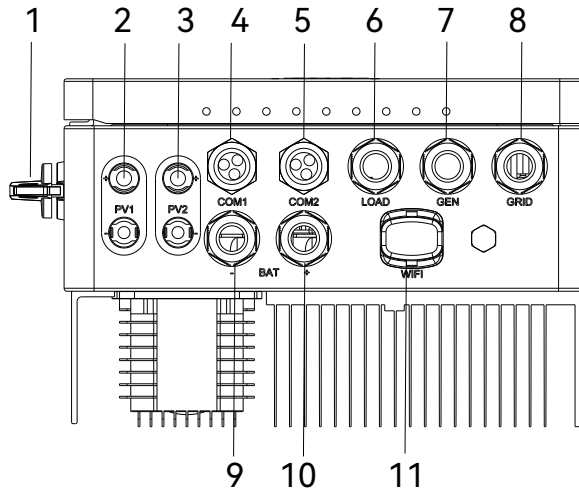

Figure 2.3 Bottom view of the inverter

Callout	Silkscreen	Description
1	DC Switch	DC switch which controls the PV connection.
2	PV 1+/1-	DC input terminals PV1+ and PV1-.
3	PV 2+/2-	DC input terminals PV2+ and PV2-.
4	COM1	Cable gland for communication cables connecting to communication port block A and RJ45 ports.
5	COM2	Cable gland for communication cables connecting to communication port block B.
6	LOAD	Cable gland for load cables connecting to terminals LOAD-L and LOAD-N.
7	GEN	Cable gland for generator cables connecting to terminals GEN-L and GEN-N.
8	GRID	Cable gland for grid cables connecting to terminals GRID-L and GRID-N.
9	BAT-	Cable gland for battery negative cable.
10	BAT+	Cable gland for battery positive cable.
11	WIFI	Wi-Fi port for connecting the communication module.

Table 2.1. Description of bottom-view silkscreen

## 2.5. Electrical terminals

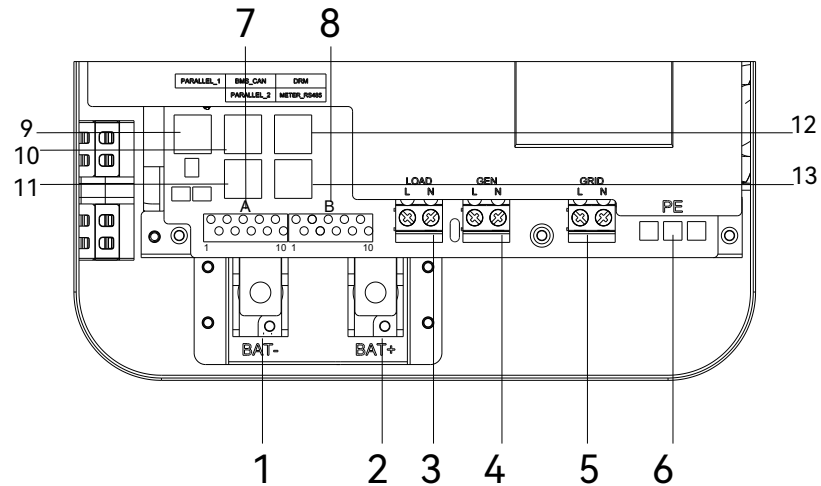

Figure 2.4 Electrical terminals in the junction box

Callout	Silkscreen	Description
1	BAT-	Terminals for connecting battery negative cables.
2	BAT+	Terminals for connecting battery positive cables.
3	LOAD-L, LOAD-N	Terminals for connecting to on-grid loads or back-up loads.
4	GEN-L, GEN-N	Terminals for connecting to generator.
5	GRID-L, GRID-N	Terminals for connecting to the grid.
6	PE	Terminals for connecting to protective earth.
7	Communication port block A	Ports for communication connection. Block A includes the following ports: MODBUS RS485 A / MODBUS RS485 B / MODBUS RS485 A / MODBUS RS485 B / MODBUS RS485 A1 / MODBUS RS485 B1 / CT1+ / CT1- / EX_SD+ / GND
8	Communication port block B	Ports for communication connection. Block B includes the following ports: GND / +12V_W / BAT_T+ / BAT_T- / DRY_GEN+ / G_S/ G / DRY_S / DRY / GND
9	PARALLEL_1	RJ45 port for parallel connection between inverters.
10	BMS_CAN	RJ45 port for communication connection to the battery control unit.
11	PARALLEL_2	RJ45 port for parallel connection between inverters.
12	DRM	RJ45 port for connecting to external control box. (in accordance with AS/NZS 4777.2 Demand Response Mode)
13	METR_RS485	RJ45 port for communication connection to the meter.

Table 2.2. Description of electrical terminals

## 2.6. LCD indicators

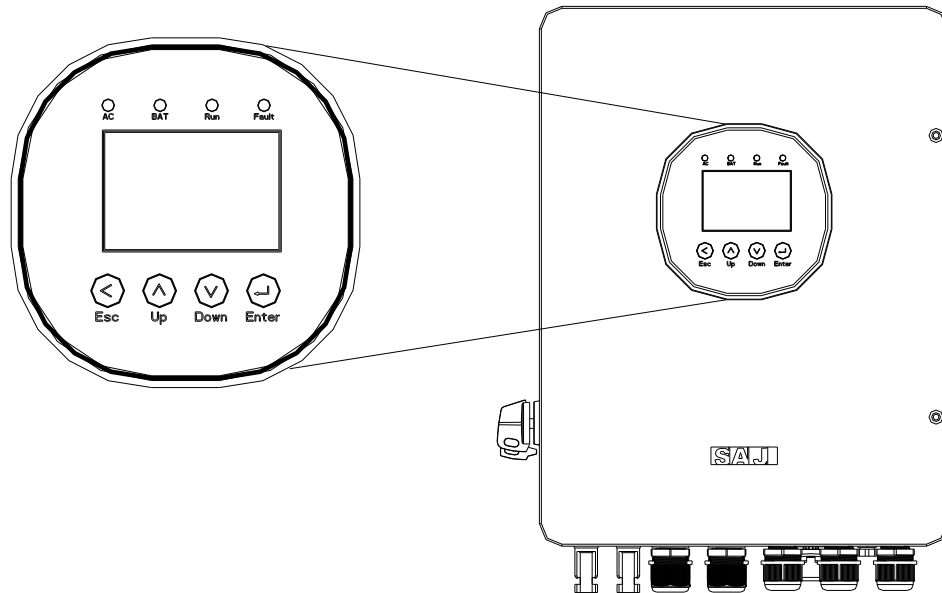

Figure 2.5 LCD indicators and buttons

LED indicator	Color	Status	Description
AC	Green	Solid on	The grid is connected and works properly.
BAT	Green	Solid on	The battery is working properly.
RUN	Green	Solid on	The inverter is working properly.
FAULT	Red	Solid on	The inverter is not working properly.

Table 2.3. Description of the LCD indicators

Button	Description
Esc	Exit the current operation.
Up	Scroll the screen up one line.
Down	Scroll the screen down one line.
Enter	Open the settings for the selected item.

Table 2.4. Description of the LCD buttons

# 3.

## **TRANSPORTATION AND STORAGE**



## 3.1. Transportation

### WARNING

- Do not drill holes into the product or its housing for any transportation-related purpose. Such modifications can damage the structural integrity and functionality of the device.
- Do not stack more than four cartons of inverters in a single pile.
- Ensure that transport vehicles are not overloaded and that weight is distributed evenly.
- Maintain stable driving conditions throughout transportation — avoid sudden acceleration, deceleration, or severe shaking.
- The weight of the inverter adheres to local regulations regarding manual handling requirements. Assign sufficient personnel for moving operations to avoid injury.
- Wear suitable protective gloves when manually handling equipment.
- When lifting the inverter, grip it firmly at the designated handles and support the base. Keep the unit level to avoid dropping.
- Use professional lifting and handling equipment operated by trained personnel with relevant skills and experience.

### NOTICE

- The transportation service provider must be certified for handling and transporting inverters.
- All transportation equipment must be adequately prepared and inspected by authorized professional organizations to verify compliance and suitability.
- Inverters must be placed in their original packaging or specially designed transport packaging.
- Packaging materials should possess sufficient strength and cushioning properties to prevent damage from impact or compression during transportation.
- Securely fasten inverters within the packaging to prevent movement during transportation. For larger or heavier units, use additional restraints or fixing devices as necessary.
- Observe all safety symbols displayed on the packaging prior to and during transportation.

## 3.2. Storage

### **WARNING**

- Do not unpack the inverter if it is not used immediately.
- Do not store the inverter in areas exposed to direct sunlight, rain, strong electric fields, or high humidity. Such conditions can cause overheating, electrical failure, or corrosion.
- Do not store inverters near chemically corrosive substances or in locations prone to pests or rodents. These can cause irreversible damage to housing and internal components.
- Do not stack more than four cartons of inverters in a single pile. Improper stacking may result in personal injury or device damage.
- Do not place heavy objects on top of the inverters. Crushing may deform the housing or damage internal components.
- Do not tilt or invert the packaging. Maintain the upright orientation as indicated on the carton to prevent internal displacement or component stress.

### **NOTICE**

- The storage temperature must remain between  $-30^{\circ}\text{C}$  to  $+65^{\circ}\text{C}$  ( $-22^{\circ}\text{F}$  to  $+149^{\circ}\text{F}$ ), with relative humidity between 5% and 95% (non-condensing).
- Store inverters in a clean, dry, and well-ventilated area to avoid moisture buildup and overheating.
- Retain the original packaging with desiccants when storing inverters. Repackage properly if necessary.
- Regularly inspect stored inverters every three months. Check for environmental damage, pest intrusion, or packaging degradation.
- Promptly replace any packaging materials that have been damaged by insects or rodents.
- If an inverter has been stored for two years or longer, it must undergo inspection and functional testing by qualified personnel before being commissioned.

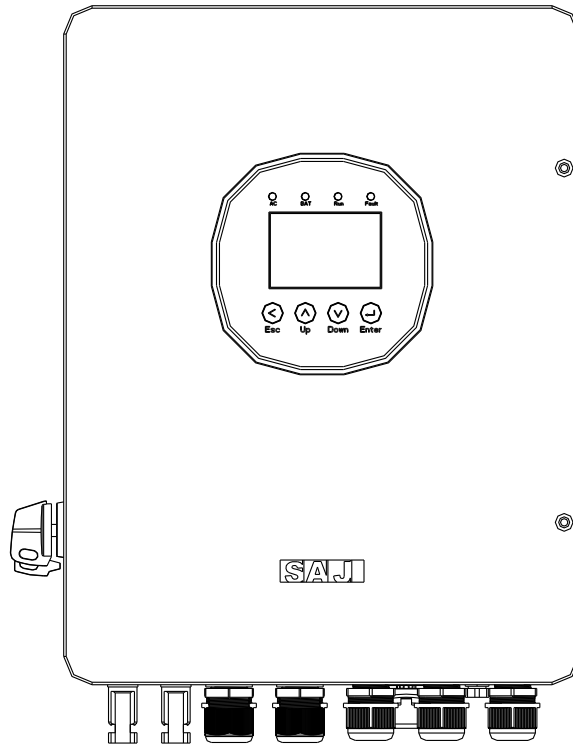

4.

# INSTALLATION



## 4.1. Precautions

For safety, read all safety instructions carefully before performing any work and comply with all applicable rules and regulations in the country or region where the product is installed.

### DANGER

- Risk of fatal electric shock or fire.
- Keep the inverter away from flammable and explosive materials.

### NOTICE

- Installation in unsuitable or non-compliant environments may reduce the inverter's service life.
- Avoid installing the inverter in direct, intense sunlight.
- Ensure the installation site is well-ventilated.

## 4.2. Installation diagram

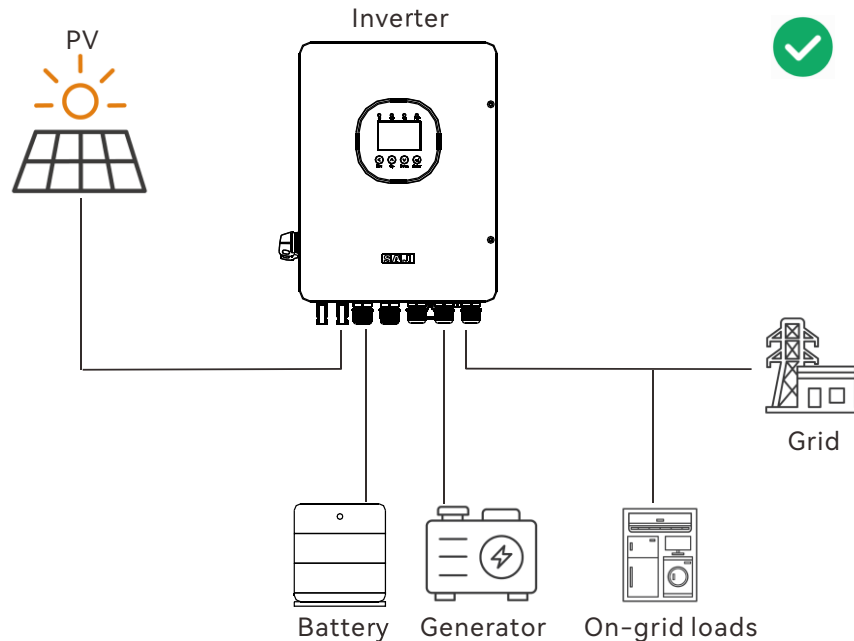
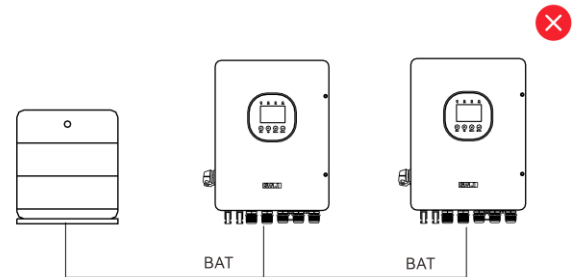
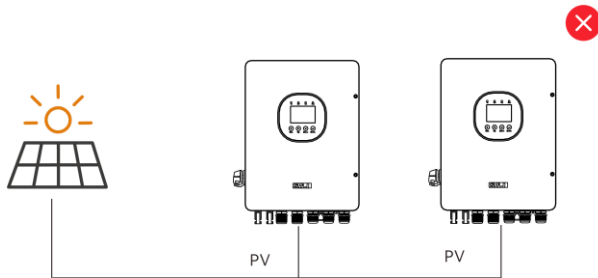

Figure 4.1. Applicable scenario

The following installation practices must be avoided. Any resulting damage will not be covered under warranty.

- Do not connect a single PV string to multiple inverters.
- Do not connect a single battery stack to multiple inverters.



- Do not connect the back-up side to any AC generator.
- Do not connect the back-up side to the grid.

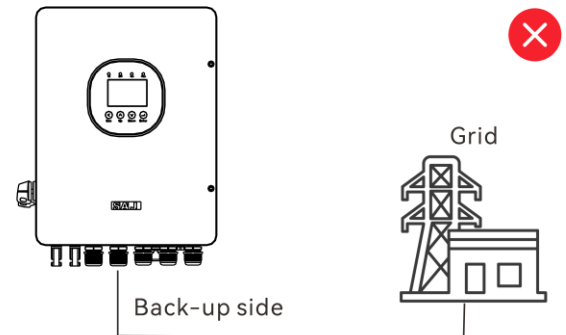
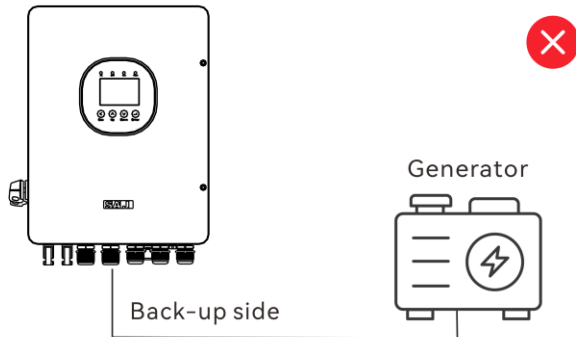

Figure 4.2. Non-applicable scenarios

## 4.3. Choose installation site

Read the following sections to carefully select a suitable installation site.

**Note:** safety regulations may differ across countries and regions. Always comply with all applicable local safety requirements.

### 4.3.1. Installation environment requirements

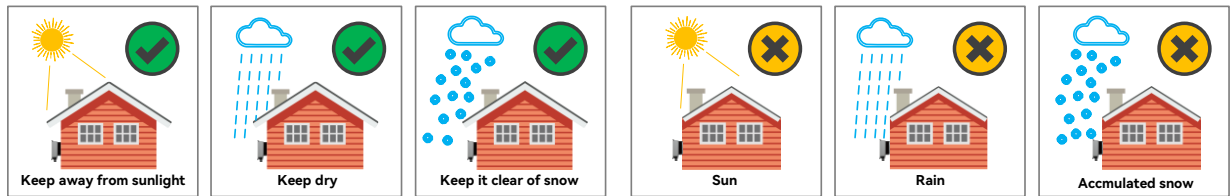

Figure 4.3. Installation location

- Do not expose the device to direct solar irradiation as this could cause power derating due to overheating.
- The installation environment must be free of inflammable or explosive materials.
- The device must be installed in a place away from heat sources.
- Do not install the device at a place where the temperature changes extremely.
- Keep the device away from children.
- Do not install the device in the bedroom, toilet, or bathroom.
- When installing the device at the garage, keep it away from the driveway.
- Keep the device from water sources such as taps, sewer pipes and sprinklers to prevent water seepage.
- It is recommended that the device be installed in an area where its status can be easily checked and maintained in case of failure or emergency.

### 4.3.2. Installation position requirements

- The device employs natural convection cooling, and it can be installed indoors or outdoors.
  - Indoor requirement  
The battery connected to the device cannot be installed in the habitable rooms.
  - Outdoor requirement  
Elevate the unit appropriately from the ground to avoid immersion in water.  
The exact height should be determined based on the conditions of the installation site.
- Install the device vertically. The maximum allowable backward-tilted angle is 15 degrees.
- Do not install it forward-tilted, horizontally or upside down.

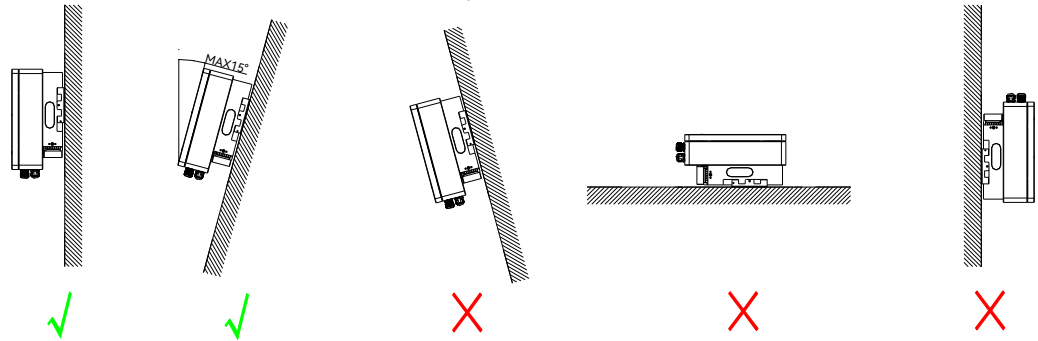

Figure 4.4. Installation position

- Select a solid and flat wall capable of supporting the total weight of the inverter and all associated accessories to ensure secure mounting.
- Maintain sufficient clearance around the inverter to allow for adequate airflow. This is especially important when installing multiple inverters in the same location.

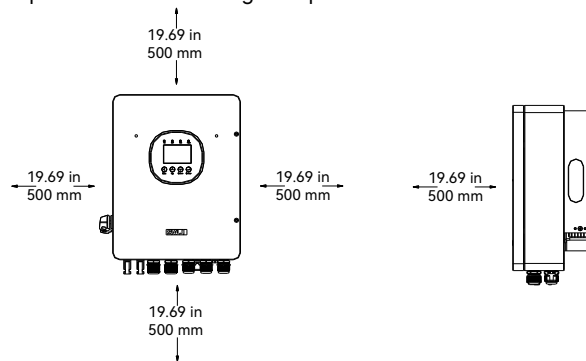

Figure 4.5. Installation clearance

## 4.4. Prepare installation tools

The installation tools below are for your reference. Tools include but are not limited to the following recommended ones. You may use other auxiliary tools based on site requirements.

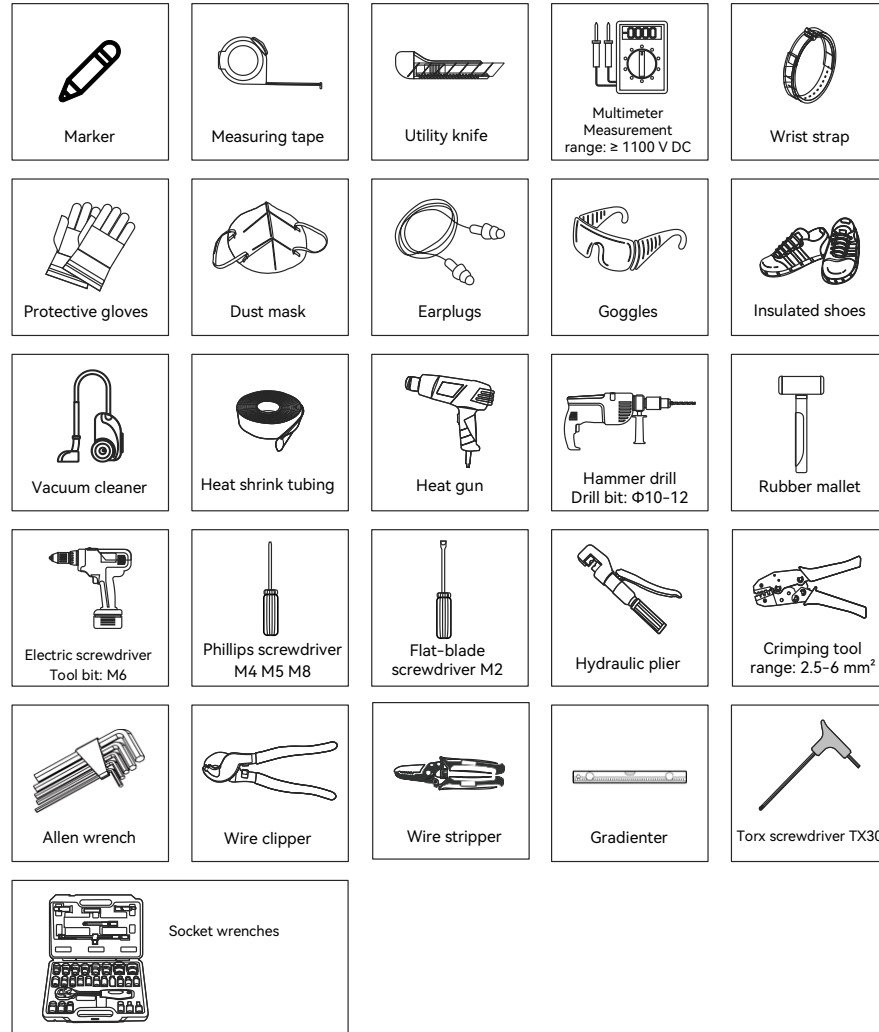

Figure 4.6. Suggested installation tools

## 4.5. Unpacking

### 4.5.1. Check the outer packing

Although all SAJ products undergo rigorous testing and inspection prior to shipment, damage may occasionally occur during transportation. Upon receipt, perform the following checks:

- Check the outer packaging for any damage, such as holes and cracks.
- Check equipment model matches your order.

If any serious damage is found or the model is not what you requested, do not unpack the product.

Please contact your dealer immediately.

### 4.5.2. Check the package contents

1. Verify that the shipment contains everything that you expected to receive. Contact after-sales if there are missing or damaged components.
2. Place the connectors separately after unpacking to avoid confusion for cable connection.

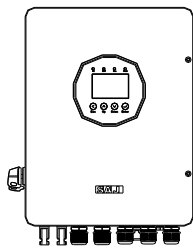

H2 inverter

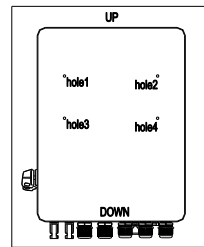

Hole positioning paper

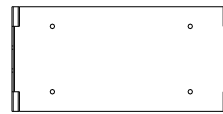

Wall mounting bracket

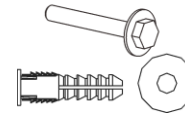

M6\*50 screw suite x4

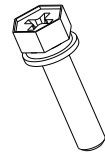

M4\*10 screw x2



Terminal lug x2



Current transformer

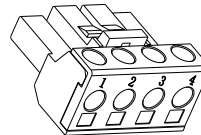

Terminal



Communication cable

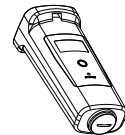

Communication module

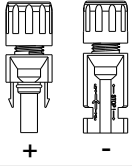

PV connectors x2



Documents

<sup>1</sup>The documents include a *Warranty Card* and a *Quick Guide*.

## 4.6. Install the inverter

### Before you start

Make sure that the wall is solid and flat enough to bear the weight of the inverter and accessories.

### Procedure

Step 1. Stick the hole positioning paper onto the wall. Drill four holes according to the instructions of four holes (hole1, hole2, hole3, and hole4). Then, remove the paper.

**Note:** Reserve enough distance at the bottom for cable connection.

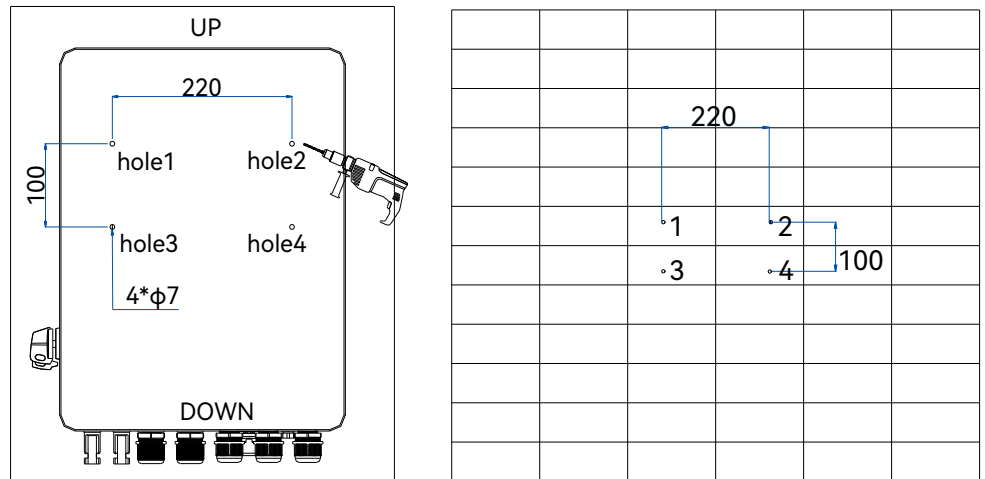

Figure 4.7. Drill four holes on the wall

Step 2. Install the mounting bracket onto the wall.

- ① Use a rubber mallet to insert four expansion tubes into the holes.
- ② Align the holes of the mounting bracket to the drilled holes in the wall.
- ③ Insert and tighten the screws into the drilled holes to fix the mounting bracket to the wall.

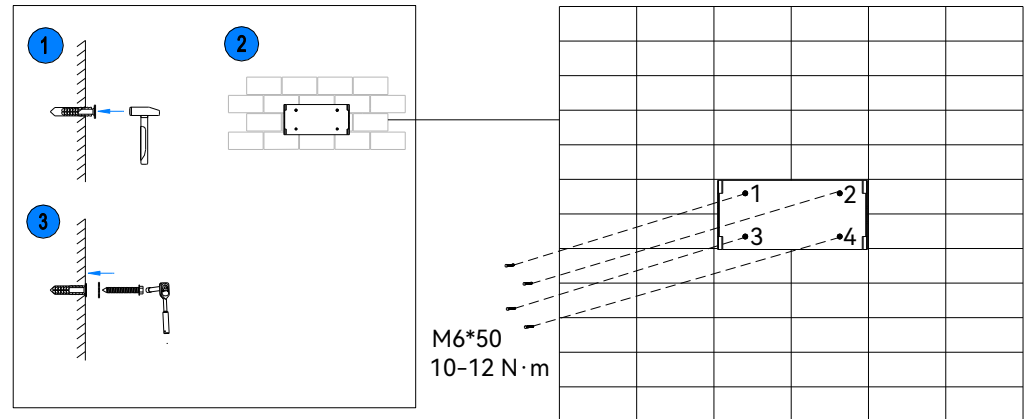

Figure 4.8. Install the mounting bracket onto the wall

Step 3. Mount the inverter onto the mounting bracket.

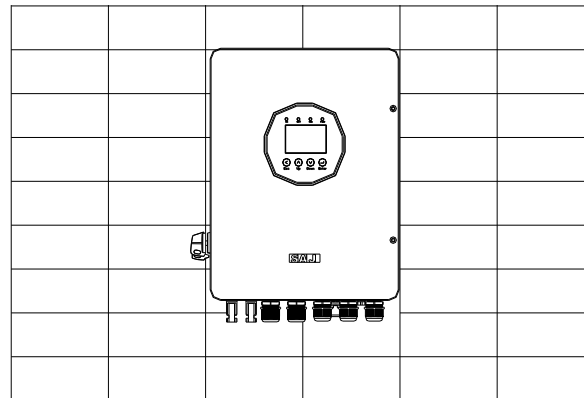

Figure 4.9. Mount the inverter onto the bracket

Step 4. Insert two M4\*10 screws on both sides of the inverter to secure it to the wall.

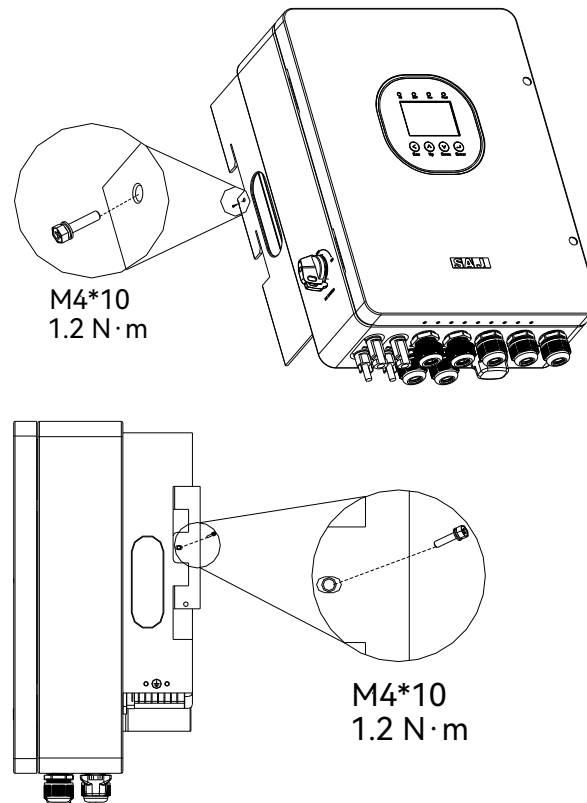

Figure 4.10. Secure the inverter

## 4.7. Install the battery

 **CAUTION**

- Do not connect the positive port (BAT+) to the negative port (BAT-) of the battery. This will short-circuit the battery and cause serious damage.

 **NOTICE**

- The H2 series inverter is only compatible with the batteries listed below. Using any other untested battery might cause damage to the inverter and thus void the inverter warranty.
- To comply with regulations, install a battery isolator  $\geq 70A$  near the inverter. This is not required when using the SAJ B2 battery model (B2-5.0-LV1 or B2-5.0-LV2), as it incorporates a built-in DC isolator within its low-voltage box unit.

The H2 series inverter is compatible with the following SAJ batteries. For details on installing the battery, refer to the corresponding battery *User Manual*.

Brand	Compatible battery models
SAJ	B2-5.0-LV1, B2-5.0-LV2, B3-5.0-LV

# 5.

## **ELECTRICAL CONNECTION**



## 5.1. Safety instructions

 **DANGER**

- Dangerous to life due to potential fire or electricity shock.
- Ensure that the equipment is powered off before performing any wiring operations.
- Do not install the inverter near any inflammable or explosive items.
- When powered on, the equipment should be in conformity with national rules and regulations.
- Operations must be operated by qualified technicians in accordance with local and national power grid standards and regulations.
- Technicians must be aware that the inverter is a bi-power supply equipment. Before connection, technicians must wear necessary protective equipment, including insulating gloves, insulating shoes, and a safety helmet.



Model	① DC breaker	② AC breaker for generator	③ AC breaker for backup loads	④ AC breaker for grid	⑤⑥ AC breaker for normal loads/smart meter	⑦ AC breaker for utility meter	⑧ RCD For grid	⑨⑩ RCD for normal and backup loads
H2-3K-LS2-S	100 A/60 V	20 A/230 V	20 A/230 V	20 A/230 V	Depending on loads and meter	Main breaker	300 mA RCD	30 mA RCD
H2-3.6K-LS2-S	125 A/60 V	20 A/230 V	20 A/230 V	20 A/230 V				
H2-4K-LS2-S	125 A/60 V	25 A/230 V	25 A/230 V	25 A/230 V				
H2-4.6K-LS2-S	160 A/60 V	25 A/230 V	25 A/230 V	25 A/230 V				
H2-5K-LS2-S	160 A/60 V	32 A/230 V	32 A/230V	32 A/230V				
H2-6K-LS2-S	180 A/60 V	40 A/230 V	40 A/230 V	40 A/230 V				

Cable (90°C, Copper)	Recommended cross-sectional area (mm <sup>2</sup> )						Stripping Length (mm)
	H2-3K-LS2-S	H2-3.6K-LS2-S	H2-4K-LS2-S	H2-4.6K-LS2-S	H2-5K-LS2-S	H2-6K-LS2-S	
Ground	4	6	6	6	6	6	15
PV	4	4	4	4	4	4	10
Battery	16	16	25	25	35	50	15
GEN	4	4	4	6	6	6	12
LOAD	4	4	4	6	6	6	12
GRID	4	4	4	6	6	6	12

- Whole home backup system connection

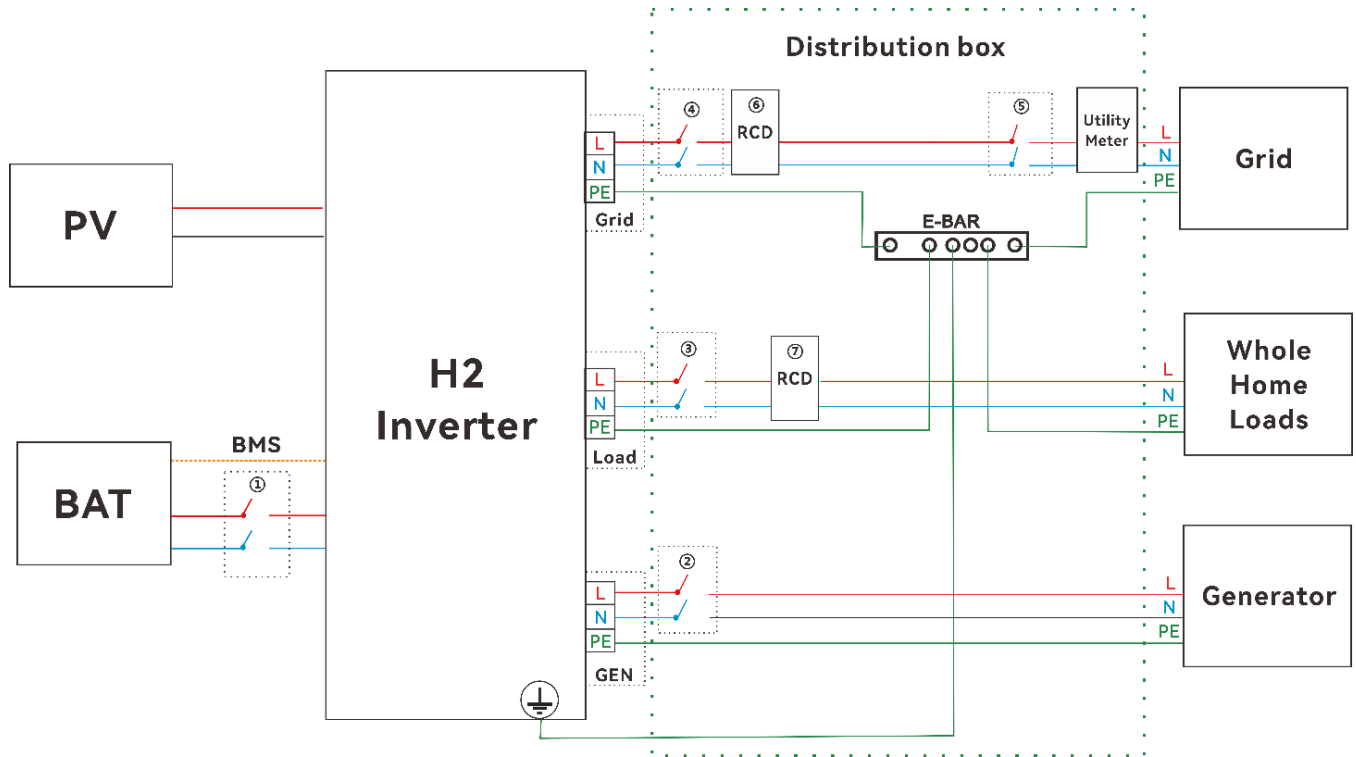

Figure 5.2. Whole home backup system connection diagram

Model	① DC breaker	② AC breaker for generator	③ AC breaker for whole home loads	④ AC breaker for grid	⑤ AC breaker for utility meter	⑥ RCD For grid	⑦ RCD for whole home loads
H2-3K-LS2-S	100 A/60 V	20 A/230 V	63 A/230V	63 A/230V	Main breaker	300 mA RCD	30 mA RCD
H2-3.6K-LS2-S	125 A/60 V	20 A/230 V	63 A/230V	63 A/230V			
H2-4K-LS2-S	125 A/60 V	25 A/230 V	63 A/230V	63 A/230V			
H2-4.6K-LS2-S	160 A/60 V	25 A/230 V	63 A/230V	63 A/230V			
H2-5K-LS2-S	160 A/60 V	32 A/230 V	63 A/230V	63 A/230V			
H2-6K-LS2-S	180 A/60 V	40 A/230 V	63 A/230V	63 A/230V			

Cable (Bypass) (90°C, Copper)	Recommended cross-sectional area (mm <sup>2</sup> )						Stripping Length (mm)
	H2-3K-LS2-S	H2-3.6K-LS2-S	H2-4K-LS2-S	H2-4.6K-LS2-S	H2-5K-LS2-S	H2-6K-LS2-S	
Ground	4	6	6	6	6	6	15
PV	4	4	4	4	4	4	10
Battery	16	16	25	25	35	50	15
GEN	4	4	4	6	6	6	12
LOAD	10	10	10	10	10	10	12
GRID	10	10	10	10	10	10	12

**Note:**

- Do not connect multiple inverters to one AC breaker.
- If the inverter is installed far away from the grid connection point, select a larger cable size to ensure that the voltage drops from the grid connection point to the inverter is within 2% of the grid voltage.

## 5.3. Connect the grounding cable



### NOTICE

The inverter cannot be used with functionally earthed PV Arrays.

#### About this task

- The grounding cable must be connected before other electrical connections.
- The cable needs to be prepared by the user.
- Choose appropriate cable according to the recommended cable list below or in **Section 5.2**. You may use other sizes based on real needs.

Cable (90°C, Copper)	Recommended cross-sectional area		Stripping length	Recommended torque
	H2-3K-LS2-S	H2-(3.6K-6K)-LS2-S		
Ground	4 mm <sup>2</sup>	6 mm <sup>2</sup>	15 mm / 0.59 inch	2 N·m / 17.70 LB-IN

#### Procedure

Step 1. Assemble the cable and OT/DT terminal.

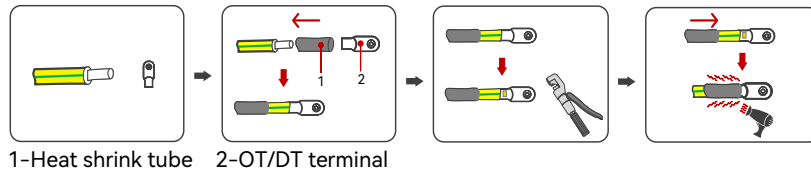

Figure 5.1. Prepare the grounding cable

Step 2. Remove the screw on the ground terminal and secure the cable.

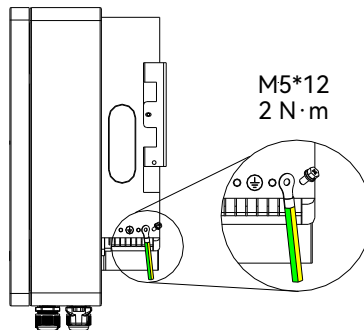

Figure 5.2. Connect the grounding cable

## 5.4. Open the junction box of the inverter

### Procedure

Step 1. Use an Allen Wrench to loosen the two screws on the cover to open the cover.

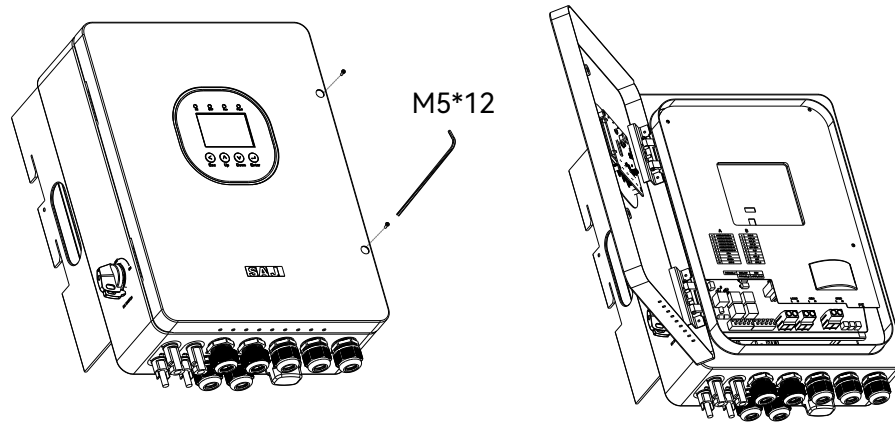

Figure 5.3. Open the junction box

## 5.5. Connect the battery to the inverter

### ⚠ WARNING

Before connecting the battery cables, ensure all the following requirements are met:

- A DC breaker must be installed between the inverter and the battery. Choose appropriate DC breaker according to the recommended cable list in **Section 5.2**. You may use other sizes based on real needs.
- Ensure that the DC breaker is in the OFF position.
- Before connection, use a multimeter to verify that the battery voltage measures 0 Vdc.
- Do not turn on the battery switch until all cables are properly connected.

### About this task

The H2 series inverter is compatible with the following SAJ batteries. For details, refer to the corresponding battery *User Manual*.

Brand	Compatible battery models
SAJ	B2-5.0-LV1, B2-5.0-LV2, B3-5.0-LV

### Note:

- For battery details, refer to the user manual of the corresponding battery model.
- The H2 series inverter is only compatible with the batteries listed above. Using any other untested battery might cause damage to the inverter and thus void the inverter warranty.
- Some utility companies or electrical regulations may require a battery isolator to be installed near the inverter. Choose a  $\geq 70\text{A}$  battery isolator for regulation compliance.

### Procedure

Step 1. Strip off the insulation on the positive and negative battery cable ends.

**Note:** Use double-insulated cables for safety.

Cable (90°C, Copper)	Recommended cross-sectional area		Stripping length	Recommended torque
BAT+ and BAT-	H2-3K-LS2-S	16 mm <sup>2</sup>	15 mm / 0.59 inch	4.5 N·m / 39.83 LB-IN
	H2-3.6K-LS2-S	16 mm <sup>2</sup>		
	H2-4K-LS2-S	25 mm <sup>2</sup>		
	H2-4.6K-LS2-S	25 mm <sup>2</sup>		
	H2-5K-LS2-S	35 mm <sup>2</sup>		
	H2-6K-LS2-S	50 mm <sup>2</sup>		

If needed, crimp an insulation terminal on the cable end shown as follows:

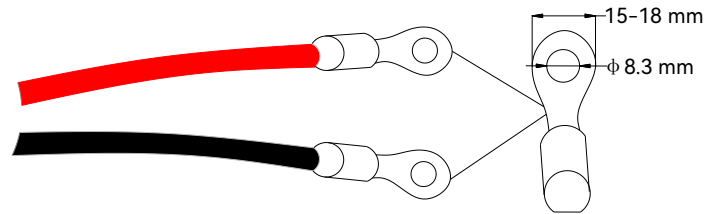

Figure 5.4. Crimp terminals on the cable ends

Step 2. Insert the cables through the cable glands **BAT -** and **BAT +**. Connect the cables to the battery terminal **BAT -** and **BAT +** in the junction box.

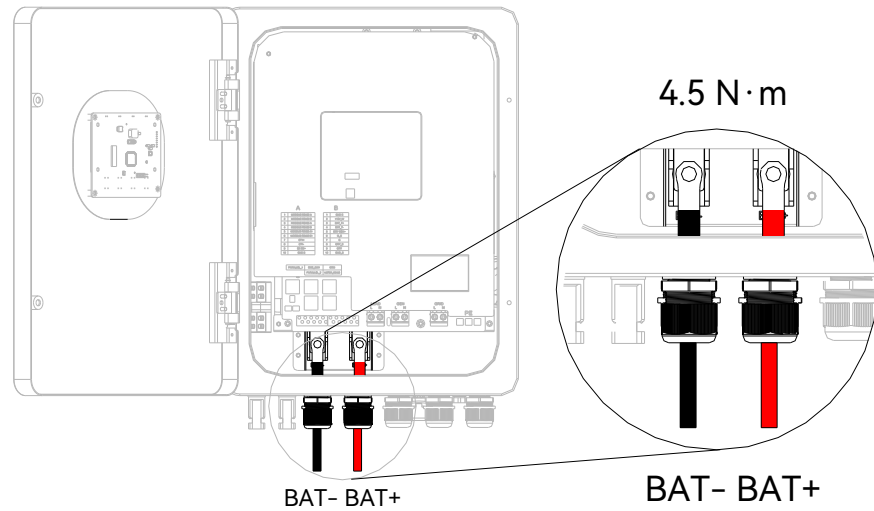

Figure 5.5. Connect the battery cables

## 5.6. Assemble the AC-side electrical connection



### WARNING

#### Risk of personal injury due to electric shock!

Before connecting the AC cables, ensure all the following requirements are met:

- An independent AC breaker must be installed on the output side of the inverter to ensure safe disconnection from the grid.
- Before connection, ensure that the AC breakers are in the OFF position.
- Multiple inverters cannot share one circuit breaker.
- Do not connect the load between the inverter and the circuit breaker.
- Before connection, ensure that the AC-side equipment is powered off.
- Ensure the rated power of the load does not exceed the rated output power of the inverter.
- Before connecting, use a multimeter to verify that the AC voltage measures 0 Vdc.
- Improper wiring of AC conductors will result in risks of electrical failure or equipment damage. Ensure that all connections are made correctly in accordance with the instructions in this document and in accordance with local wiring codes and regulations before applying power to the unit.



### NOTICE

- If the inverter is installed far away from the grid connection point, select a larger cable size to ensure that the voltage drops from the grid connection point to the inverter is within 2% of the grid voltage.

#### About this task

For safety and regulation compliance, AC breakers must be installed on the output side of the inverter. Choose appropriate AC breaker according to the recommended cable list in **Section 5.2**. You may use other sizes based on real needs

#### Procedure

Step 1. Strip the insulation on the GEN/LOAD/GRID cable ends.

**Note:** Use double-insulated cables for safety.



- Basic electrical connection

Cable (90°C, Copper)	Recommended cross-sectional area (mm <sup>2</sup> )		Stripping length	Recommended torque
	H2-(3K-4K)-LS2-S	H2-(4.6K-6K)-LS2-S		
GEN	4 mm <sup>2</sup>	6 mm <sup>2</sup>	12 mm / 0.47 inch	1 N·m / 8.85 LB-IN
LOAD	4 mm <sup>2</sup>	6 mm <sup>2</sup>		
GRID	4 mm <sup>2</sup>	6 mm <sup>2</sup>		

- Whole home backup connection

Cable (90°C, Copper)	Recommended cross-sectional area (mm <sup>2</sup> )		Stripping length	Recommended torque
	H2-(3K-4K)-LS2-S	H2-(4.6K-6K)-LS2-S		
GEN	4 mm <sup>2</sup>	6 mm <sup>2</sup>	12 mm / 0.47 inch	1 N·m / 8.85 LB-IN
LOAD	10 mm <sup>2</sup>			
GRID	10 mm <sup>2</sup>			

Table 5.1. Recommended cable specifications for GEN, LOAD and GRID

- Step 2. Insert the cables through the cable glands **GEN**, **LOAD**, and **GRID**. Connect the cables to the corresponding **L** and **N** terminals. Then, use 1 N·m torque to tighten the screws on the terminals to secure the cable connection.

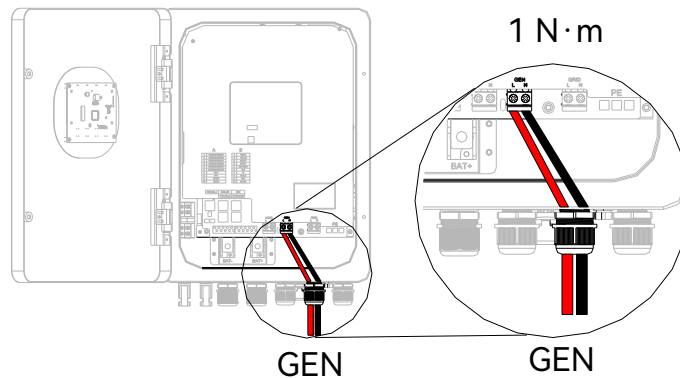

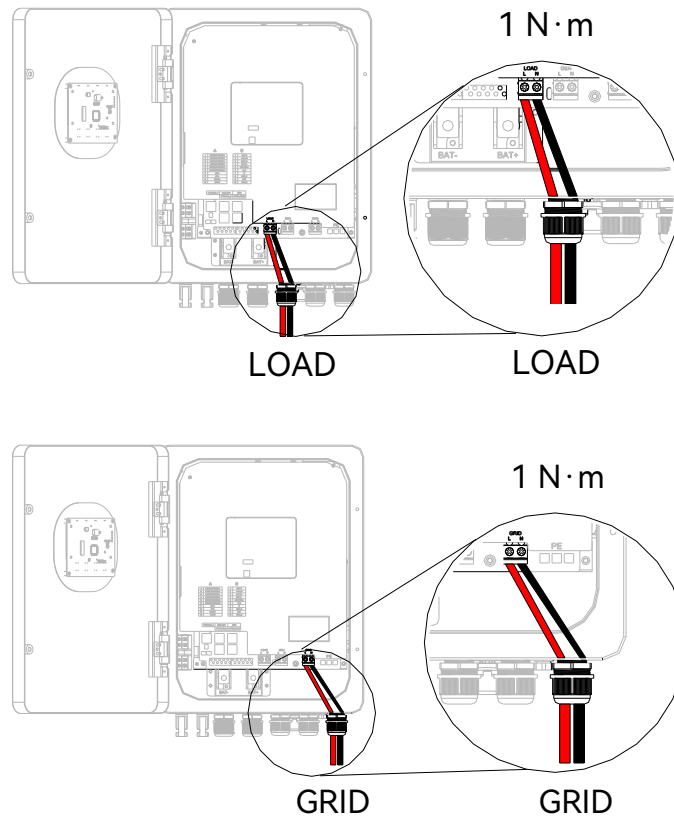

Figure 5.6. Connect the GEN, LOAD, and GRID cables

## 5.7. Assemble the communication connection

### 5.7.1. Install the communication module

#### About this task

An RS232 USB communication port is provided at the bottom of the junction box. This port is used to connect communication modules, such as a Wi-Fi module or an AIO3 module.

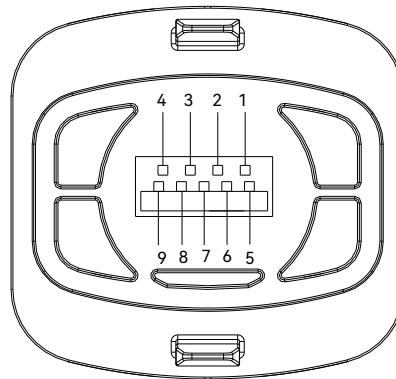

Pin	Description
1	GND: Ground wire
2	485A: 485 communication pin A
3	485B: 485 communication pin B
4	CANL: Low speed CAN signal
5	+5V: Power supply
6	232RX: Receive data
7	232TX: Transmit data
8	CANH: High speed CAN signal
9	NULL: Null

Table 5.2. Pin definitions

**Procedure**

Step 1. Remove the cover on the **WIFI** port.

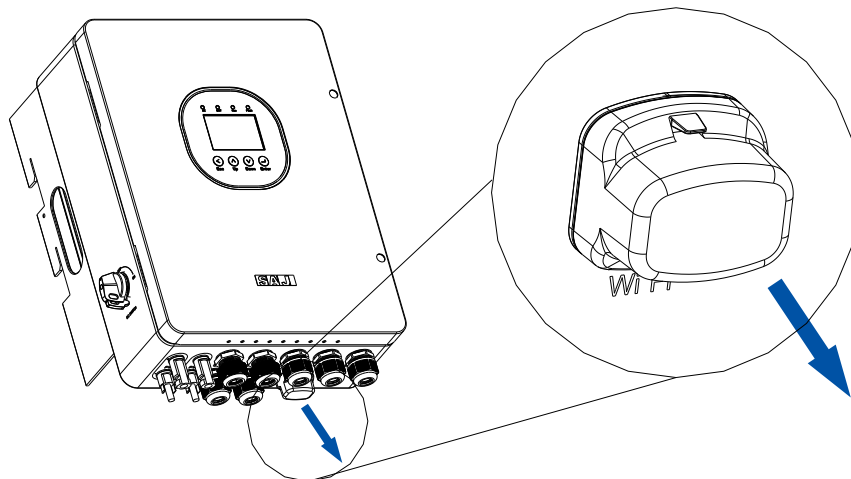

Figure 5.7. Removing the cover of the communication port

Step 2. Insert the communication module to the **WIFI** port and secure the module.

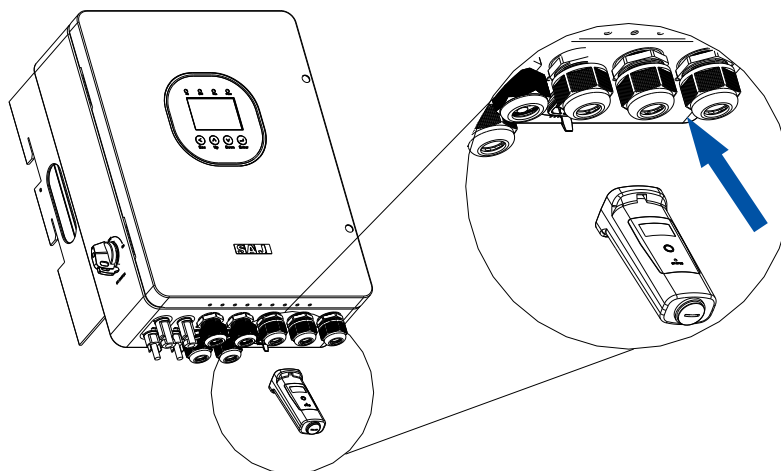

Figure 5.8. Connecting the communication module

## 5.7.2. Connect the battery temperature sensor (for lead-acid batteries)

### About this task

When lead-acid batteries are used, connect the battery temperature sensor from the battery to the inverter.

### Procedure

Step 1. Connect the battery temperature sensor to the battery.

Step 2. Insert the cable of the battery temperature sensor through **COM2** cable gland.

Then, connect the two wires to **BAT\_T+** and **BAT\_T-** on the communication port block **B**.

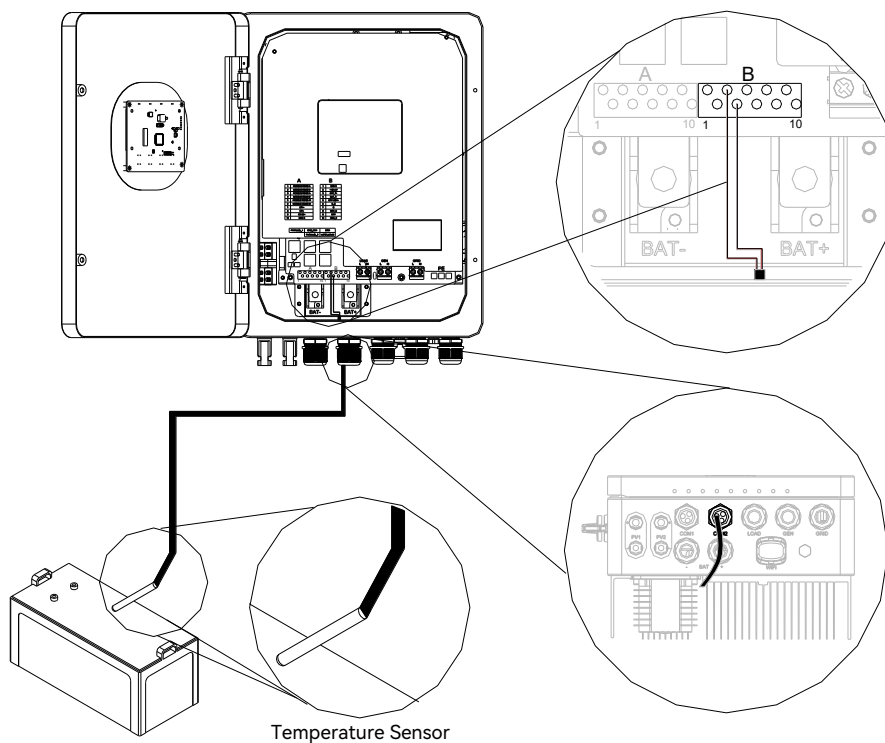

Figure 5.9. Connecting the battery temperature sensor

### 5.7.3. Connect the RJ45 ports

- Per your needs, prepare communication cables according to the pin definitions of RJ45 ports.

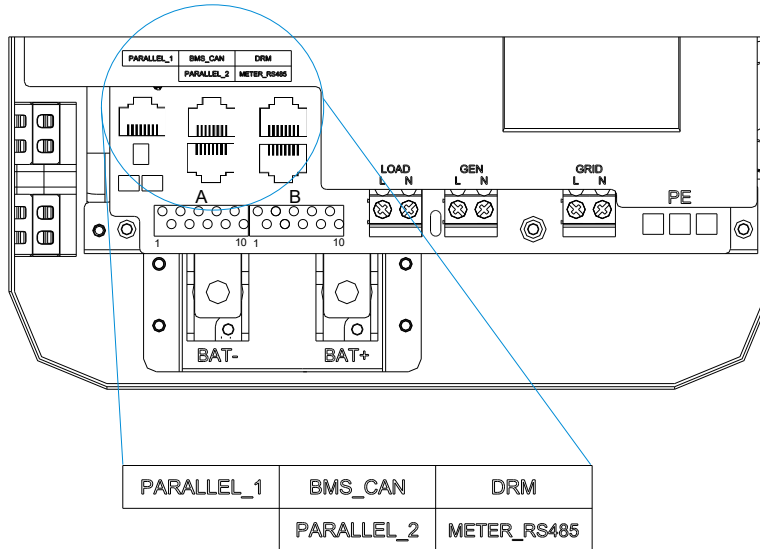
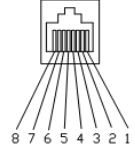

Figure 5.10. RJ45 ports

Port	Description
PARALLEL_1	Parallel connection is performed through the PARALLEL_1 and PARALLEL_2 ports. For detailed parallel connection methods, refer to <b>Section 5.7.3.2</b> “Parallel Connection” of the <i>User Manual</i> .
BMS_CAN	The inverter can communicate with the battery control unit through BMS_CAN port. For detailed connection methods, refer to <b>Section 5.7.3.3</b> “BMS_CAN connection” of the <i>User Manual</i> .
DRM	According to AS/NZS 4777.2, inverters must support the Demand Response Mode (DRM). With the use of external Demand Response Enabling Device (DRED), the inverter can adjust active and reactive power output to maintain grid stability and efficiency. For detailed connection methods, refer to <b>Section 5.7.3.1</b> “DRM connection” of the <i>User Manual</i> .
PARALLEL_2	Parallel connection is performed through the PARALLEL_1 and PARALLEL_2 ports. For detailed parallel connection methods, refer to <b>Section 5.7.3.2</b> “Parallel Connection” of the <i>User Manual</i> .
METER_RS485	The inverter can communicate with the meter through METER_RS485 port. For detailed connection methods, refer to <b>Section 5.7.3.4</b> “METER485 connection” of the <i>User Manual</i> .

Table 5.3. Description of RJ45 ports

PARALLRL_1		
1	CANH	
2	CANL	
3	BKUP TO GRID_BUS+	
4	CAN1_H	
5	CAN1_L	
6	CARRY_BUS+	
7	GRID TO BKUP_BUS+	
8	GND_S	

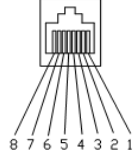

BMS_CAN		
1	NC	
2	NC	
3	NC	
4	CANH	
5	CANL	
6	NC	
7	NC	
8	NC	

DRM		
1	DRM 1/5	
2	DRM 2/6	
3	DRM 3/7	
4	DRM 4/8	
5	RefGen	
6	Com/DRM 0	
7	V+	
8	V-	

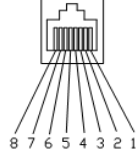
PARALLEL_2		
1	CANH	
2	CANL	
3	BKUP TO GRID_BUS+	
4	CAN1_H	
5	CAN1_L	
6	CARRY_BUS+	
7	GRID TO BKUP_BUS+	
8	GND_S	

METER_RS485		
1	RS485_B1	
2	RS485_A1	
3	GND_S	
4	RS485_B1	
5	RS485_A1	
6	GND_S	
7	RS485_B1	
8	RS485_A1	

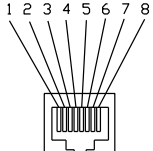
Table 5.4. Pin definition of RJ45 ports

- Strip the insulation of the communication cables with a wire stripper and separate the corresponding signal wires according to the pin definition.

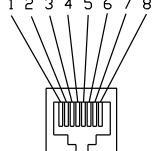
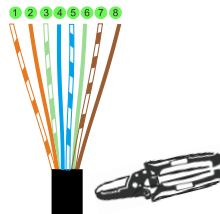

Figure 5.11. Stripping the communication cable

- Insert the cables through the cable glands **COM1** or **COM2** and connect the cables to the corresponding RJ45 ports.

### 5.7.3.1. DRM connection

In accordance with AS/NZS 4777.2, the inverter features a Demand Response Mode (DRM). When connected to an external control box, the inverter can quickly adjust its active or reactive power output and remains stable throughout the regulation process.

- **DRM pin description**

Pin	Description
DRM 1/5	DRM 1: Do not consume power. DRM 5: Do not generate power.
DRM 2/6	DRM 2: Do not consume more than 50% of rated power. DRM 6: Do not generate more than 50% of rated power.
DRM 3/7	DRM 3: Do not consume more than 75% of rated power and supply reactive power if capable. DRM 7: Do not generate more than 75% of rated power and absorb reactive power if capable.
DRM 4/8	DRM 4: Increase power consumption. DRM 8: Increase power generation.
RefGen	Accept analog voltage signals from the external control box to regulate the inverter's output power level.
Com/DRM 0	Com: Common reference for digital signals. DRM 0: Operate the disconnection device.
V+	For connecting to power supply, which provides operating power to the external control box.
V-	For connecting to power ground.

Table 5.5. DRM pin description

### 5.7.3.2. Parallel connection

The H2 series single-phase inverter supports parallel operation for up to 4 units in both on-grid and off-grid modes.

- **Communication connection for parallel operation**

Parallel connection is performed through the **PARALLEL\_1** and **PARALLEL\_2** ports.

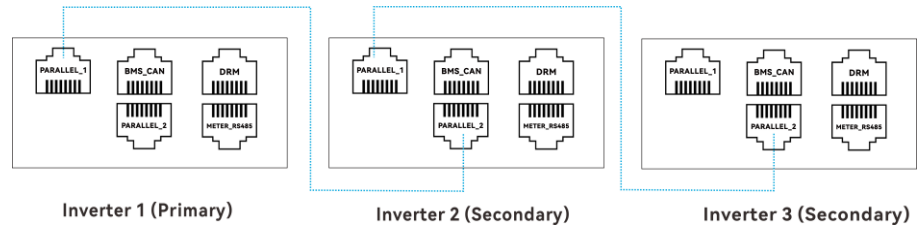

Figure 5.12. Communication connection for parallel operation

- **System connection for parallel operation**

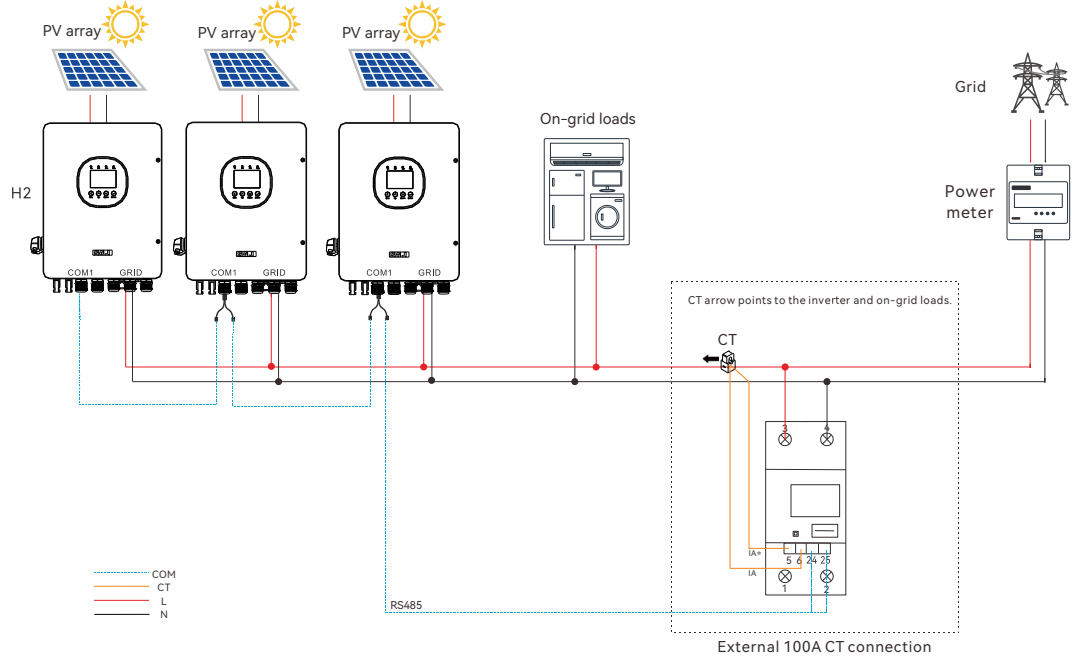

Figure 5.13. System connection for parallel operation

### 5.7.3.3. BMS connection

The inverter can communicate with the battery through the BMS ports. The Li-ion battery connection method is shown below.

**Note:** For lead-acid battery connection method, refer to **Section 5.7.2 Connect the battery temperature sensor (for lead-acid batteries)**.

- **Li-ion battery connection**

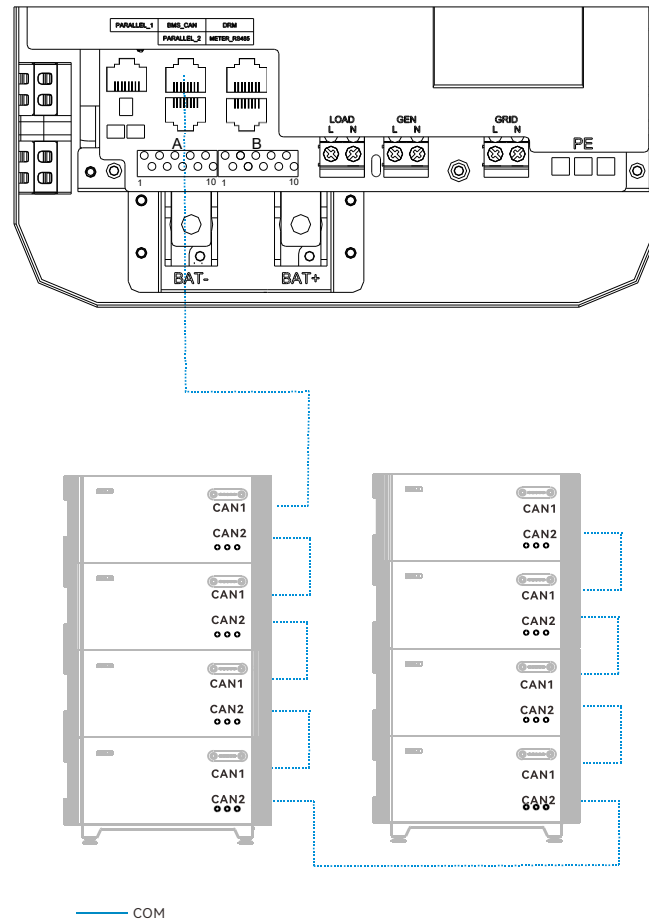

Figure 5.14. BMS connection

### 5.7.3.4. Smart meter connection

#### ! NOTICE

- Each inverter requires a dedicated smart meter.
- Each smart meter must be used with one CT. The CT should be installed at the same phase as the meter power cables.
- CT has a symbol of arrow indicating the correct installation orientation on the conductor. Verify this direction before installation.

The smart meter kit and CT in the package are necessary for system installation and are used to provide the operating condition of the inverter via RS485 communication. There are two schemes for users to choose, one is external CT connection with meter, the other is external CT connection without meter.

#### • External CT connection with meter

- Step 1. Connect meter's terminals 3,4 to Grid L, N respectively.
- Step 2. Clamp the CT to Grid L.
- Step 3. Connect the CT cable IA\* and IA to meter's CT terminal 5 and 6, respectively.
- Step 4. Connect the meter's terminals 24 and 25 to the inverter's **METER\_RS485** port.

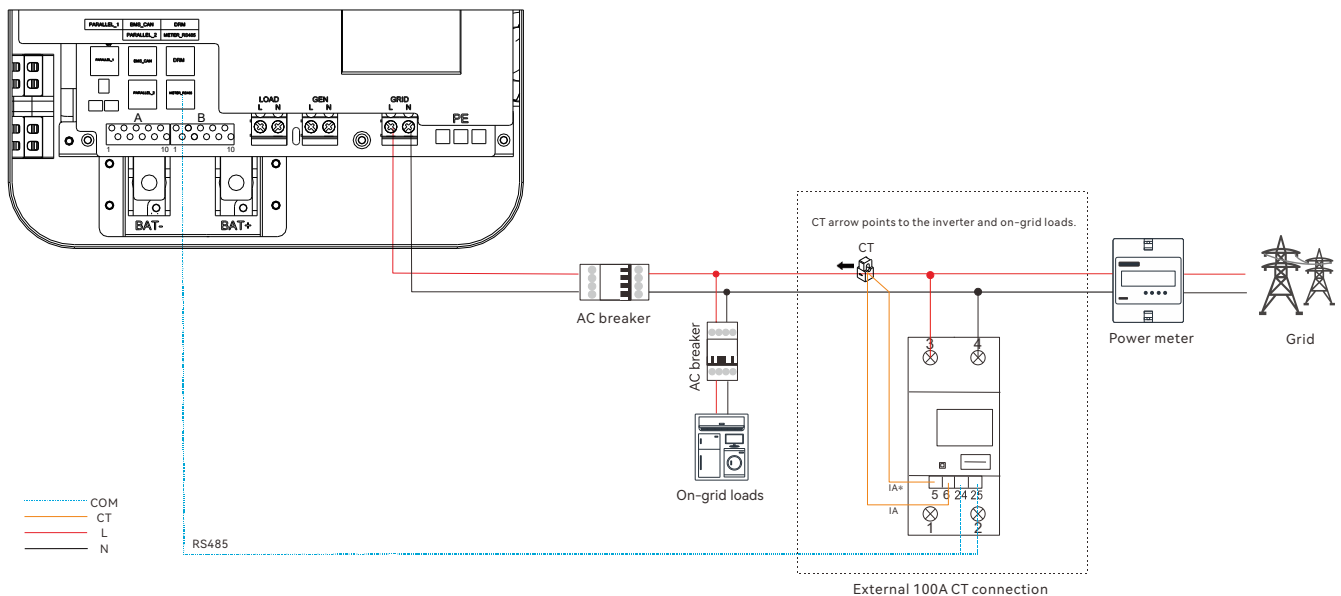

Figure 5.15. External CT connection with meter

- **External CT connection without meter**

Step 1. Clamp the CT to Grid L.

Step 2. Connect the CT to the inverter's CT communication port **CT1+** and **CT1-** of block A.

CT cable	Inverter's CT communication port
IA*	CT1+
IA	CT1-

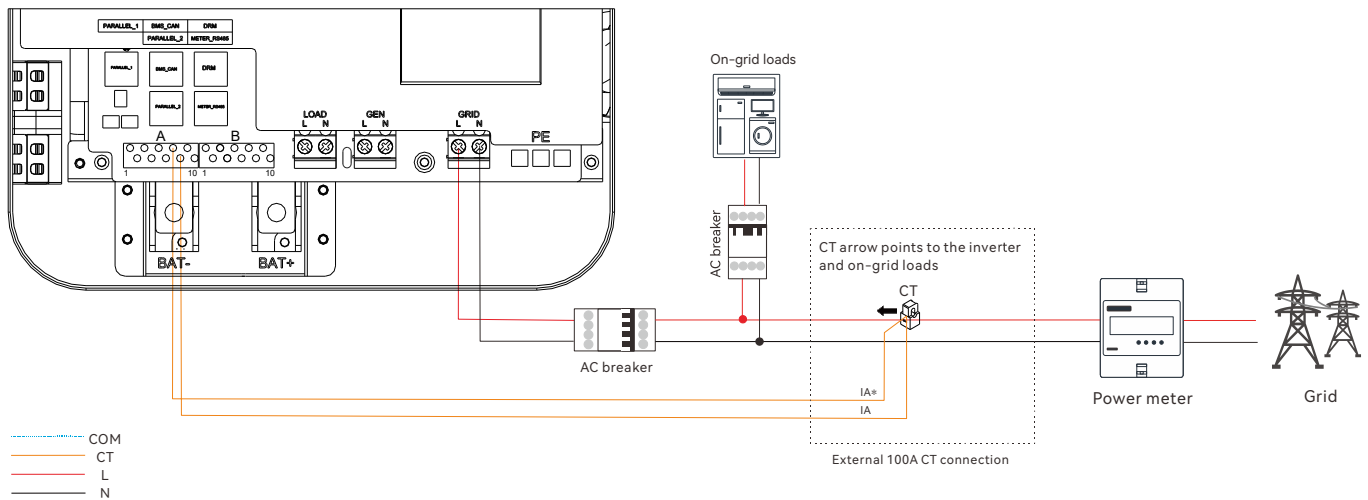
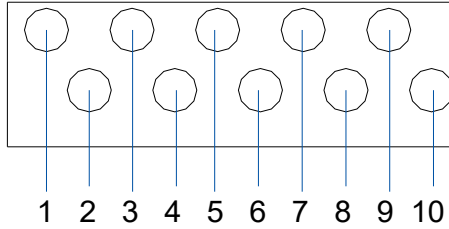

Figure 5.16. External CT connection without meter

### 5.7.4. Connect the communication port

- Per your needs, prepare communication cables according to the port description below.

Block A



Block B

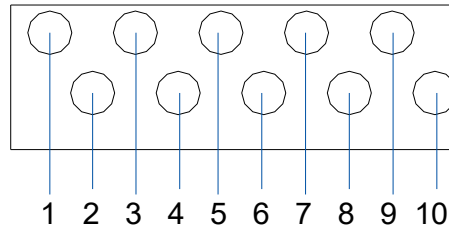

Block	Number	Port	Description
A	1	MODBUS RS485 A	Reserved daisy-chaining RS485 communication port for future use.
	2	MODBUS RS485 B	Reserved daisy-chaining RS485 communication port for future use.
	3	MODBUS RS485 A	Reserved daisy-chaining RS485 communication port for future use.
	4	MODBUS RS485 B	Reserved daisy-chaining RS485 communication port for future use.
	5	MODBUS RS485 A1	Reserved independent RS485 communication port for future use.
	6	MODBUS RS485 B1	Reserved independent RS485 communication port for future use.
	7	CT1+	For connecting CT positive cable.
	8	CT1-	For connecting CT negative cable.
	9	EX_SD+	For connecting to external emergency stop switch.
	10	GND	For connecting to external emergency stop switch.
B	1	GND	For connecting to 12V power ground.
	2	+12V_W	For connecting to 12V power supply.
	3	BAT_T+	For connecting the positive cable of the battery temperature sensor (only for lead-acid batteries).
	4	BAT_T-	For connecting the negative cable of the battery temperature sensor

			(only for lead-acid batteries).
	5	DRY_GEN+	For connecting to external generator dry contact.
	6	G_S	For connecting to external generator dry contact.
	7	G	Reserved dry contact.
	8	DRY_S	Reserved dry contact.
	9	DRY	Reserved protective earth.
	10	GND	Reserved protective earth.

Table 5.6. Description of communications port block

2. Insert the cables through the cable glands **COM1** or **COM2** and connect the cables to the corresponding ports.

Communication port	Through (Cable gland on the inverter)
Block A	COM1
Block B	COM2

Table 5.7. Connecting to communication port block

## 5.8. Assemble the PV-side electrical connection

Step 1. Prepare the PV cables according to the following specification.

Cable	Recommended cross-sectional area (mm <sup>2</sup> )
PV+ and PV-	4

Table 5.8. Recommended cable specification for PV

Step 2. Loosen the lock screws on positive and negative connectors.

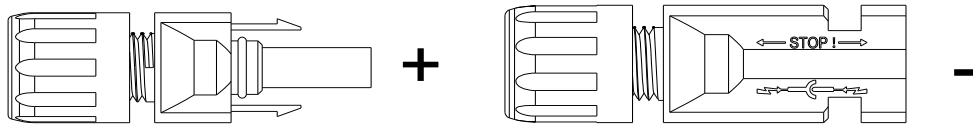

Figure 5.17. Loosening the lock screws on connectors

Step 3. Strip off the insulation of the positive and negative cables by 8–10 mm (0.31–0.39 inch).

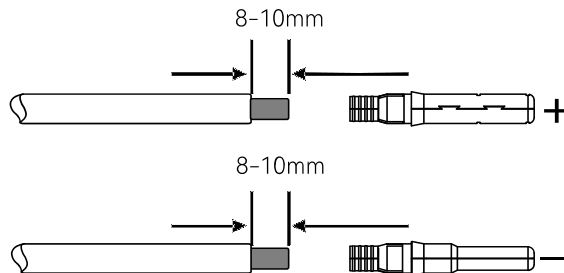

Figure 5.18. Stripping off the cable insulation

Step 4. insert the cable ends into the sleeves. Use a crimping plier to assemble the cable ends.

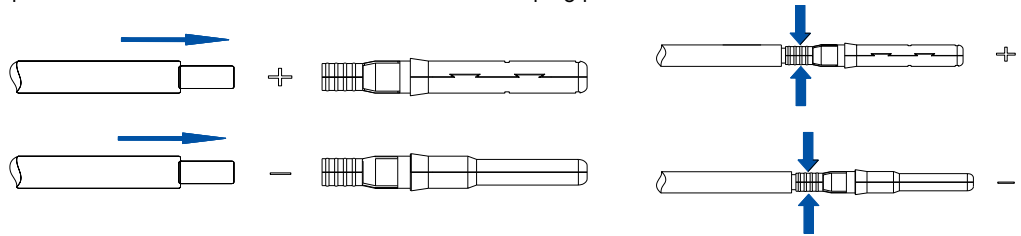

Figure 5.19. Assembling the cable ends

Step 5. Insert the assembled cable ends into the positive and negative PV connectors. Gently pull the cables backwards to ensure firm connection.

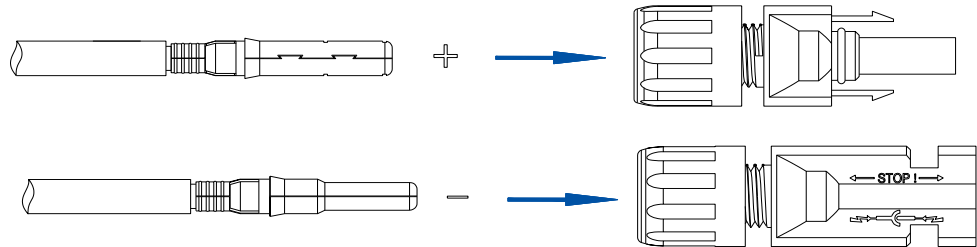

Figure 5.20. Inserting the assembled cables into connectors

Step 6. Tighten the lock screws on the positive and negative cable connectors.

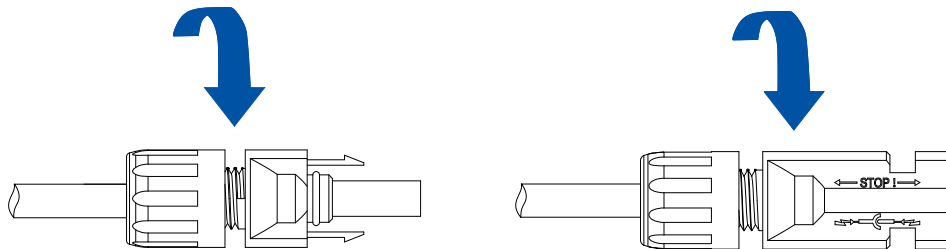

Figure 5.21. Tightening the lock screws on connectors

Step 7. Make sure that the DC switch is at the OFF position.

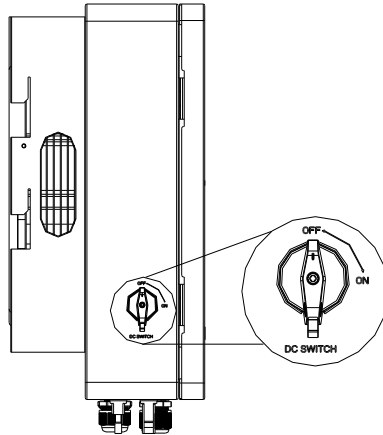

Figure 5.22. Turning OFF the DC switch

Step 8. Connect the positive and negative connectors into the positive and negative DC input terminals of the inverter. A “click” sound should be heard when the contact cable assembly is seated correctly.

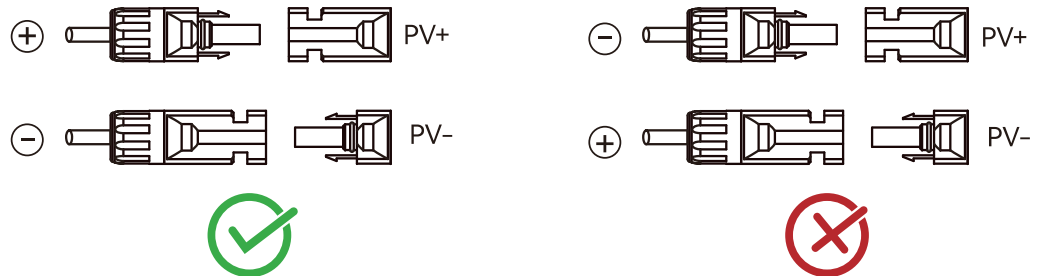

Figure 5.23. Connecting the connectors into terminals

## 5.9. Close the junction box of the inverter

Step 1. Install the cover back to the inverter and tighten the screws.

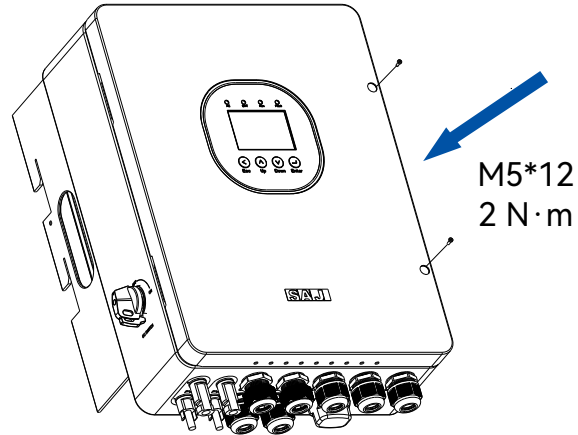
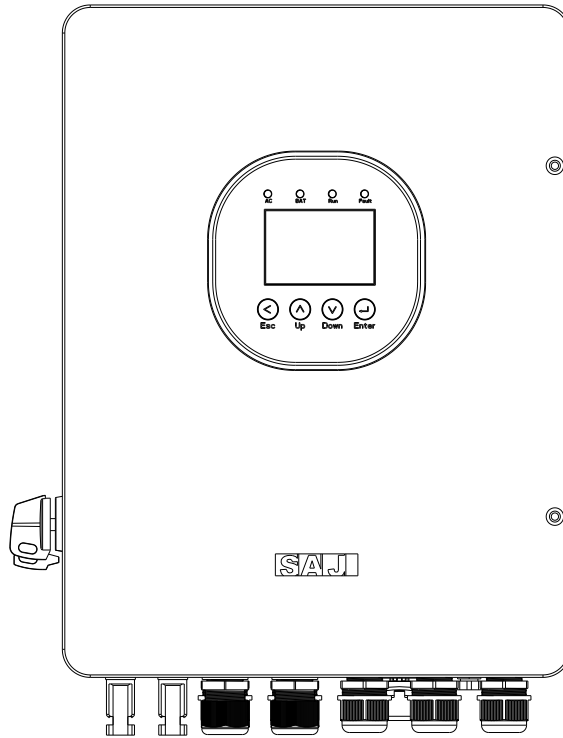

Figure 5.24. Closing the cover of the junction box



6.

**STARTUP AND  
SHUTDOWN**



## 6.1. Startup

Step 1. Open the junction box. Turn on the following breakers by pushing their handles upwards:

- a. Load breaker (optional, only when loads are connected)
- b. Battery breaker

Step 2. Turn on the breaker on the grid side.

Step 3. Turn on the DC switch on the left side of the inverter to establish the connection to the PV array.

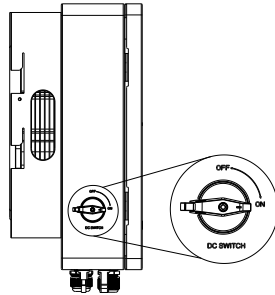

Figure 6.1. DC switch on the left side of the inverter

Step 4. Turn on the battery switch on the battery. For details, refer to the battery user manual.

Step 5. Press the START button on the left side of the inverter to enable the AC side.

Step 6. Check the LED indicator status on the inverter panel to verify that the inverter is operating properly. For details, refer to *section 2.6 "LCD indicators"*.

## 6.2. Shutdown

Step 1. To disable the AC side, press the START button on the left side of the inverter until it releases and returns to its out position.

Step 2. To disable the connection to PV array, turn off DC switch on the left side of the inverter.

Step 3. To disable the connection to battery, turn off the battery switch on the battery.

Step 4. Turn off the battery breaker switch and load breaker switch.

Step 5. Turn off the breaker on the grid side.

## 6.3. Emergency shutdown

In an emergency, press the START button on the left side of the inverter to shut down the system.

Once pressed, the system will power off immediately.

## 6.4. Restart after emergency shutdown

After the emergency is subsided, press the START button to restart the system.

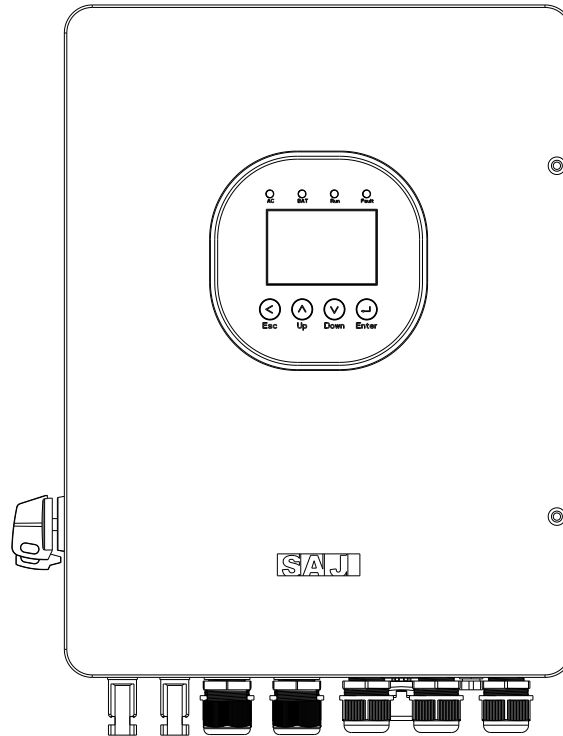

7.

**COMMISSIONING  
ON THE APP**



## 7.1. Download the App

The elekeeper App can be used for both nearby and remote monitoring. Depending on the communication module used, it supports Bluetooth/4G or Bluetooth/Wi-Fi to communicate with your energy storage system (ESS).

On your mobile phone, search for “elekeeper” in the App store and download the App.

## 7.2. Log in to the App

**Note:** The detailed operations on the App might vary, depending on the version you are using.

If you have an account, log in to the App directly:

- a. Tap the three-dot icon **•••** on the top right corner. Choose the language and network node based on your needs.
- b. Log in to the App by using the account and the password.

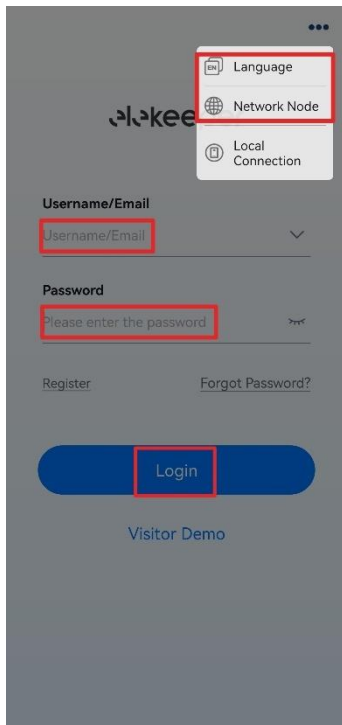

To apply for a new account, perform as follows:

- a. Tap the three-dot icon **•••** on the top right corner. Choose the language and network node based on your needs.
- b. Tap **Register**. Choose whether you are an owner or an installer or distributor.
- c. Follow the instructions on the screen to complete the registration.
- d. Log in to the App by using the new account and the password.

Example (for installer):

The first screenshot shows the login screen with a three-dot menu in the top right corner. A red box highlights the menu options: Language, Network Node, Local Connection, and a red box highlights the Register button. The Register button is also highlighted with a red box.

The second screenshot shows the 'Select Role' screen. Two options are visible: 'I'm an owner' (Real-time Monitoring and Analysis of Power Generation, Power Storage, and Power Consumption) and 'I'm an installer/distributor' (Create Plant, Monitoring & Analysis, O&M Tools). The 'I'm an installer/distributor' option is selected.

The third screenshot shows the 'Register' screen. A note at the top states: 'Note: If your company has registered an account in the system, you do not need to register. Please ask your administrator to add one in the system.' Below the note, the 'Role Type' is set to 'Installer'. The 'Username' field is empty. The 'Country/Region' field is set to 'Please select'. The 'Time Zone' field is set to 'Please select'. The 'Email' field is empty. The 'Password' field is empty. There are three checkboxes for agreements: 'Agree (User Registration Agreement)', 'Agree (Enterprise and other third-party privacy policies)', and 'Agree to receive email notifications (New Products, Events, Information) Information on new product release, events, or news'. A blue 'Confirm Registration' button is at the bottom.

## 7.3. Perform the initialization settings

### Prerequisite

The Bluetooth function on your mobile phone is enabled.

### Procedure

1. On the **Service** interface, select **Remote Configuration**. Tap **Bluetooth** and then **NEXT STEP**. Tap your inverter according to the inverter serial number (SN).

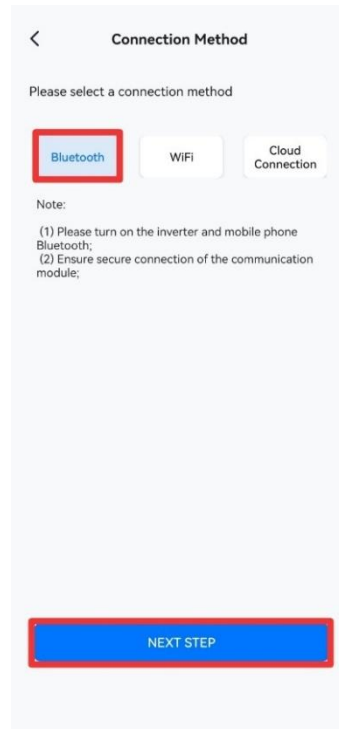
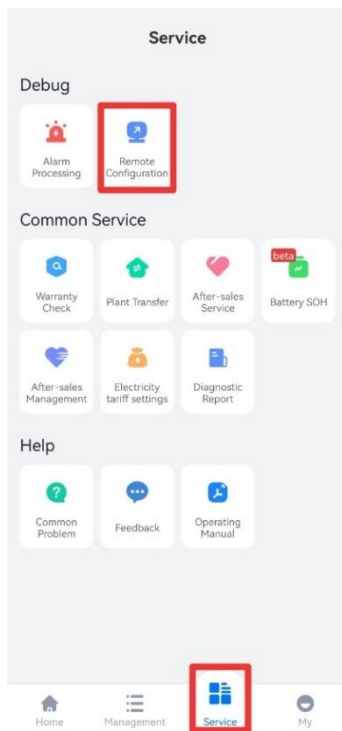



## b. Battery brand and settings

The screenshot displays three panels of the SAJ H2 series battery settings interface:

- Local Connection:** Shows connection status for Bluetooth (BlueLink) and SN-H2. The 'Battery Settings' option is highlighted with a red box.
- Battery Settings:** A list of settings including Battery Brand, Battery Parameters, Cell Voltage, Safety setting, Protection Parameters, Feature Parameters, Power Adjustment, Working Modes, Export Limitation Settings, Testing device, Parallel connection setting, and GEN Port Settings.
- Battery Brand:** A dropdown menu currently showing 'SAJ-51V'. Other options listed below are 'No Battery', 'Lead-acid', 'Normal-Li', and 'SAJ'.
- Battery Parameters:** A configuration screen with various parameters:
 

Parameter	Value	Unit
Battery Capacity	250	Ah
Charging current limit value	100.0	A
Discharge current limit value	100.0	A
Battery On-Grid Discharge Capacity Lower Limit	5	%
Battery Off-Grid Discharge Capacity Lower Limit	5	%
Battery Charge Capacity Upper Limit	100	%
Battery SOC	100	%
Battery Manual Wake-up	Wake Up Now	

## c. Meter and system schematic

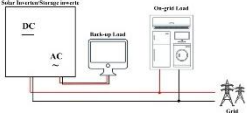
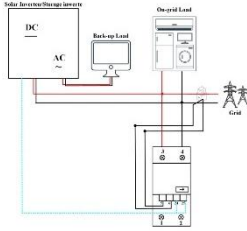
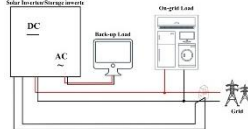
Local Connection	Testing device	Testing device	Testing device
<ul style="list-style-type: none"> <li>Bluetooth:BlueLink</li> <li>SN:H2</li> </ul>	Wiring Method No Meter	Wiring Method One Single-Phase Meter	Wiring Method CT
<ul style="list-style-type: none"> <li>Device Info</li> <li>Device Maintenance</li> <li>Safety setting</li> <li>Battery Settings</li> <li>Protection Parameters</li> <li>Feature Parameters</li> <li>Power Adjustment</li> <li>Working Modes</li> <li>Export Limitation Settings</li> <li><b>Testing device</b></li> <li>Parallel connection setting</li> <li>GEN Port Settings</li> </ul>	System Schematic 	System Schematic 	System Schematic 

## d. Export limitation settings

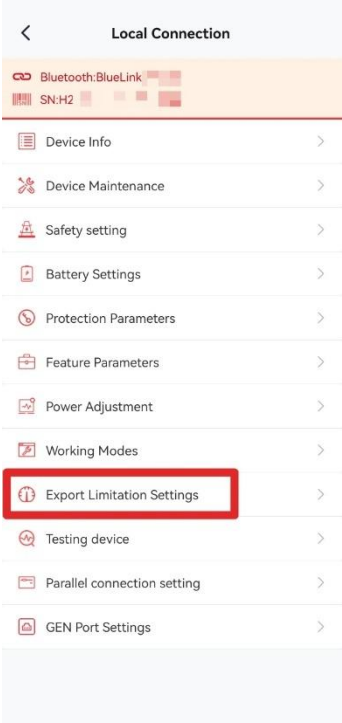

The screenshot shows the 'Local Connection' settings menu. The 'Export Limitation Settings' option is highlighted with a red box. The menu items are:

- Bluetooth:BlueLink
- SN:H2
- Device Info
- Device Maintenance
- Safety setting
- Battery Settings
- Protection Parameters
- Feature Parameters
- Power Adjustment
- Working Modes
- Export Limitation Settings**
- Testing device
- Parallel connection setting
- GEN Port Settings

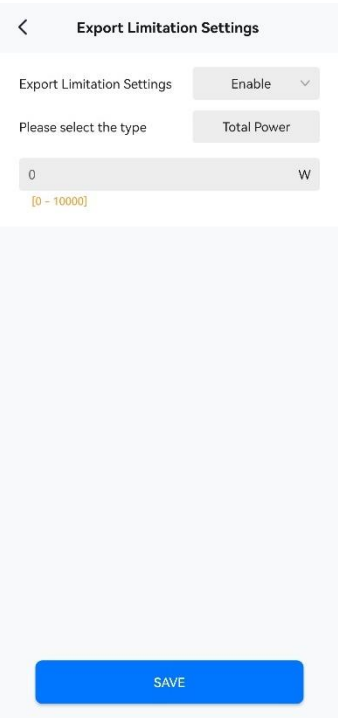

The screenshot shows the 'Export Limitation Settings' configuration screen. The settings are:

- Export Limitation Settings: Enable
- Please select the type: Total Power
- Value: 0 W
- Range: [0 - 10000]
- SAVE button

### e. Working modes

Choose the working mode: **Self-Consumption Mode**, **Time-of-use Pricing Mode**, or **Back-up Mode**.

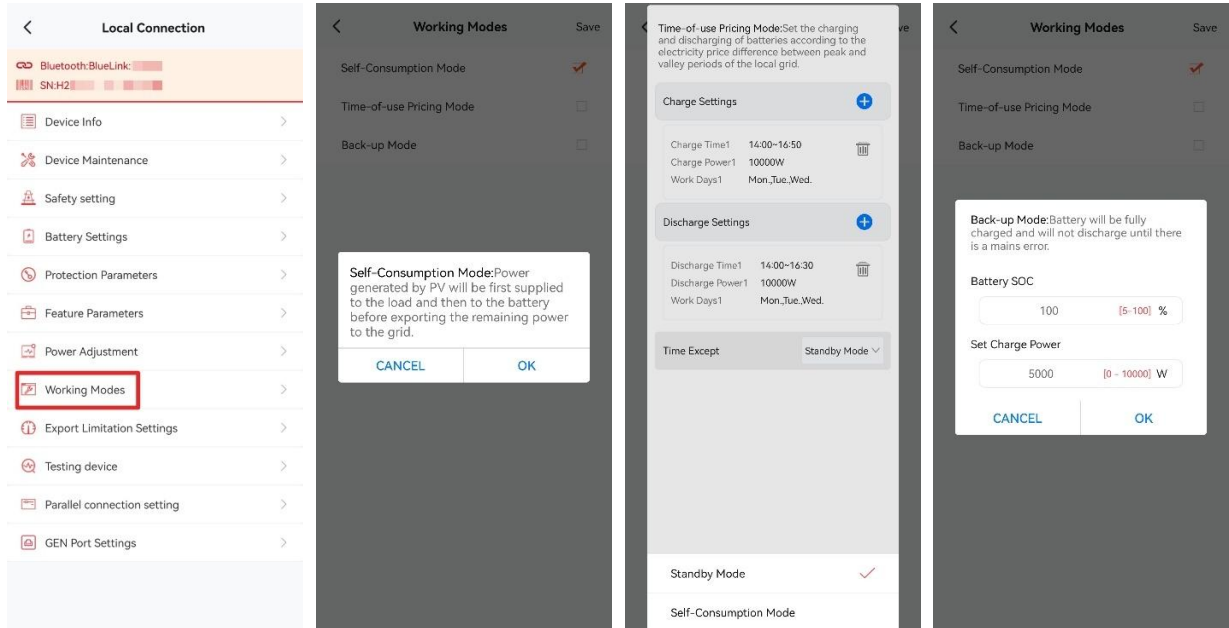

## f. Country and grid compliance

Tap **Safety Setting**. Select the **Country** and **Grid Compliance**.

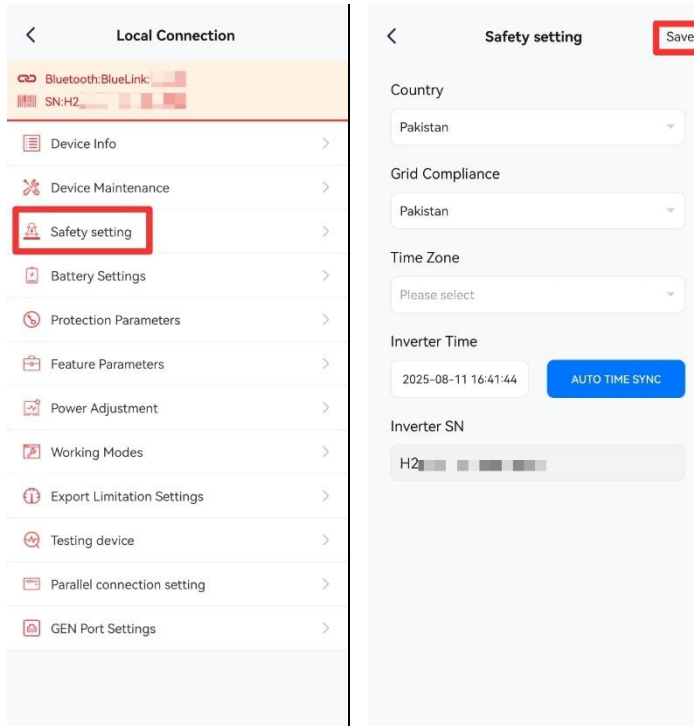

g. Initialization completion

Tap **Save** and wait 30 seconds for the parameters to be modified.

The first screenshot shows the 'Safety setting' screen with fields for Country (Pakistan), Grid Compliance (Pakistan), Time Zone (Please select), Inverter Type (2025-08), and Inverter SN (H2 5E03007). A red circle with the number '28' and the text 'Modifying... Please wait' is overlaid on the screen, indicating a 30-second timer.

The second screenshot shows the same 'Safety setting' screen with a white confirmation dialog box in the center that reads: 'Modified successfully. Please confirm whether the parameters have been modified.' with a 'GOT IT' button.

The third screenshot shows the 'Device Info' dashboard. At the top, it displays Bluetooth:BlueLink, SN:H2, and Running Status (checked). Below this is a central dashboard with icons for Diesel engine (0W), Shutdown, Total load (0W), Intelligent load (0W), and Discharging... (SOC:14.00%, 10.2KWh, 36W). At the bottom, there are several data tables:

PV Info			
PV1	0V	0A	0W
PV2	0V	0A	0W

Battery Info			
Discharging...			
Battery Type: Lithium Battery			
Battery level	10.2KWh	Remaining SOC	14.00%
V/A/W	51.8V	0.95A	50W

Load Info			
Apparent Power		70VA	
1	Active Power	0W	
V/A/F		220.9V/0.31A/49.99Hz	

Grid Info				
L1	218.4V	0.30A	49.97Hz	0W

GEN information				
Total Power				0W
V/A/W/F	1.2V	0.07A	0W	49.99Hz

Update on: 2025-08-11 16:44:04

## 7.4. Configure the communication module

### About this task

To remotely monitor the energy storage system and view the device statistics (for example, when you are away from home), connect the communication module installed on the inverter to the network.

### Procedure

1. On the **Device List** page, select your communication module according to its SN.
2. Tap the setting icon  on the upper right corner.
3. Select **WiFi Configuration** and set the communication module to connect to your home network.

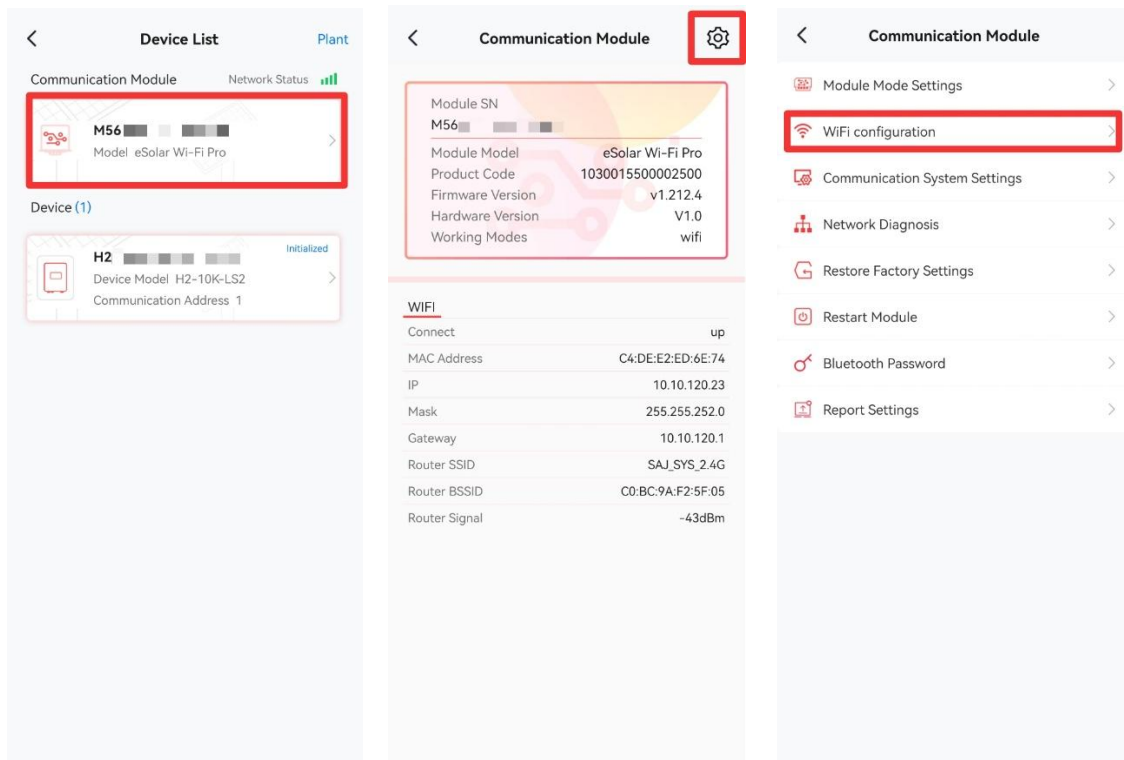

## 7.5. Create a plant

1. On the **Management** page, tap the ⊕ icon on the top right corner. Select **Create Plant for Owner**.

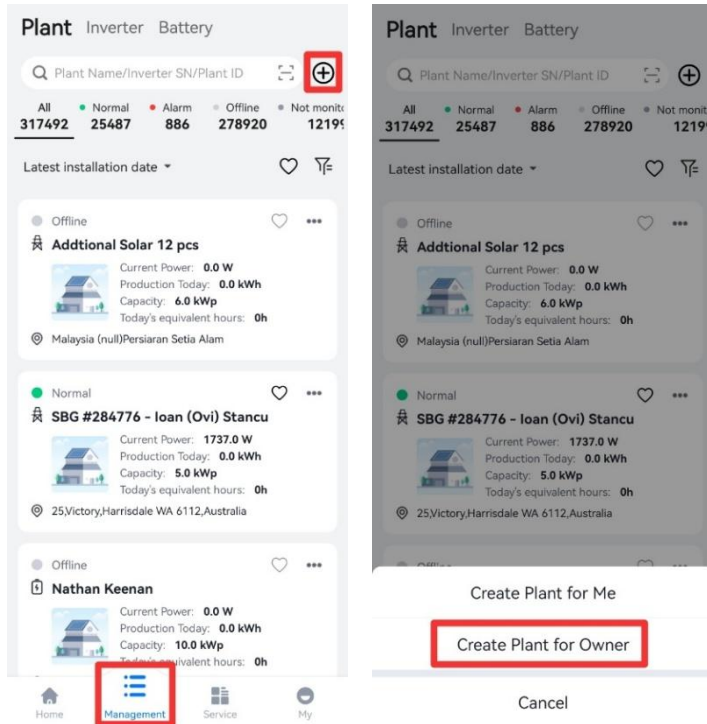

## 2. Apply for an account for the end user.

The image displays three sequential screenshots of a mobile application interface for creating an account for an end user.

**Left Screenshot: My Customers**

- Header: My Customers
- Customer 1: v\*\*a, 11/08/2025, v\*\*\*@yahoo.com.au. Buttons: Delete, Create Plant for Owner.
- Customer 2: t\*\*\*@yahoo.com.br, 11/08/2025, t\*\*\*@yahoo.com.br. Buttons: Delete, Create Plant for Owner.
- Customer 3: k\*\*\*\*\*g, 11/08/2025, k\*\*\*@khanganfoods.com. Buttons: Delete, Create Plant for Owner.
- Customer 4: J\*\*\*\*\*O, 11/08/2025, j\*\*\*@gmail.com. Buttons: Delete, Create Plant for Owner.
- Customer 5: Q\*\*\*\*\*n, 11/08/2025, q\*\*\*@khanganfoods.com. Buttons: Delete, Create Plant for Owner.
- Bottom button: Register the owner's account.

**Middle Screenshot: Create Account**

- Header: Create Account
- Username: Please enter
- Country/Region: Please select
- Time Zone: Please select
- Email: Please enter a valid Email
- Password: Please enter
- Authorization options:
  - I have obtained the user's authorization
  - Yes, please keep me updated on news, events and offers.
- Disclaimer: If the content you entered involves Third-party personal information, please obtain authorization in advance.
- Bottom button: Register

**Right Screenshot: My Customers**

- Header: My Customers
- Customer 1: v\*\*a, 11/08/2025, v\*\*\*@yahoo.com.au. Buttons: Delete, Create Plant for Owner.
- Customer 2: t\*\*\*@yahoo.com.br, 11/08/2025, t\*\*\*@yahoo.com.br. Buttons: Delete, Create Plant for Owner.
- Customer 3: k\*\*\*\*\*g, 11/08/2025, k\*\*\*@khanganfoods.com. Buttons: Delete, Create Plant for Owner.
- Customer 4: J\*\*\*\*\*O, 11/08/2025, j\*\*\*@gmail.com. Buttons: Delete, Create Plant for Owner.
- Customer 5: Q\*\*\*\*\*n, 11/08/2025, q\*\*\*@khanganfoods.com. Buttons: Delete, Create Plant for Owner.
- Bottom button: Register the owner's account.

### 3. Configure the plant details.

The image displays three sequential screenshots of a mobile application's 'Add' screen for configuring plant details. The first screenshot shows the 'Create Plant' button highlighted with a red box. The second screenshot shows the 'Next' button highlighted with a red box. The third screenshot shows the 'Create Plant' button highlighted with a red box.

The 'Add' screen contains the following fields and options:

- Plant Owner
- Name: Test Demo Plant
- Capacity: 10 kWp
- Country/Region: China
- Location
- Detailed Address
- Use Type: Home Use
- Number of Components: Please enter
- PV Panel Azimuth

The 'Device 1' section includes:

- SN
- HS
- Device Capacity: 10 kWp

## 7.6. View the fixed power factor mode and fixed reactive power mode

Once **Country and Grid Compliance** are selected during initialization, the parameters relating to the reactive power control settings are set automatically. In typical household scenarios, these default values generally require no adjustment.

If adjustment is necessary, before any modifications, contact SAJ for consultation and ensure that you have the necessary electrical knowledge and are fully aware of the impact of such modifications.

To view the settings, perform as follows:

Depending on your inverter manufacturing date, view the parameter values as follows:

- For **Reactive Power Compensation Mode**:
  - Fixed power factor mode:  
**Capacitive Power Factor Adjustment** or **Inductive Power Factor Adjustment**.  
The power factor range is from 0.8 leading to 0.8 lagging.
  - Fixed reactive power mode:  
**Inductive Adjustment (Var)** or **Capacitive Adjustment (Var)**.  
The power ranges from  $-60\% P_n$  to  $60\% P_n$ .

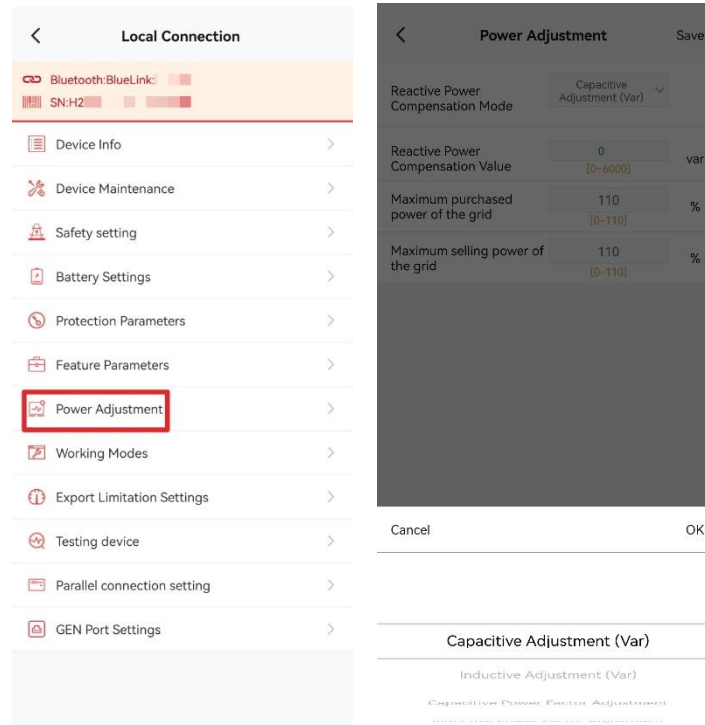

# 8.

## COMMISSIONING ON THE LCD

For fast commissioning or when the network connection is unavailable or unstable, configure the ESS on the touchscreen.



Liquid Crystal Display (LCD) on the front panel of the inverter. Alternatively, on the LCD, you can also view the settings that you configured on the elekeeper App and current working data of the ESS.

## 8.1. Operations on the main screen

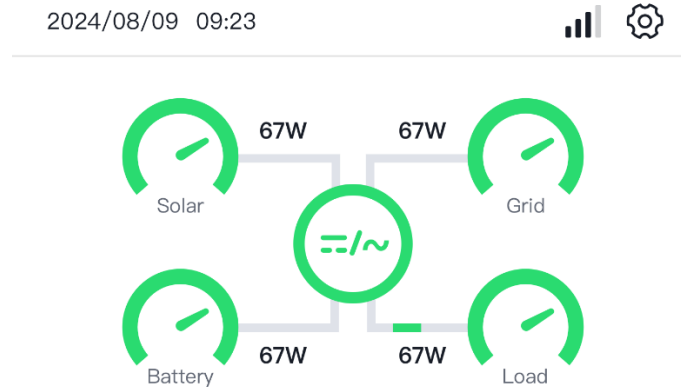

The main screen provides access to information about the inverter, solar, grid, battery, and loads. In addition, it illustrates the energy flow direction.

-  in the center of the screen: Inverter information  
It can be displayed in one of the following statuses:

Color	Status	Description
Green	Running	The system is working properly.
Red	Error	An error has occurred.
Yellow	Alarm	An alarm is reported.
Blue	Upgrading	The system is upgrading.

Tap this icon to view the following:

- Working mode
- Current warning
- History warnings

-  **Solar:** PV array information

Tap this icon to view the following:

- Generated power
- Today's energy
- Total energy
- Voltage, current, and power of current PV arrays

●  **Grid:** Grid information

Tap this icon to view the following:

- Status
- Power
- Frequency
- Voltage
- Current
- Power imported from the grid (today's data and total data)
- Power exported to the grid (today's data and total data)

●  **Battery:** Battery information

Tap this icon to view the following:

- Brand
- Status
- Capacity
- SOC
- Voltage
- Current
- Temperature

●  **Load:** Load information

Tap this icon to view the following:

- Runtime of current home loads on the battery power in off-grid status
- Load voltage
- Load current
- SmartLoad power (It is displayed only when **SmartLoad Settings** is selected in **Port Access Enable**.)

## 8.2. Settings

To configure system parameters via the LCD interface, perform as follows.

Step 1. Tap the setting icon  on the top right corner of the main screen.

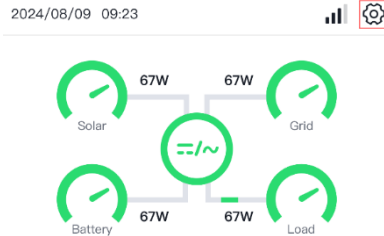

Step 2. Enter the default password 8888 and tap ENT to access the settings menu.

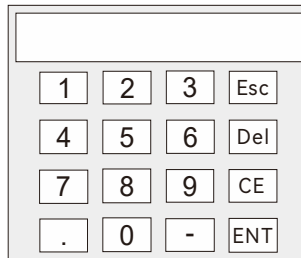

The key functions of the on-screen keypad are as follows.

- 0-9: Input digits.
- Esc: Cancel and exit.
- Del: Delete last character.
- CE: Clear all input.
- ENT: Submit password.

Step 3. Access the settings menu successfully and start configuring system parameters as required.

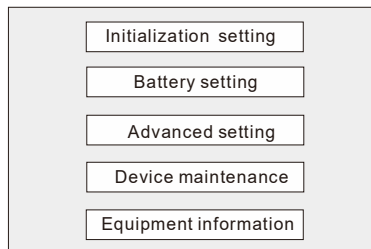

### 8.2.1. Initialization setting

All the initialization parameters can be set through this interface.

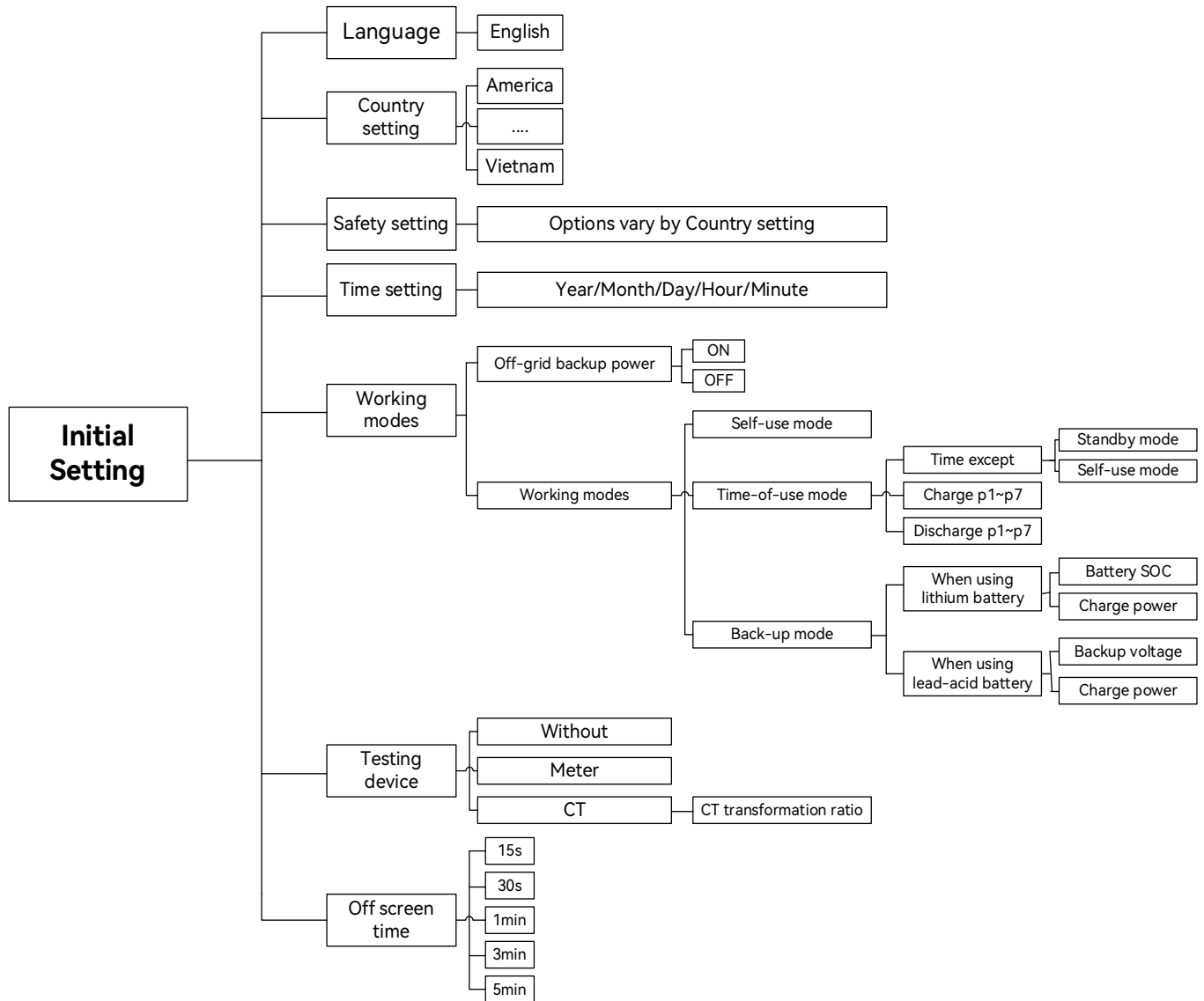

In Working modes:

- **Off-grid backup power:**  
If enabled, in off-grid status, the backup loads will use the power from the PV or battery.
- **Self-use mode:**  
The generated PV energy is provided to the devices in order: loads > batteries > grid
- **Time-of-use mode:**
  - Charge p1~p7: Battery charges during these periods.
  - Discharge p1~p7: Battery discharges during these periods.
  - Time except:  
During the preset charging or discharging periods, batteries can only operate in charging or discharging status. During time except charge p1~p7 and discharge p1~p7, the battery can work in standby mode or self-use mode.
- **Battery SOC:**  
Configure a set value for battery SOC.  
When the battery SOC is lower than the configured SOC value, the batteries can only be in charging status without discharging.  
When the battery SOC reaches the configured SOC value, the batteries will stop charging.  
When the battery SOC is higher than the configured SOC value, the batteries will work in self-use mode.

**In Testing device:**

- **Without:** No meter or CT is connected.
- **Meter:** Meter(s) has been connected.
- **CT:** CT(s) has been connected.

## 8.2.2. Battery setting

Set the battery-related parameters based on your needs.

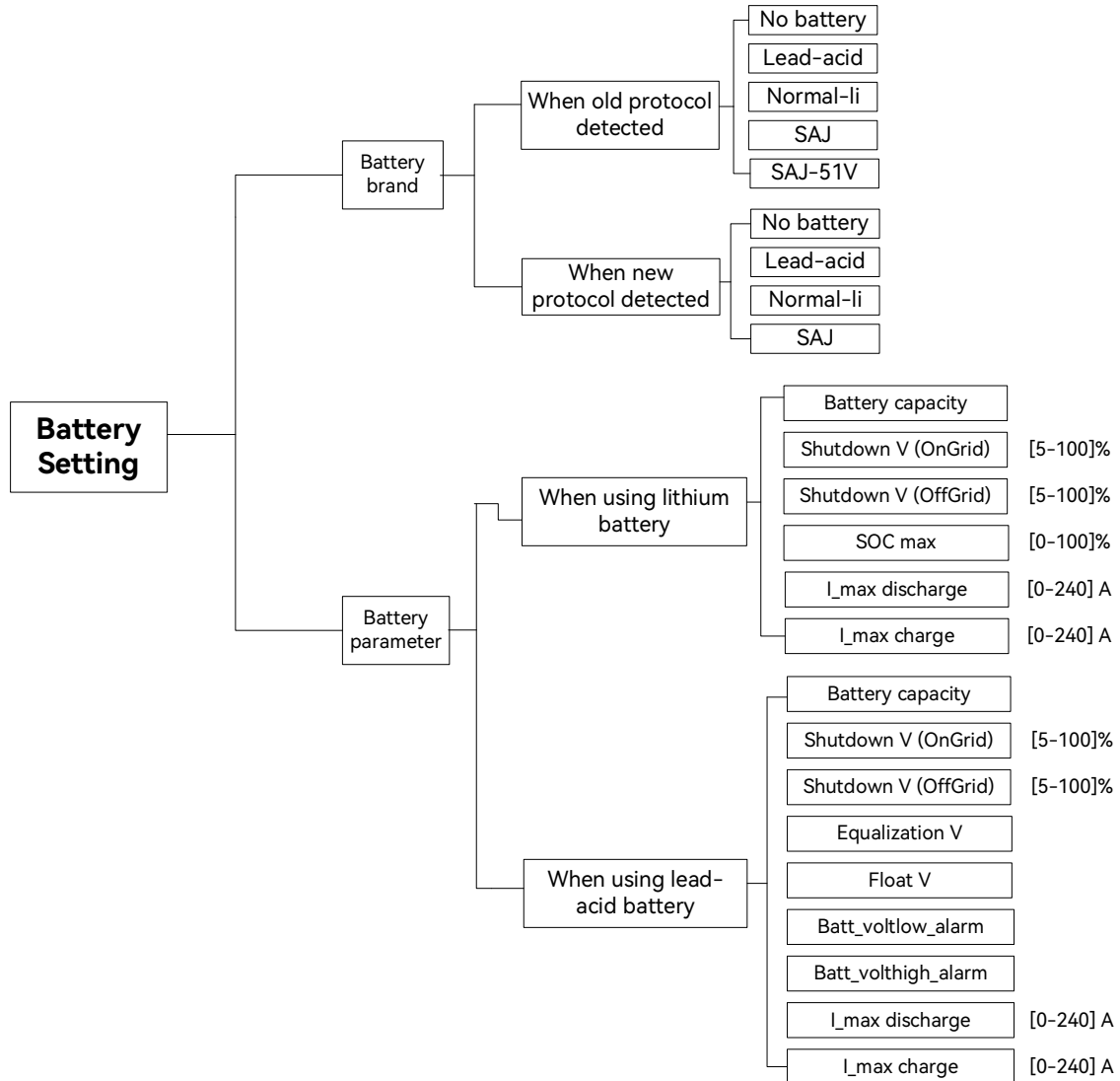

### 8.2.3. Advanced setting

Set the inverter-related advanced setting based on your needs.

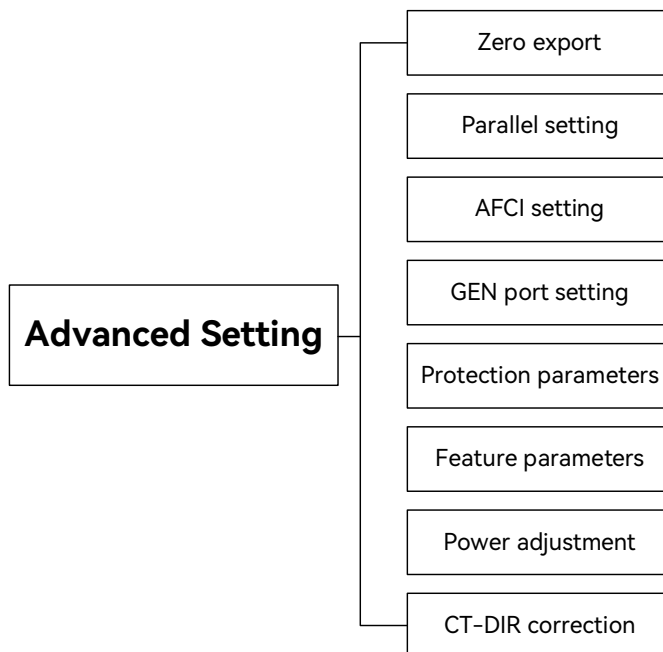

#### 8.2.3.1. Zero export

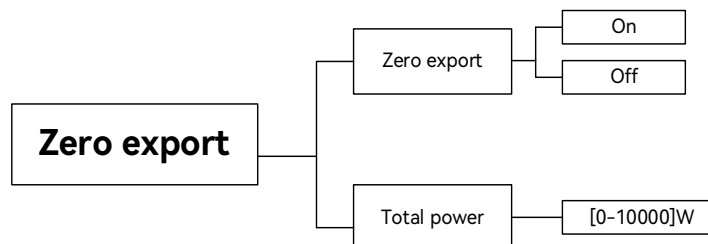

When **Zero Export** is enabled, set **Total Power** to limit the maximum power exported to the grid.

### 8.2.3.2. Parallel setting

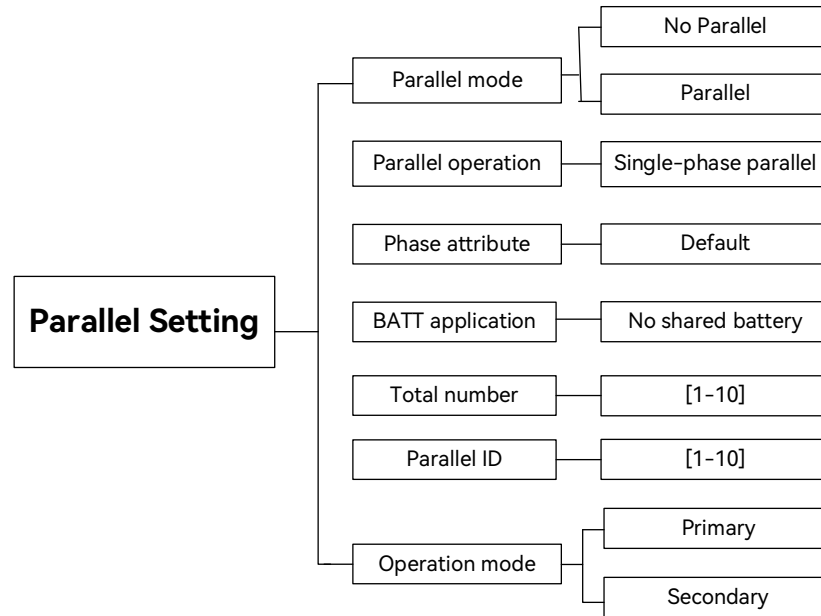

By default, the inverter configured with **Parallel ID 1** will work as the primary device (in the **Primary** operation mode). If you assign **Primary** mode to another inverter (e.g., **Parallel ID 2**), the device configured with **Parallel ID 1** will switch to **Secondary mode**.

### 8.2.3.3. AFCI setting (optional)

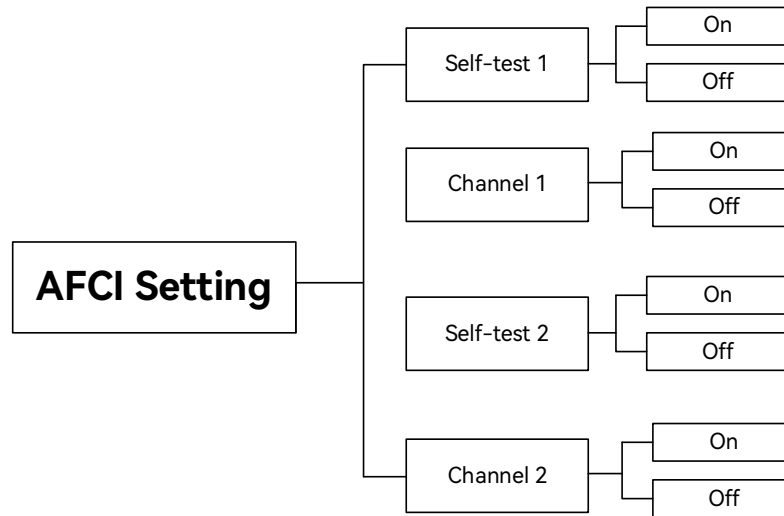

With the Arc-fault circuit-interrupter (AFCI) protection, when there is an arc signal on the DC side due to aging of the cable or loose contact, the inverters can quickly detect it and cut off the power to prevent fire and ensure the PV system safety.

The AFCI function is enabled for all channels by default. For channel 1 and 2, the AFCI protection works only when **Self-test** and **Channel** are both enabled.

### 8.2.3.4. GEN port settings

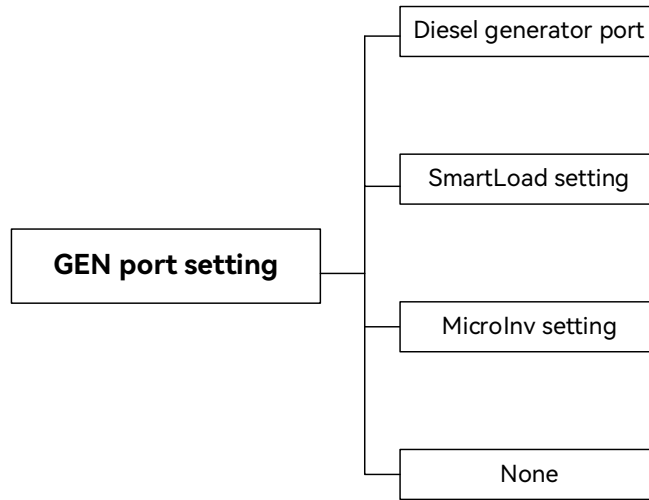

In **GEN port setting**:

- **Diesel generator port:**  
If selected, the connected generator will output its generated power to household loads through this port based on the conditions set in this area.
- **SmartLoad setting:**  
If selected, the connected household load will start and stop working based on the **Turn-on SOC** and **Turn-off SOC** values.
- **MicroInv setting:**  
If selected, the connected microinverter will start and stop working based on the **Turn-on SOC** and **Turn-off SOC** values.
- **None:**  
No setting is required.

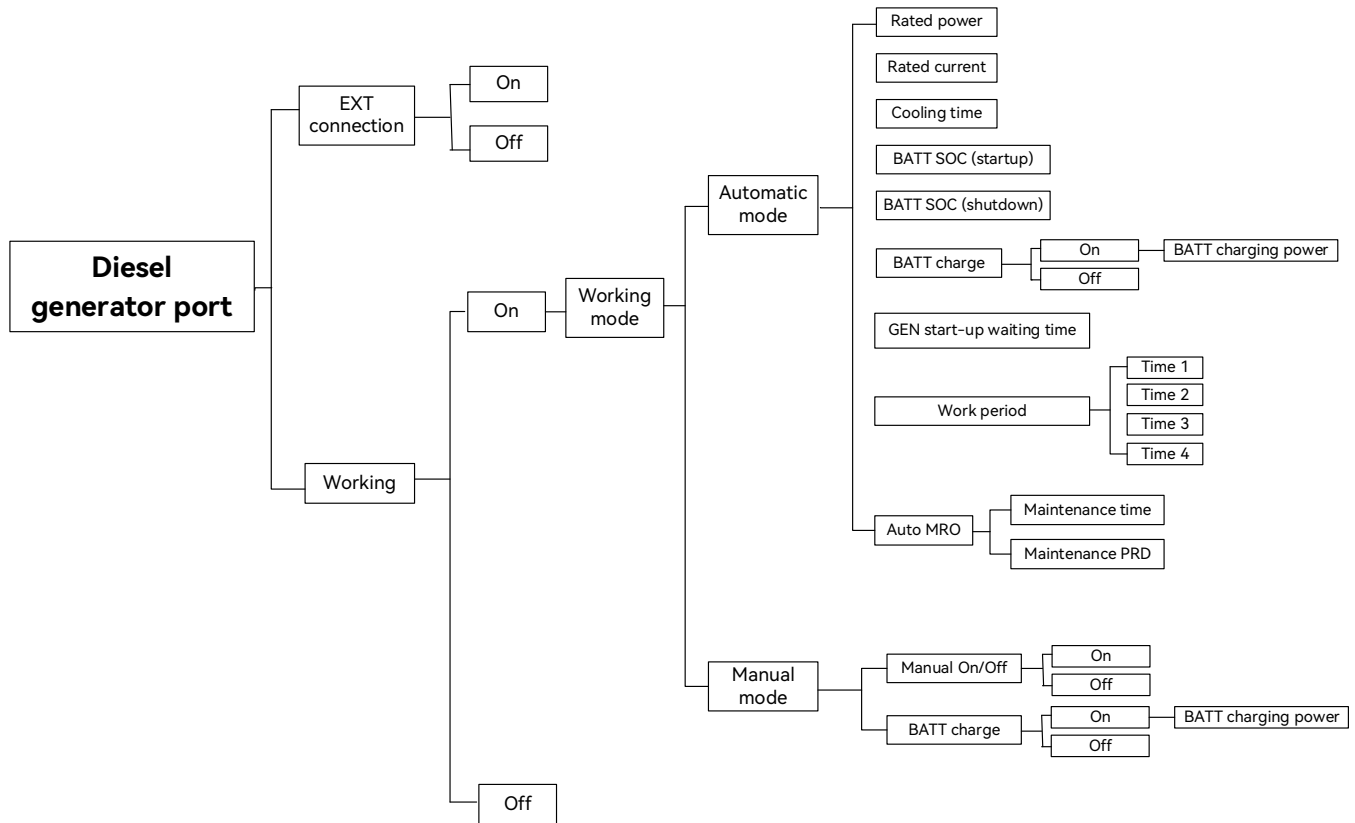

In **Working mode**:

- **Automatic mode**: If you select this mode, the generator will work based on the settings. For example, BATT charge in ON status indicates that the power generated by the generator will be used for battery charging.
- **Auto MRO**: Automatic maintenance and protection function.
- **Maintenance PRD**: Maintenance once per  $N$  days.

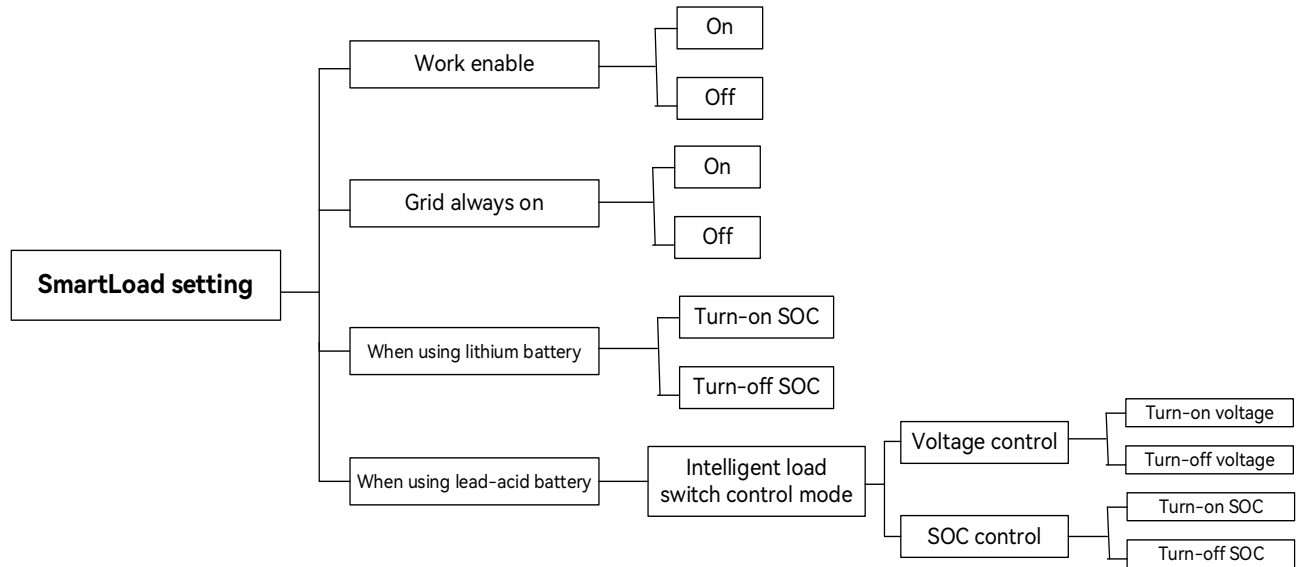

- **Grid always on:**

If enabled, the connected device keeps working as long as the grid power is detected. If disabled, this device might not work even if the grid power is detected.

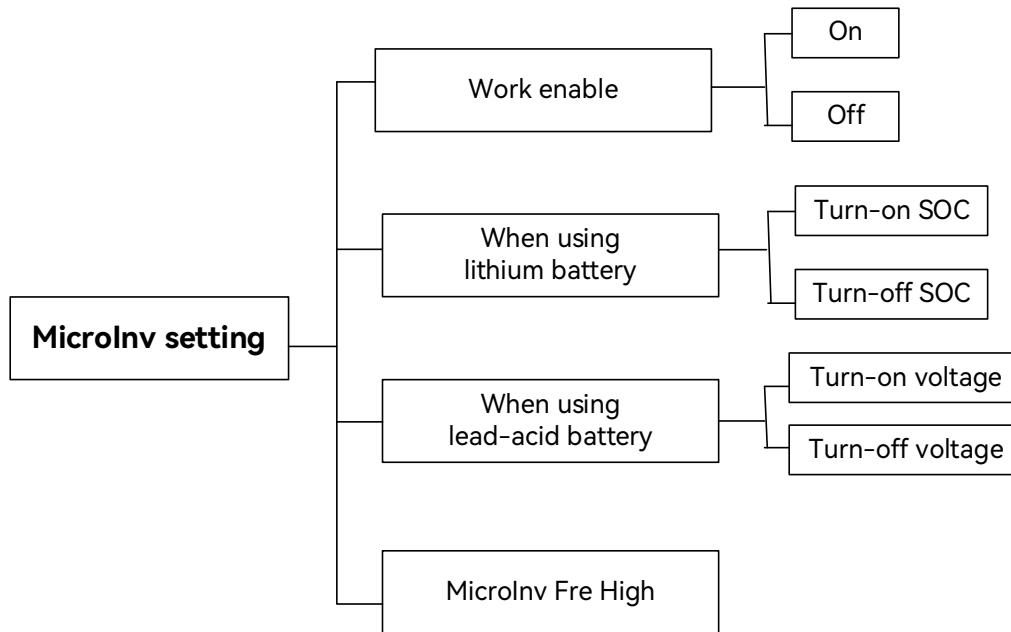

- If you select **Lead-acid** in **Battery Brand**, **Turn-on voltage** and **Turn-off voltage** will be displayed.
- If you select **Lithium Battery** in **Battery Brand**, **Turn-on SOC** and **Turn-off SOC** will be displayed.
- In **MicroInv Fre High**, you can set the upper threshold of the microinverter frequency.

### 8.2.3.5. Protection parameters

Configure the multi-level protection settings here, including thresholds and disconnection times for overvoltage, undervoltage, over-frequency, and under-frequency conditions.

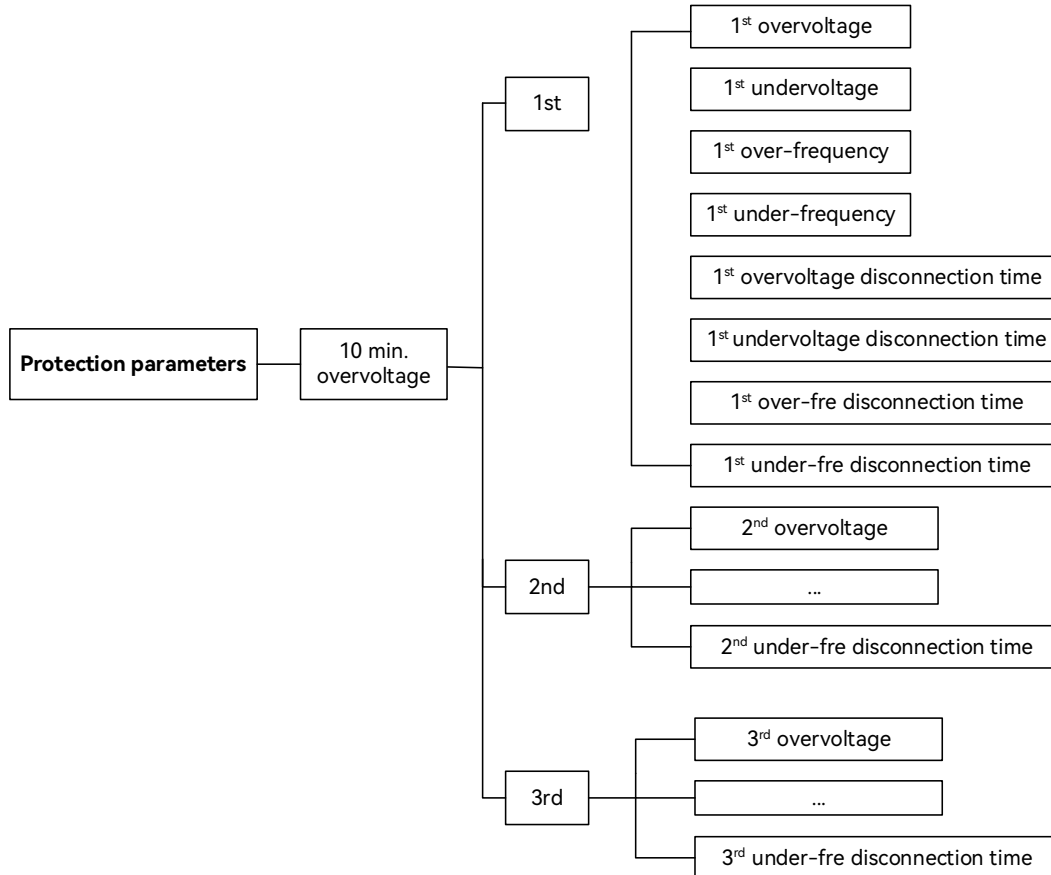

### 8.2.3.6. Feature parameters

Configure feature parameters of the inverter, including safety checks, grid compliance functions, power control options, and operational modes.

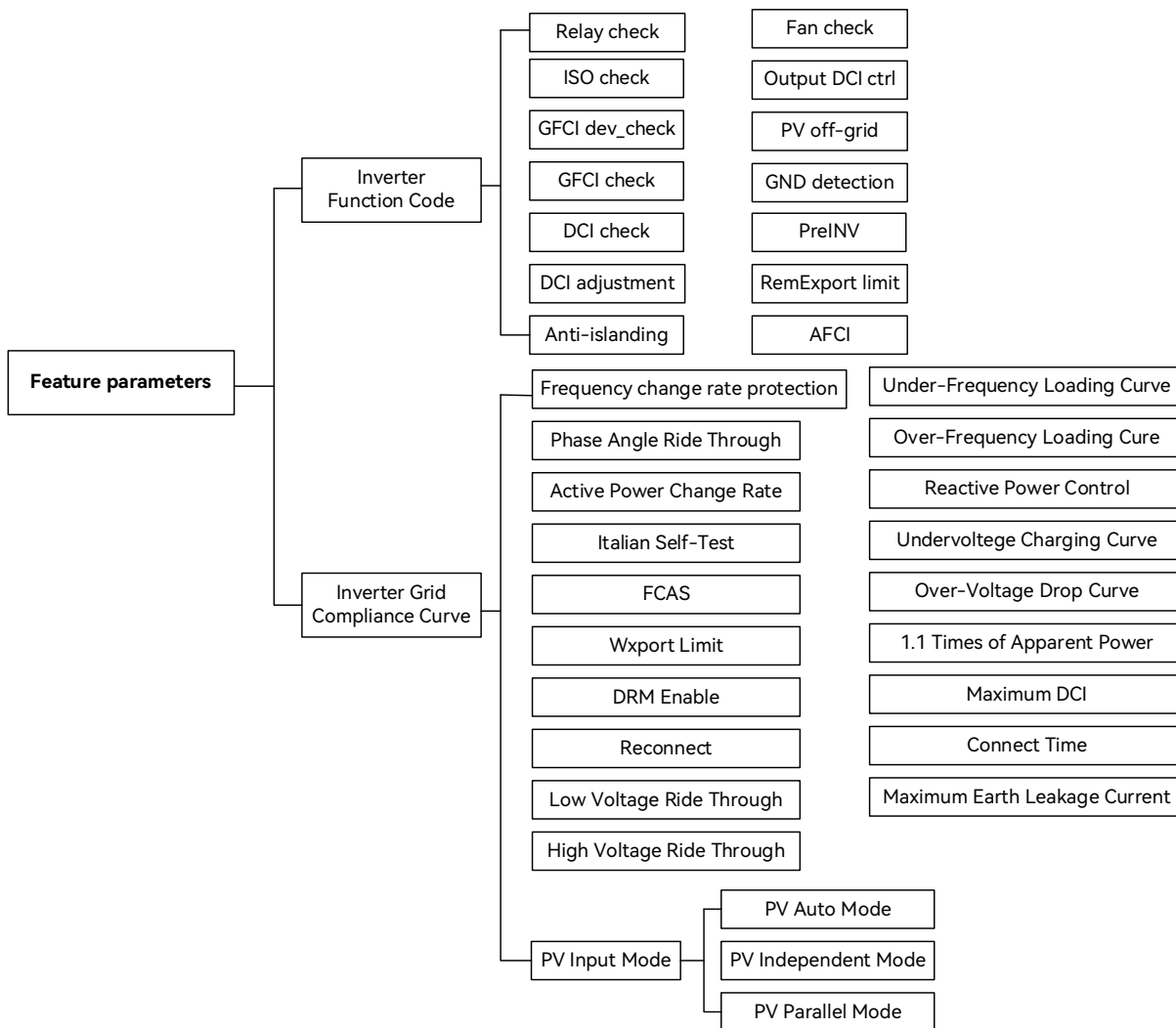

### 8.2.3.7. Power adjustment

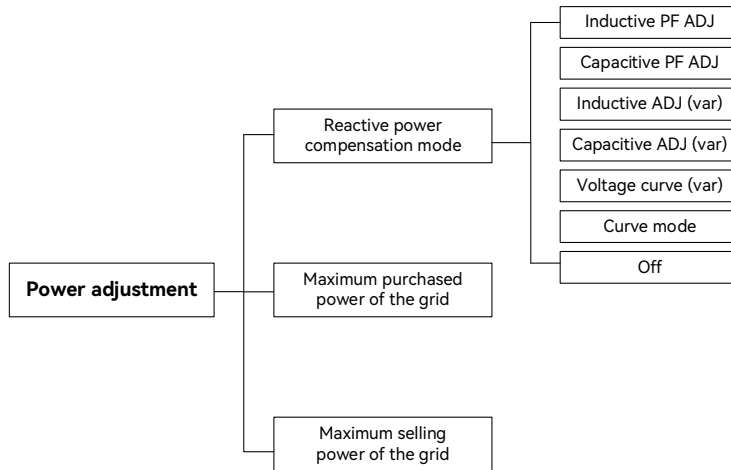

- **Inductive PF ADJ:** Automatically generates capacitive reactive power to correct an inductive power factor.
- **Capacitive PF ADJ:** Automatically generates inductive reactive power to correct a capacitive power factor.
- **Inductive ADJ (var):** Set a fixed value of inductive reactive power for the system to absorb.
- **Capacitive ADJ (var):** Set a fixed value of capacitive reactive power for the system to generate.

### 8.2.3.8. CT-DIR correction

Configure the current transformer direction for both grid-side and PV-side connections to ensure accurate power flow measurement and system protection.

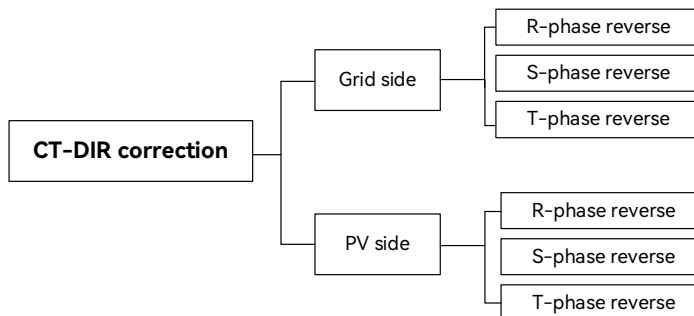

## 8.2.4. Device setting

Perform various device maintenance operations here, including system resets, data clearance, error log management, and operational controls.

**Note:** All the configurations will be lost after the **Reset** action.

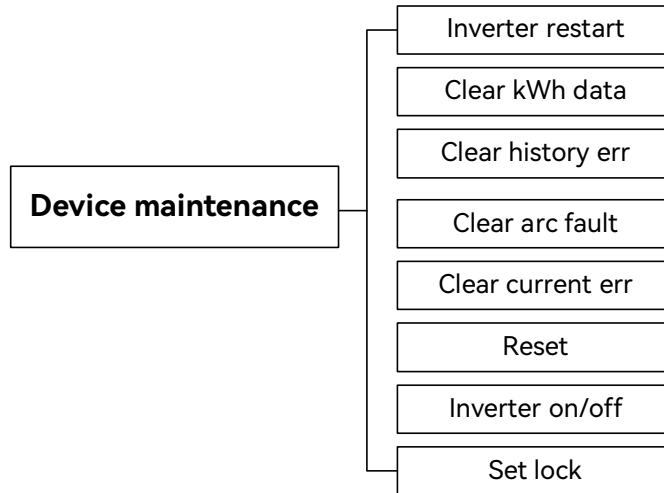

## 8.2.5. Equipment information

View the details about the inverter.

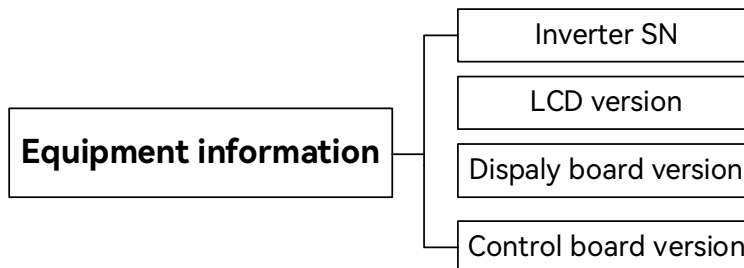

9.

**TROUBLESHOOTING**



**NOTICE**

The operations and maintenance must be performed by authorized technicians.

For the errors reported below, take the suggested troubleshooting actions in the listed order first. If the error is still present after taking the suggested solutions or no specific action is suggested, contact the installer or SAJ technical support.

Error Code	Message	Possible cause	Solutions
1	Master Relay Error	1. Live wire grounding on grid side 2. Grid voltage too low 3. Inverter relay circuit fault	1. Measure the voltage between the ground wire and the neutral wire to see if it exceeds 10V. 2. Measure if the grid voltage is too low.
2	Master EEPROM Error	Inverter internal memory fault	1. Disconnect AC and DC switches for 5 minutes, then restart the inverter. 2. Check if there is a firmware upgrade and whether the correct firmware version is selected.
3	Master Temperature High Error	Inverter temperature too high	1. Check if the inverter's heat dissipation path is blocked. 2. Check if the inverter is installed in direct sunlight. 3. Check if the installation environment has good ventilation.
4	Master Temperature Low Error	Inverter temperature too low	Check if the ambient temperature at the inverter installation location is too low
5	Master Lost Communication M<->S	Internal communication loss in inverter	Disconnect AC and DC switches for 5 minutes, then restart the inverter.
6	Master GFCI Device Error	Inverter leakage current detection device failure	
7	Master DCI Device Error	Inverter DC component detection device failure	
8	Master Current Sensor Error	Inverter current detection device failure	1. Disconnect AC and DC switches for 5 minutes, then restart the inverter. 2. Check if the string MC4 connectors have reversed polarity.
9	Master Phase1 Voltage High	Grid voltage exceeds the safety permissible range of the inverter	1. Check if the grid voltage is too high. 2. Check if the inverter AC output cable connections are secure and if the grid-tie cable is too thin. 3. Check if the inverter grid compliance specifications are selected correctly.
10	Master Phase1 Voltage Low	Grid voltage below the safety permissible range of the inverter	1. Check if the grid voltage is too low. 2. Check if the inverter AC output cable connections are secure. 3. Check if the inverter grid compliance specifications are selected correctly.
11	Master Phase2 Voltage High	Grid voltage exceeds the safety permissible range of the inverter	1. Check if the grid voltage is too high. 2. Check if the inverter AC output cable connections are secure and if the grid-tie cable is too thin. 3. Check if the inverter grid compliance specifications are selected correctly.

12	Master Phase2 Voltage Low	Grid voltage below the safety permissible range of the inverter	<ol style="list-style-type: none"> <li>1. Check if the grid voltage is too low.</li> <li>2. Check if the inverter AC output cable connections are secure.</li> <li>3. Check if the inverter grid compliance specifications are selected correctly.</li> </ol>
13	Master Phase3 Voltage High	Grid voltage exceeds the safety permissible range of the inverter	<ol style="list-style-type: none"> <li>1. Check if the grid voltage is too high.</li> <li>2. Check if the inverter AC output cable connections are secure and if the grid-tie cable is too thin.</li> <li>3. Check if the inverter grid compliance specifications are selected correctly.</li> </ol>
14	Master Phase3 Voltage Low	Grid voltage below the safety permissible range of the inverter	<ol style="list-style-type: none"> <li>1. Check if the grid voltage is too low.</li> <li>2. Check if the inverter AC output cable connections are secure.</li> <li>3. Check if the inverter grid compliance specifications are selected correctly.</li> </ol>
15	Master Voltage 10Min High	Grid voltage exceeds the safety permissible range of the inverter	<ol style="list-style-type: none"> <li>1. Check if the grid voltage is too high.</li> <li>2. Check if the inverter AC output cable connections are secure and if the grid-tie cable is too thin.</li> <li>3. Check if the inverter grid compliance specifications are selected correctly.</li> </ol>
16	Master OffGrid Voltage Low	Excessive load power on off-grid port, low battery SOC, or high/low battery temperature causing derated battery output	<ol style="list-style-type: none"> <li>1. Reduce the load connected to the off-grid port.</li> <li>2. Check if the battery charge is too low.</li> <li>3. Check if the battery ambient temperature is too high or too low.</li> </ol>
17	Master Output_Shorter	External wiring short circuit at back-up port	Correct the external wiring of the back-up port.
18	Master Grid Frequency High	Grid frequency exceeds local grid upper limit	<ol style="list-style-type: none"> <li>1. Check if the inverter grid compliance specifications are selected correctly.</li> <li>2. Disconnect AC and DC switches for 5 minutes, then restart the inverter.</li> </ol>
19	Master Grid Frequency Low	Grid frequency below local grid lower limit	
20	BATInputMode Error	Batteries not connected in parallel as required	<ol style="list-style-type: none"> <li>1. Check if the configured battery input mode is correct</li> <li>2. If the battery input is confirmed to be in parallel mode, check if all battery connections are secure.</li> </ol>
21	Master Phase1 DCV Error	DC component of AC output exceeds limit	Disconnect AC and DC switches for 5 minutes, then restart the inverter.
22	Master Phase2 DCV Error	DC component of AC output exceeds limit	
23	Master Phase3 DCV Error	DC component of AC output exceeds limit	
24	Master No Grid Error	Inverter cannot detect grid voltage	<ol style="list-style-type: none"> <li>1. Confirm whether the grid is powered off, check if the grid-tie box switch has tripped, and ensure the inverter AC cables are securely connected.</li> <li>2. If there is no power outage, disconnection, or loose connections after the above checks, close the AC switch and reconnect to the grid.</li> </ol>
25	DC ReverseConnect Error	Reverse polarity connection at PV or battery ports	Check the DC port wiring.

26	Parallel machine CAN Com Error	Parallel system CAN communication failure	Check the parallel system CAN communication wiring.
27	Master GFCI Error	System ground leakage current fault detected	<ol style="list-style-type: none"> <li>1. Disconnect AC and DC switches, check if the AC output ground wire is secure and if the AC wiring is correct.</li> <li>2. Check if the AC/DC cables are damaged or soaked, and if the panels are soaked.</li> </ol>
28	Master Phase1 DCI Error	DC component of AC output exceeds limit	Disconnect AC and DC switches for 5 minutes, then restart the inverter.
29	Master Phase2 DCI Error	DC component of AC output exceeds limit	
30	Master Phase3 DCI Error	DC component of AC output exceeds limit	
31	Master ISO Error	PV string insulation resistance to ground below set value	<ol style="list-style-type: none"> <li>1. Disconnect AC and DC switches, check if the AC output ground wire is secure and if the AC wiring is correct.</li> <li>2. Check if the AC/DC cables are damaged or soaked, and if the panels are soaked.</li> </ol>
32	Master Bus Voltage Balance Error	Bus voltage imbalance	Disconnect AC and DC switches for 5 minutes, then restart the inverter.
33	Master Bus Voltage High	DC input voltage exceeds the allowable input limit of the inverter	<ol style="list-style-type: none"> <li>1. Check the number of panels in each string, calculate whether the open-circuit voltage of the string exceeds the maximum input voltage of the inverter.</li> <li>2. If the above checks confirm no issues, close the AC switch and restart the inverter.</li> </ol>
34	Master Bus Voltage Low	Bus voltage of the inverter is too low	Disconnect AC and DC switches for 5 minutes, then restart the inverter.
35	Master Grid Phase Error	Abnormal phase sequence between three-phase power	Measure the voltage between each phase of the three-phase power to check if it is normal.
36	Master PV Voltage High Error	DC input voltage of the inverter is too high	<ol style="list-style-type: none"> <li>1. Check the number of panels in each string, calculate whether the open-circuit voltage of the string exceeds the maximum input voltage of the inverter.</li> <li>2. If the above checks confirm no issues, close the AC switch and restart the inverter.</li> </ol>
37	Master Islanding Error	Grid loss causing islanding effect	<ol style="list-style-type: none"> <li>1. Confirm whether the grid is powered off, check if the grid-tie box switch has tripped, and ensure the inverter AC cables are securely connected.</li> <li>2. If there is no power outage, disconnection, or loose connections after the above checks, close the AC switch and reconnect to the grid.</li> </ol>
38	Master HW Bus Voltage High	DC input voltage exceeds the allowable input limit of the inverter	<ol style="list-style-type: none"> <li>1. Check the number of panels in each string, calculate whether the open-circuit voltage of the string exceeds the maximum input voltage of the inverter.</li> <li>2. If the above checks confirm no issues, close the AC switch and restart the inverter.</li> </ol>

39	Master HW PV Current High	1. PV string positive and negative poles are reversed 2. Inverter internal damage	1. Check whether the positive and negative poles of the string are reversed. 2. If the above checks confirm no issues, close the AC switch and restart the inverter.
41	Master HW Inv Current High	Grid-side output current exceeds the inverter limit	1. Disconnect AC and DC switches, check if the AC cables are securely connected. 2. If the above checks confirm no issues, close the AC switch and restart the inverter.
44	Master Grid NE Voltage Error	Live wire grounding on grid side	1. Measure the voltage between the ground wire and the neutral wire. 2. If it exceeds 10V, it indicates a live wire grounding issue.
45	Master Fan1 Error	Fan blade stuck or damaged	1. Check if the external fan (if present) is operating normally. 2. If the fan is operating normally but the fault persists, disconnect AC and DC switches for 5 minutes and restart the inverter.
46	Master Fan2 Error	Fan blade stuck or damaged	
47	Master Fan3 Error	Fan blade stuck or damaged	
48	Master Fan4 Error	Fan blade stuck or damaged	
49	Lost Communication between DSP and PowerMeter	Communication abnormality between inverter and meter	1. Confirm whether the meter is working properly. 2. Check if the communication wiring between the inverter and the meter is secure. 3. Verify that the communication parameter settings between the inverter and the meter are correct, including address, baud rate, etc.
50	Lost Communication between M<->S	Internal communication loss in inverter	Disconnect AC and DC switches for 5 minutes, then restart the inverter.
51	Lost Communication between inverter and Grid Meter	Communication abnormality between inverter and grid meter	1. Confirm whether the meter is working properly. 2. Check if the communication wiring between the inverter and the meter is secure. 3. Verify that the communication parameter settings between the inverter and the meter are correct, including address, baud rate, etc.
52	HMI EEPROM Error	Inverter internal memory fault	1. Disconnect AC and DC switches for 5 minutes, then restart the inverter. 2. Check if there is a firmware upgrade and whether the correct firmware version is selected.
53	HMI RTC Error	RTC fault	Contact the installer.
54	BMS Device Error	Battery abnormality	
55	BMS Lost.Conn Warn	BMS not started properly	1. Check if the BMS button is turned on. 2. Check if the BMS button is lit.
59	Lost Communication between inverter and PV Meter	Communication loss between inverter and PV meter	1. Confirm whether the meter is working properly. 2. Check if the communication wiring between the inverter and the meter is secure. 3. Verify that the communication parameter settings between the inverter and the meter are correct, including address, baud rate, etc.
60	EV_Lost.Conn Warn	Communication loss between charging pile and inverter	Contact the installer.

61	Slave Phase1 Voltage High	Grid voltage exceeds the safety permissible range of the inverter	<ol style="list-style-type: none"> <li>1. Check if the grid voltage is too high.</li> <li>2. Check if the inverter AC output cable connections are secure and if the grid-tie cable is too thin.</li> <li>3. Check if the inverter grid compliance specifications are selected correctly.</li> </ol>
62	Slave Phase1 Voltage Low	Grid voltage below the safety permissible range of the inverter	<ol style="list-style-type: none"> <li>1. Check if the grid voltage is too low.</li> <li>2. Check if the inverter AC output cable connections are secure.</li> <li>3. Check if the inverter grid compliance specifications are selected correctly.</li> </ol>
63	Slave Phase2 Voltage High	Grid voltage exceeds the safety permissible range of the inverter	<ol style="list-style-type: none"> <li>1. Check if the grid voltage is too high.</li> <li>2. Check if the inverter AC output cable connections are secure and if the grid-tie cable is too thin.</li> <li>3. Check if the inverter grid compliance specifications are selected correctly.</li> </ol>
64	Slave Phase2 Voltage Low	Grid voltage below the safety permissible range of the inverter	<ol style="list-style-type: none"> <li>1. Check if the grid voltage is too low.</li> <li>2. Check if the inverter AC output cable connections are secure.</li> <li>3. Check if the inverter grid compliance specifications are selected correctly.</li> </ol>
65	Slave Phase3 Voltage High	Grid voltage exceeds the safety permissible range of the inverter	<ol style="list-style-type: none"> <li>1. Check if the grid voltage is too high.</li> <li>2. Check if the inverter AC output cable connections are secure and if the grid-tie cable is too thin.</li> <li>3. Check if the inverter grid compliance specifications are selected correctly.</li> </ol>
66	Slave Phase3 Voltage Low	Grid voltage below the safety permissible range of the inverter	<ol style="list-style-type: none"> <li>1. Check if the grid voltage is too low.</li> <li>2. Check if the inverter AC output cable connections are secure.</li> <li>3. Check if the inverter grid compliance specifications are selected correctly.</li> </ol>
67	Slave Frequency High	Grid frequency exceeds local grid upper limit	<ol style="list-style-type: none"> <li>1. Check if the inverter grid compliance specifications are selected correctly.</li> <li>2. Disconnect AC and DC switches for 5 minutes, then restart the inverter.</li> </ol>
68	Slave Frequency Low	Grid frequency below local grid lower limit	
69	DCDC_Lost.Conn Warn	Communication loss between DCDC device and inverter	Contact the installer.
70	DCDC_Device Error	DCDC device fault	
71	Parall CAN Lost Com. Err	Number of online slave units read by parallel host does not match configured parallel number	<ol style="list-style-type: none"> <li>1. Check if the slave ID settings are correct.</li> <li>2. Check if the parallel CAN communication cable is properly connected.</li> </ol>
72	LCD Lost comm.Err	Inverter does not receive communication data from LCD	Check if the communication cable between the LCD and the inverter is properly connected.
73	Slave No Grid Error	Inverter cannot detect grid voltage	<ol style="list-style-type: none"> <li>1. Confirm whether the grid is powered off, check if the grid-tie box switch has tripped and ensure the inverter AC cables are securely connected.</li> </ol>

			2. If there is no power outage, disconnection, or loose connections after the above checks, close the AC switch and reconnect to the grid.
76	Slave PV Voltage High	DC input voltage of the inverter is too high	1. Check the number of panels in each string, calculate whether the open-circuit voltage of the string exceeds the maximum input voltage of the inverter. 2. If the above checks confirm no issues, close the AC switch and restart the inverter.
78	Grid Power Emergency Disconnect	Grid AC relay disconnects based on external device command	Contact the installer.
81	Lost Communication D<->C	Internal communication loss in inverter	Disconnect AC and DC switches for 5 minutes, then restart the inverter.
83	Master Arc Device Error	Arc fault device failure	Contact the installer or SAJ Electric service hotline.
84	Master PV Mode Error	PV mode selection error	1. Check whether the inverter string mode is set correctly 2. If the fault persists after resolving the above, contact the installer or SAJ Electric service hotline.
85	Authority expires	Authorization expired	Contact the installer or SAJ Electric service hotline.
86	DRMO Error	DRMO fault	Contact the installer or SAJ Electric service hotline.
87	Master Arc Error	DC arcing caused by short circuit or poor terminal contact	1. Check if all terminals are properly connected and whether the PV positive/negative insulation to ground is normal. 2. If the above checks confirm no issues, close the AC switch and restart the inverter.
88	Master SW PV Current High	1. PV string positive and negative poles are reversed 2. Inverter internal damage	1. Check whether the positive and negative poles of the string are reversed. 2. If the above checks confirm no issues, close the AC switch and restart the inverter.
89	Master Battery Voltage High	Battery voltage too high	Battery voltage is higher than the maximum voltage value of the inverter.
90	Master Battery Current High	Battery SOC too low or load too heavy, preventing battery output	1. Reduce the back-up load. 2. Charge the battery or stop using the battery. 3. If the battery charge and load are normal but the fault persists, contact the installer or SAJ Electric service hotline.
91	Master Battery Charge Voltage High	Battery voltage too high during charging	1. Do not turn off the battery during charging. 2. Restart the battery and inverter.
92	Master Battery OverLoad	Battery SOC too low or load too heavy, preventing battery output	1. Reduce the back-up load. 2. Charge the battery or stop using the battery. 3. If the battery charge and load are normal but the fault persists, contact the installer or SAJ Electric service hotline.
93	Master Battery SoftConnet TimeOut	Battery pre-charging bus failure	Contact the installer or SAJ Electric service hotline.

94	Master Output OverLoad	Load connected to back-up port exceeds H2 maximum output power	Reduce the load connected to the back-up port.
95	Master Battery Open Circuit Error	Inverter cannot detect battery voltage	<ol style="list-style-type: none"> <li>1. Check if the battery circuit breaker is turned on.</li> <li>2. Check if the battery power cable connections are secure.</li> </ol>
96	Master Battery Discharge Voltage Low	Voltage too low detected during battery discharge overload	<ol style="list-style-type: none"> <li>1. Do not turn off the battery during discharge.</li> <li>2. The battery voltage is too low, system protection.</li> </ol>
97	BMS Internal Communication Error	<ol style="list-style-type: none"> <li>1. Communication abnormality between battery high-voltage box and battery pack</li> <li>2. The last battery pack not connected with a resistor terminator causing abnormal pack quantity recognition by the high-voltage box</li> </ol>	<ol style="list-style-type: none"> <li>1. Check if the communication cable is abnormal.</li> <li>2. Check if the last battery pack has a terminator connected.</li> </ol>
98	Bat Sequence Error	Battery pack communication abnormality	<ol style="list-style-type: none"> <li>1. Check if the communication cable wiring is correct.</li> <li>2. Check if the last battery pack has a terminator connected</li> <li>3. Check if the communication cable is abnormal.</li> </ol>
99	Discharge Over Current Protect	Discharge current exceeds set threshold	Wait for the fault to clear or restart.
100	Charge Over Current Protect	Charge current exceeds set threshold	Wait for the fault to clear or restart.
101	Module Under Voltage Protect	Total voltage below set threshold	Force charge the battery.
102	Module Over Voltage Protect	Total voltage above set threshold	Wait for the fault to clear or restart.
103	Single Cell Under Voltage Protect	Cell voltage below minimum set value	Force charge the battery.
104	Single Cell Over Voltage Protect	Cell voltage above set threshold	Wait for the fault to clear or restart.
105	BMS Hardware Error	<ol style="list-style-type: none"> <li>1. Cell voltage detection module fault</li> <li>2. Temperature detection module fault</li> <li>3. Current detection module fault</li> </ol>	If the fault persists after restarting, contact the installer.
106	Charge Cell Under Temperature Protect	Battery charging below 0°C	Wait for the battery temperature to rise until the fault clears.
107	Charge Cell Over Temperature Protect	Battery temperature too high	Wait for the battery temperature to drop until the fault clears.
108	Discharge Cell Under Temperature Protect	Battery temperature too low, relay disconnects to stop discharge	Wait for the battery temperature to rise until the fault clears.

109	Discharge Cell Over Temperature Protect	Battery temperature too high	Wait for the battery temperature to drop until the fault clears.
110	Relay Error	1. Negative or positive relay stuck 2. Negative or positive relay unable to close	If the fault persists after restarting, contact the installer.
111	Pre-charge Error	1. Pre-charge relay damaged 2. Pre-charge resistor open circuit 3. BMS damaged	
112	Insulation Error	Possible leakage current issue in battery pack	
113	BMS supplier Incompatibility	BMS mismatch between battery pack and high-voltage box	Contact the installer.
114	Battery cell supplier Incompatibility	Inconsistent cell manufacturers within battery pack	
115	Battery cell Incompatibility	Inconsistent cell grades within battery pack	
116	Battery pack models or grades are inconsistent	Battery pack model or grade mismatch	
117	Circuit Breaker Is Open	1. Battery circuit breaker not closed 2. Battery circuit breaker auxiliary contact abnormality	Close the battery circuit breaker.
118	Temperature Difference Is Too Wide	Temperature detection module fault	If the fault persists after restarting, contact the installer.
119	Voltage Difference Is Too Wide	Sampling wire loose	
120	Voltage Difference Is Too Wide	Sampling wire loose	
121	BMS Over Temperature Protect	1. Ambient temperature too high 2. Battery overload	1. Check if the battery ambient temperature is too high. 2. If the temperature is normal, let the battery rest for 30 minutes and restart.
122	Short Circuit Protect	Short circuit between battery positive and negative terminals	Check if the battery wiring is correct.
123	Total voltage match failed	Contact technical personnel to troubleshoot the issue	Contact the installer.
124	The system is locked	Contact technical personnel to troubleshoot the issue	
125	FUSE error protection	Contact technical personnel to troubleshoot the issue	
126	Battery Port Voltage Abnormal Protection	Contact technical personnel to troubleshoot the issue	
127	Heating Film Overtemperature Protection	Contact technical personnel to troubleshoot the issue	Contact the installer.

128	Abnormal Temperature Increases	Contact technical personnel to troubleshoot the issue	
162	Gen Start or Stop Error	Check the connection between the generator and the inverter	
289	Relay over temperature	Charging pile internal status abnormal Relay temperature consistently above 115°C causing fault	<ol style="list-style-type: none"> <li>1. Reduce current output, stop charging and let it cool down before attempting to charge again.</li> <li>2. If the fault occurs again, contact the installer.</li> </ol>
290	Overload	Contact technical personnel to troubleshoot the issue	Contact the installer.
291	AC over voltage	Grid voltage at pile input exceeds 276V, or does not recover below 265V after overvoltage	<ol style="list-style-type: none"> <li>1. Normally, the charging pile fault will clear automatically after the grid returns to normal. If the fault recurs: measure the actual grid voltage.</li> <li>2. If the grid voltage is indeed higher than 265V, contact the local power company for resolution.</li> </ol>
292	AC under voltage	Grid voltage at pile input below 184V, or does not recover above 196V after undervoltage	<ol style="list-style-type: none"> <li>1. Normally, the charging pile fault will clear automatically after the grid returns to normal. If the fault recurs: measure the actual grid voltage.</li> <li>2. If the grid voltage is indeed lower than 196V, contact the local power company for resolution.</li> <li>3. Check if the charging pile AC wiring is tight.</li> </ol>
293	AC over current	Output current value exceeds 18A	<ol style="list-style-type: none"> <li>1. Stop charging, unplug the charging gun, wait for the charging pile fault status to clear, then try charging again.</li> <li>2. If the fault recurs, contact the vehicle manufacturer's after-sales service.</li> <li>3. Stop charging, unplug the charging gun.</li> </ol>
294	AC over frequency	Mains AC frequency exceeds 63Hz, or does not recover below 61Hz after over frequency	<ol style="list-style-type: none"> <li>1. Normally, the charging pile fault will clear automatically after the grid returns to normal. If the fault recurs: measure the actual grid frequency.</li> <li>2. If the grid frequency is indeed higher than 61Hz, contact the local power company for resolution.</li> </ol>
295	AC under frequency	Mains AC frequency below 47Hz, or does not recover above 49Hz after under frequency	<ol style="list-style-type: none"> <li>1. Normally, the charging pile fault will clear automatically after the grid returns to normal. If the fault recurs: measure the actual grid frequency.</li> <li>2. If the grid frequency is indeed lower than 49Hz, contact the local power company for resolution.</li> </ol>
296	DC residual current exception A	Save one point every 20ms, fault reported if 3 consecutive points exceed 50mA (60~80ms) DC leakage current greater than 6mA (reaction time 10s)	<ol style="list-style-type: none"> <li>1. Stop charging, unplug the charging gun, wait for the charging pile fault status to clear, then try charging again.</li> <li>2. If the fault recurs, contact the vehicle manufacturer's after-sales service.</li> <li>3. Stop charging, unplug the charging gun.</li> <li>4. If the charging pile remains in a fault state, contact the installer.</li> </ol>
297	Emergency Stop	User mistakenly pressed emergency stop button	Reset the emergency stop button.
298	Under temperature	Contact technical personnel to troubleshoot the issue	Contact the installer.

299	AC residual current	RCD residual current device circuit abnormal (During pile self-test, leakage current not within 5~20mA for 10 consecutive seconds)	<ol style="list-style-type: none"> <li>Restart the device after power off and try charging again.</li> <li>If the fault occurs again, contact the installer.</li> </ol>
300	Input terminal over temperature	Loose input terminal wiring, poor contact Selected cable ampacity does not meet requirements	Check if the charging pile AC wiring is tight and if the cable cross-section meets requirements.
301	Bluetooth fault	Contact technical personnel to troubleshoot the issue	Contact the installer.
302	DC residual current exception B	Save one point every 60ms, fault reported if 3 consecutive points exceed 36mA (180~240ms) DC leakage current greater than 6mA (reaction time 10s)	<ol style="list-style-type: none"> <li>Stop charging, unplug the charging gun, wait for the charging pile fault status to clear, then try charging again.</li> <li>If the fault recurs, contact the vehicle manufacturer's after-sales service.</li> <li>Stop charging, unplug the charging gun.</li> <li>If the charging pile remains in a fault state, contact the installer.</li> </ol>
303	Relay exception	After plugging in gun, relay detected stuck 3 times consecutively and unable to disconnect (auto-closing)	<ol style="list-style-type: none"> <li>Restart the device after power off and try charging again</li> <li>If the fault occurs again, contact the installer.</li> </ol>
304	Grounding error	Voltage between GND and N greater than 36V alarm, does not affect charging	<ol style="list-style-type: none"> <li>Check the voltage between the N wire and PE wire at the charging pile input.</li> <li>If the voltage is greater than 36V, check if the equipment ground wire is loose and ensure good grounding.</li> </ol>
305	Phase twisted	Input L and N reversed	Check if the L and N wire sequence of the charging pile input cable is correct.
306	RCD circuit exception	RCD residual current device circuit abnormal (During pile self-test, leakage current not within 5~20mA for 10 consecutive seconds)	<ol style="list-style-type: none"> <li>Restart the device after power off and try charging again.</li> <li>If the fault occurs, contact the installer.</li> </ol>
307	RS485 Com time out	<ol style="list-style-type: none"> <li>Wiring issue</li> <li>Backend has update, unable to communicate</li> </ol>	<ol style="list-style-type: none"> <li>Check wiring issues, open the cover and reconnect.</li> <li>If the problem cannot be resolved, contact the installer.</li> </ol>
308	Electricity exception	Contact technical personnel to troubleshoot the issue	Contact the installer.
311	Meter fault	Contact technical personnel to troubleshoot the issue	
312	cp exception, cp lower than 2V	CP voltage below 2V	<ol style="list-style-type: none"> <li>Restart the device after power off and try charging again.</li> <li>If the fault occurs again, contact the installer.</li> </ol>
318	Connector lock exception	<ol style="list-style-type: none"> <li>Foreign objects may block gun lock</li> <li>Gun not plugged in properly</li> </ol>	<ol style="list-style-type: none"> <li>Open the cover for inspection, remove any foreign objects.</li> <li>Plug the gun in properly.</li> </ol>

319	Connector current exception	Gun cable specification issue	Contact the installer.
320	DC residual current exception C	Contact technical personnel to troubleshoot the issue	

# 10.

## **PRODUCT SPECIFICATIONS**



Model	H2-3K-LS2-S	H2-3.6K-LS2-S	H2-4K-LS2-S	H2-4.6K-LS2-S	H2-5K-LS2-S	H2-6K-LS2-S
<b>PV String</b>						
Max. PV Array Power [Wp]@STC	6000	7000	8000	9200	10000	12000
Max. PV Input Power [W]	4800	5760	6400	7360	8000	9600
Max. PV Input Voltage [V]	500					
Rated PV Input Voltage [V]	360					
MPPT Voltage Range [V]	80-450					
Start-up Voltage [V]	80					
Max. DC Input Current [A]	18/18					
Max. DC Short Circuit Current [A]	25/25					
Quantity Of MPPT	2/2					
<b>Battery</b>						
Battery Type	Lead-acid or LiFePO4					
Battery Voltage Range [V]	40-60					
Max. Charging / Discharging Current [A]	80	90	100	110	120	140
Charging strategy for Li-ion battery	Self-adaption to BMS					
Communication	CAN					
<b>AC Output [On-grid]</b>						
Rated AC Power [W]	3000	3600	4000	4600	5000	6000
Max. Apparent Power [VA]	3300	3600	4400	4600	5500	6600
Rated Output Current [A]	13.0	15.7	17.4	20.0	21.7	26.1
Max. Output Current [A]	14.3	15.7	19.1	20.0	23.9	28.7

Model	H2-3K-LS2-S	H2-3.6K-LS2-S	H2-4K-LS2-S	H2-4.6K-LS2-S	H2-5K-LS2-S	H2-6K-LS2-S
Rated AC Voltage / Range [V]	L+N+PE, 220,230,240					
Rated Output Frequency / Range [Hz]	50 Hz: 45-55 Hz / 60 Hz: 55-65 Hz					
Power Factor Adjustment Range [Cos $\Phi$ ]	0.8 leading-0.8 lagging					
Total Harmonic Distortion [Thdi]	< 3%					
<b>AC Input [On-gird]</b>						
Rated AC Voltage / Range [V]	L+N+PE, 220,230,240 / 180-280					
Rated Input Frequency [Hz]	50 / 60					
AC Bypass Current [A]	63					
<b>AC Output [Back-up]</b>						
Max. Output Power [VA]	3000	3600	4000	4600	5000	6000
Max. Output Current [A]	13.0	15.7	17.4	20.0	21.7	26.1
Peak Output Apparent Power [VA]	2 times of rated output power, 10 s					
Rated AC Voltage / Range [V]	L+N+PE, 220,230,240					
Rated Output Frequency / Range [Hz]	50 Hz: 45-55 Hz / 60 Hz: 55-65 Hz					
Total Harmonic Distortion [Thdv] (@ Linear Load)	< 3%					
<b>Efficiency</b>						
Max. Efficiency	97.6%					
Euro. Efficiency	97.0%					
<b>Protection</b>						

Model	H2-3K-LS2-S	H2-3.6K-LS2-S	H2-4K-LS2-S	H2-4.6K-LS2-S	H2-5K-LS2-S	H2-6K-LS2-S
Battery Input Reverse Polarity Protection	Integrated					
Overload Protection	Integrated					
AC Short Circuit Current Protection	Integrated					
DC Surge Protection	Type II					
AC Surge Protection	Type II					
Anti-islanding Protection	Integrated					
AFCI Protection	Integrated					
RSD Protection	Integrated					
<b>Interface</b>						
PV Connection	MC4					
AC Connection	Terminal block					
Battery Connection	Terminal block					
Display Screen	LCD + App					
Communication	Wi-Fi / Ethernet / 4G (Optional)					
<b>General parameters</b>						
Topology	Non-isolated					
Ingress protection rating	IP66					
Operating temperature range	-40°C to +60°C / -40 °F to +140°F (Derating: +45 °C to 60°C)					
Cooling method	Nature cooling					
Operating Humidity	0%–100% RH, no condensation					
Operating Altitude [m]	3000					
Noise [dBA]	< 35					

Model	H2-3K-LS2-S	H2-3.6K-LS2-S	H2-4K-LS2-S	H2-4.6K-LS2-S	H2-5K-LS2-S	H2-6K-LS2-S
Dimension [H x W x D]	460 x 350 x 231 mm					
Weight	24 kg					
Warranty [year]	5-10					
Applicable Standard	EN 62109-1/2, EN 61000-6-2/4, IEC 62116, IEC 61727, PEA&MEA, NBR 16149, NBR 16150, PORTARIA No. 140					

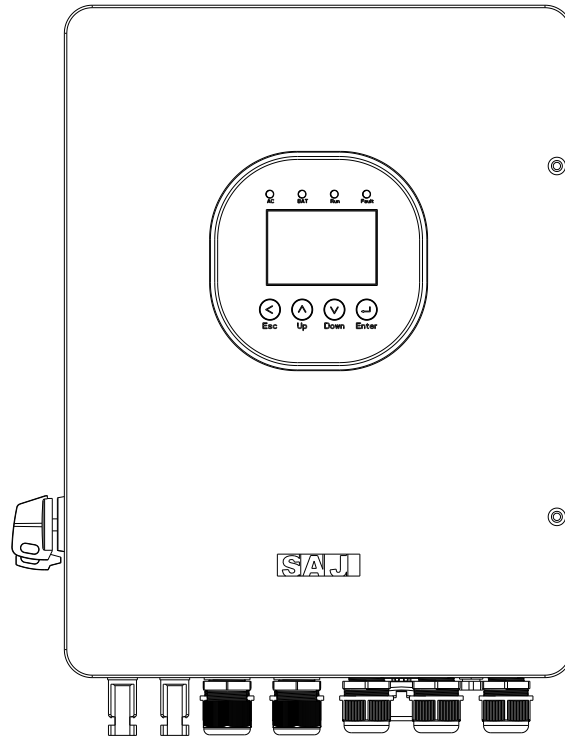

11.

**APPENDIX**



## 11.1. Recycling and disposal

This device should not be disposed of as residential waste.

An inverter that has reached the end of its operation life is not required to be returned to your dealer; instead, it must be disposed of by an approved collection and recycling facility in your area.

## 11.2. Warranty

Check the product warranty conditions and terms on the SAJ website: <https://www.saj-electric.com/>

## 11.3. Contacting support

### Online technical support

Go to <https://www.saj-electric.com/services-support-technical> to check FAQs or send your message or product enquiry.

### Call for assistance

For SAJ support telephone numbers, see <https://www.saj-electric.com/locations> for your region support details.

### Head Quarter

Guangzhou Sanjing Electric Co., Ltd.

Address: SAJ Innovation Park, No.9, Lizhishan Road, Guangzhou Science City, Guangdong, P.R.China.

Tel: +86 20 6660 8588

E-mail: [service@saj-electric.com](mailto:service@saj-electric.com)

Website: <https://www.saj-electric.com/>

## 11.4. Trademark

SAJ is the trademark of SanJing.

# SAJ



**GUANGZHOU SANJING ELECTRIC CO., LTD**

**Tel:** 86-20-66608588 **Fax:** 86-20-66608589 **Web:** [www.saj-electric.com](http://www.saj-electric.com)  
**Add:** SAJ Innovation Park, No.9, Lizhishan Road, Science City, Guangzhou High-tech Zone, Guangdong, P.R.China

V0