

SAJI

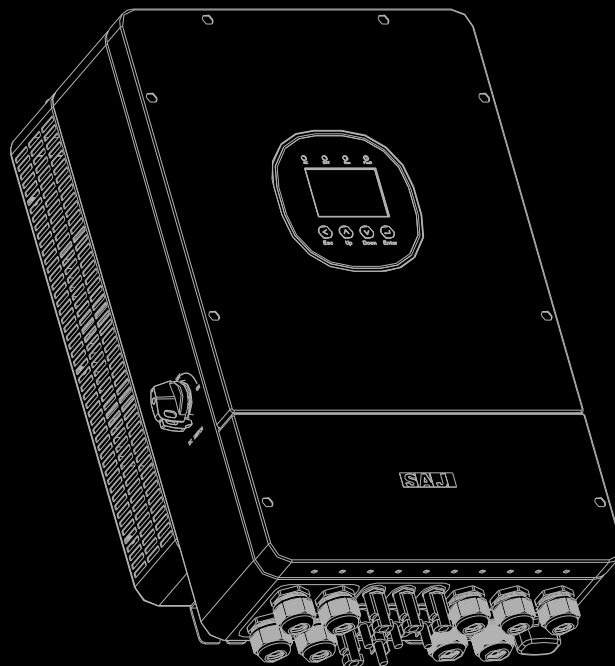

H2 Series

**HYBRID INVERTER
USER MANUAL**

H2-(5K-12K)-LS2

Preface

Thank you for choosing SAJ products. We are pleased to provide you with first-class products and exceptional service.

This manual provides information about installation, operation, maintenance, troubleshooting and safety. Please follow the instructions of this manual so that we can ensure delivery of our professional guidance and whole-hearted service.

Customer-orientation is our forever commitment. We hope this document proves to be of great assistance in your journey for a cleaner and greener world.

We make constant improvements on the products and their documentation. This manual is subject to change without notice; these changes will be incorporated in new editions of the publication. To access the latest documentation, visit the SAJ website at <https://www.saj-electric.com/>.

Guangzhou Sanjing Electric Co., Ltd.



TABLE OF CONTENTS

1. SAFETY PRECAUTIONS.....	1
1.1. About this document	2
1.1.1. Overview	2
1.1.2. Target audience.....	2
1.2. Safety.....	3
1.2.1 Safety levels	3
1.2.2. Safety symbols.....	3
1.2.3. Safety instructions.....	4
2. PRODUCT INFORMATION.....	7
2.1. General introduction	8
2.2. Model description	11
2.2.1. Product models	11
2.2.2. Model description.....	11
2.3. Dimension	11
2.4. Bottom view	12
2.5. Electrical terminals.....	13
2.6. LCD indicators.....	14
3. TRANSPORTATION AND STORAGE.....	15
3.1. Transportation.....	16
3.2. Storage.....	17
4. INSTALLATION.....	19
4.1. Precautions	20
4.2. Installation diagram.....	20

4.3. Choose installation site	22
4.3.1. Installation environment requirements	22
4.3.2. Installation position requirements	23
4.4. Prepare installation tools	24
4.5. Unpacking	25
4.5.1. Check the outer packing	25
4.5.2. Check the package contents	25
4.6. Install the inverter	26
4.7. Install the battery	28
5. ELECTRICAL CONNECTION	29
5.1. Safety instructions	30
5.2. System connection and recommended cable list	30
5.3. Connect the grounding cable	35
5.4. Open the junction box of the inverter	36
5.5. Connect the battery to the inverter	37
5.6. Assemble the communication connection	39
5.6.1. Install the communication module	39
5.6.2. Connect the battery temperature sensor (for lead-acid batteries)	40
5.6.3. Connect the RJ45 ports	41
5.6.3.1. DRM connection	43
5.6.3.2. Parallel connection	44
5.6.3.3. BMS connection	45
5.6.3.4. Smart meter connection	46
5.6.4. Connect the communication port	48
5.7. Assemble the AC-side electrical connection	49
5.8. Assemble the PV-side electrical connection	52
5.9. Close the junction box of the inverter	55
6. STARTUP AND SHUTDOWN	57
6.1. Startup	58
6.2. Shutdown	59

6.3. Emergency shutdown	59
6.4. Restart after emergency shutdown	59
7. COMMISSIONING ON THE APP	61
7.1. Download the App	62
7.2. Log in to the App	62
7.3. Perform the initialization settings	64
7.4. Configure the communication module	79
7.5. Create a plant	80
7.6. View the fixed power factor mode and fixed reactive power mode	82
8. COMMISSIONING ON THE LCD	83
8.1. Operations on the main screen	84
8.2. Settings	86
8.2.1. Initialization setting	87
8.2.2. Battery setting	88
8.2.3. Advanced settings	89
8.2.3.1. Zero export	89
8.2.3.2. Parallel settings	89
8.2.3.3. AFCI settings (optional)	90
8.2.3.4. GEN port settings	90
8.2.3.5. MicroInv Settings	91
8.2.3.6. Smartload settings	91
8.2.3.7. Diesel generator port	92
8.2.3.8. Protection parameters	93
8.2.3.9. Feature parameters	94
8.2.3.10. Power adjustment	97
8.2.3.11. CT-DIR correction	97
8.2.4. Device setting	98
8.2.5. Equipment information	98
9. Troubleshooting	99
10. Product specifications	113

11. Appendix.....	错误!未定义书签。
11.1. Recycling and disposal	120
11.2. Warranty	120
11.3. Contacting support	120
11.4. Trademark	120

1.

**SAFETY
PRECAUTIONS**



⚠ DANGER

- Before installing, using, or maintaining this equipment, read the safety precautions thoroughly, and comply with them during operations.
- Failure to follow any of the instructions and warnings in this document may result in electrical shock, serious injury, or death, and may damage the equipment, potentially rendering it inoperable. SAJ shall not be held responsible for any personal injuries or property damage caused by improper use.

1.1. About this document

1.1.1. Overview

This user manual describes instructions and detailed procedures for installing, operating, maintaining, and troubleshooting the following SAJ inverters:

H2-5K-LS2

H2-6K-L2

H2-7.6K-LS2

H2-8K-LS2

H2-10K-LS2

H2-12K-LS2

Please read this manual carefully before installations and operations. Always keep this manual available in case of emergency and maintenance purposes.

1.1.2. Target audience

This manual is intended for qualified personnel who need to install, operate, maintain, and troubleshoot inverters and related system components. Qualified personnel should have the necessary training, knowledge, and experience in:

- Installing electrical equipment.
- Applying all applicable installation tools.
- Analyzing and reducing hazards involved in electrical work.
- Installing and configuring batteries.
- Selecting and using Personal Protective Equipment (PPE).

Battery service must only be performed or supervised by qualified personnel with knowledge of batteries and their required precautions.

1.2. Safety

CAUTION

- Only qualified and trained electricians who have read and fully understood the safety regulations in this manual may install, maintain, or repair the equipment.
- Access to the equipment requires the use of a tool, lock, and key, or other security measures.

1.2.1. Safety levels

DANGER

DANGER indicates a hazardous situation which, if not avoided, will result in death or serious injury.

WARNING

WARNING indicates a hazardous situation which, if not avoided, will result in serious or moderate injury.



CAUTION









CAUTION indicates a hazardous situation which, if not avoided, will result in minor or moderate injury.

NOTICE

NOTICE indicates a situation which, if not avoided, will result in potential damage.

1.2.2. Safety symbols

Symbol	Description
	DANGER: Electric Shock Hazard This device is connected directly to the public grid. Failure to follow the warnings in this manual could result in severe electric shock.
	DANGER: Hot Surface The components inside the inverter battery will release a lot of heat during operation. Do not touch metal plate housing during operating.

	WARNING: No Open Flames Maintain a safe distance from all flammable and explosive materials.
	CAUTION: Wait For 5 Minutes Risk of electric shock from energy stored in capacitor. Do not remove cover until 5 minutes after disconnecting all sources of supply.
	NOTICE: Keep Away from Children Install the product out of reach of children.
	NOTICE: Consult Manual Before Servicing Check the user manual before servicing. If an error has occurred, refer to the troubleshooting chapter to remedy the error.
	NOTICE: Dispose of Device Properly This device shall NOT be disposed of in residential waste.
	NOTICE: Dispose of Battery Properly This battery module shall NOT be disposed of in residential waste.
	CE mark Equipment with the CE mark fulfills the requirements of the Low Voltage Directive (2014/35/EU) and Electro Magnetic Compatibility (2014/30/EU).
	RoHS compliant mark Equipment with the RoHS mark does not exceed the allowable amounts of the restricted substances defined in Restriction of Hazardous Substances in Electrical and Electronic Equipment.
	Recyclable

1.2.3. Safety instructions

For your safety, read all safety instructions before beginning any work, and ensure all procedures comply with local and national regulations.

 **DANGER**

- Risk of fatal personnel injuries due to electrical shock and high voltage.
- Do not touch the operating component of the inverter; it might result in burning or death.
- To prevent the risk of electric shock during installation and maintenance, make sure that all AC and DC terminals are disconnected prior to work.
- Do not touch the surface of the inverter while the housing is wet, otherwise, it might cause electrical shock.
- Do not stay close to the inverter while there are severe weather conditions including storms, lightning, etc.
- Before opening the housing, the inverter must be disconnected from the grid and PV array; wait for at least five minutes to let the energy storage capacitors completely discharge after disconnecting from power source.
- Please keep the power off prior to any operations.

 **WARNING**

- Any unauthorized actions including modification of product functionality of any form may cause lethal hazard to the operator, third parties, the units or their property. SAJ shall not be held responsible for the loss and these warranty claims.
- Do not touch non-insulated parts or cables.
- For personal and property safety, do not short-circuit the positive (+) and negative (-) electrode terminals.
- Disconnect the PV array from the inverter by using an external disconnection device. If no external disconnection device is available, wait until no more DC power is applied to the inverter.
- Disconnect the AC circuit breaker, or keep it disconnect if it is tripped, and secure it against reconnection.

 **CAUTION**

- Risk of damage due to improper modifications.

 **NOTICE**

- Make sure the AC input voltage and current are compatible with the rated voltage and current of the inverter; otherwise, components might be damaged, or the device cannot work properly.
- Moving or reinstalling the inverter to another location might void the warranty without prior written permission from SAJ.

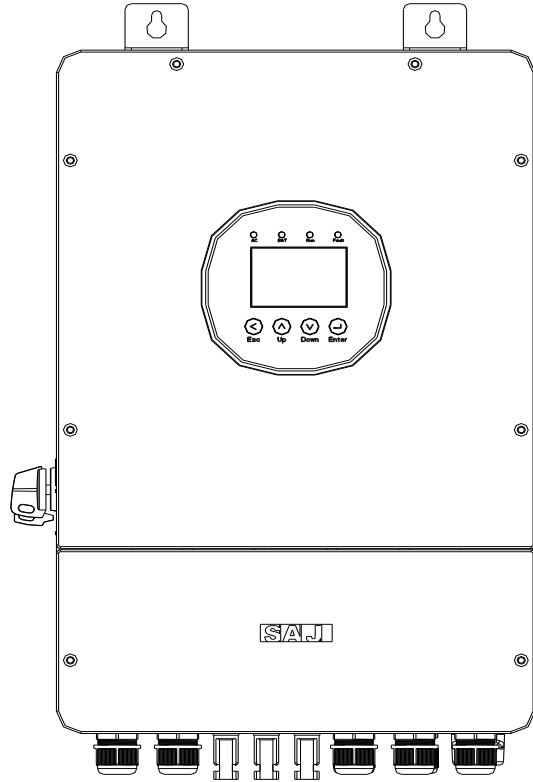

2.

PRODUCT INFORMATION



2.1. General introduction

The H2 series is a transformer-less, low-voltage hybrid solar inverter and serves as a core component in energy storage systems.

The H2 inverter provides the following features:

- The inverter integrates maximum power point tracking (MPPT), battery charging/discharging circuit and full-bridge inverting circuit.
- The inverter converts solar power to grid-compliant AC power for home loads and sells extra power to the grid. The solar power can also be stored into the battery for later use during grid failures or peak electricity price periods.
- When power outage occurs, the inverter seamlessly switches critical loads to battery power without supply interruption.

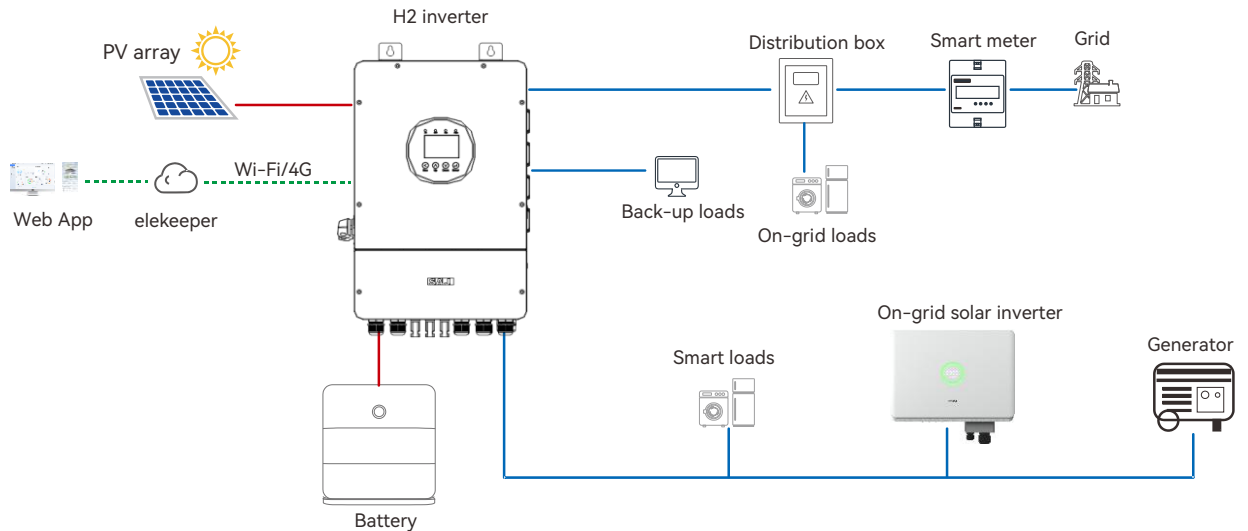

Figure 2.1 Application topology

2.2. Working modes

The H2 inverter offers three working modes to suit different user needs and environments, including Self-consumption Mode, Time-of-use Mode, and Back-up Mode.

2.2.1. Self-consumption mode

Self-consumption mode is the basic working mode. It maximizes the use of electricity generated by PV and minimizes the electricity purchased from the grid to reduce costs.

Period	Working logic
PV power is sufficient	PV → Loads > Battery > Grid In this case, any power generated by the PV will first be supplied to the loads, with any surplus being used to charge the battery. Any excess power can then be exported to the grid.
PV power is insufficient	PV + Battery + Grid → Loads In this case, both the PV and the battery power the loads. When PV power is insufficient, the battery discharges power to the loads. Once the battery reaches its minimum SOC, it stops discharging, and the grid supplies power to the loads.

2.2.2. Time-of-use mode

Time-of-use mode allows users to set the charging and discharging time of the battery. Users can set the charging and discharging time according to the local peak and valley electricity price to reduce costs.

Period	Working logic
Charging period	Grid → Battery During a period of low electricity price, the battery charges from the grid at a preset charging power until reaching the preset stop-charging SOC (%).
Discharging period	Battery → Loads + Grid During a period of high electricity price, the battery discharges to loads or the grid at a preset discharging power until reaching the preset stop-discharging SOC (%).
Other period	The working logic is the same as self-consumption mode.

2.2.3. Back-up mode

Back-up mode is suitable for areas with frequent power outages. In this mode, the battery capacity is maintained at a relatively high level to ensure that loads work normally when the grid is off.

Note: The battery will not be discharged until a grid outage occurs.

Period		Working logic	
PV power is sufficient	Grid outage occurs	<ul style="list-style-type: none"> If a grid outage occurs, the power generated by the PV will first be supplied to the loads, with any surplus being used to charge the battery. [PV → Loads > Battery] 	
	No grid outage	<ul style="list-style-type: none"> If the grid works normally, the PV will supply the loads first and any surplus will be used to charge the battery. Excess power can then be exported to the grid. [PV → Loads > Battery > Grid] 	
PV power is insufficient	Battery SOC > preset capacity	Grid outage occurs	<ul style="list-style-type: none"> If a grid outage occurs and the PV power is insufficient, the battery discharges power to the loads. Once the battery reaches its minimum SOC, it stops discharging. [Battery → Loads]
		No grid outage	<ul style="list-style-type: none"> If the grid works normally and the PV power is insufficient, the grid powers the loads. [Grid → Loads]
	Battery SOC ≤ preset capacity	Grid outage occurs	<ul style="list-style-type: none"> If a grid outage occurs, and the battery SOC is lower than the preset capacity, only the insufficient PV supplies power to the loads. The battery will not be discharged until its SOC becomes larger than the preset capacity. [Insufficient PV → Loads]
		No grid outage	<ul style="list-style-type: none"> If the grid works normally, the battery SOC is lower than the preset capacity, and the PV power is insufficient, only grid powers the loads. [Grid → Loads]

2.3. Model description

2.3.1. Product models

The H2 series low-voltage single-phase inverter is available in the following models:

- H2-5K-LS2
- H2-6K-LS2
- H2-7.6K-LS2
- H2-8K-LS2
- H2-10K-LS2
- H2-12K-LS2

2.3.2. Model description

H2 - xK - LS2

H2: Inverter series.

xK: Rated power of the inverter. For example, 5K indicates the rated power of the inverter is 5 kW.

LS2: Low-voltage, single-phase inverter with 2 MPPT.

2.4. Dimension

Dimension (H x W x D): 588 x 378 x 239 mm (18.11 x 13.78 x 9.09 inches)

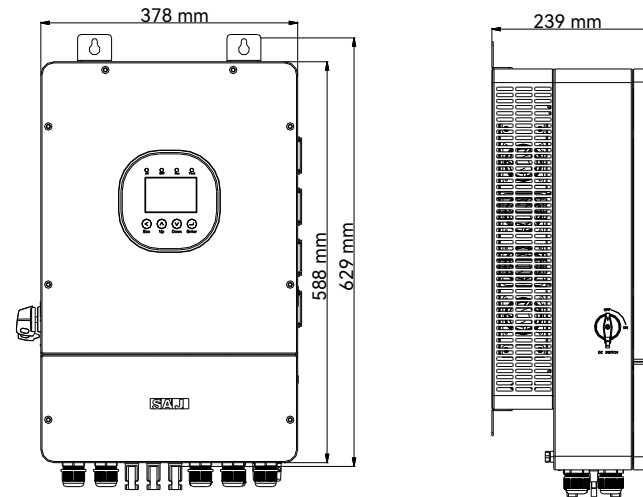

Figure 2.2 Inverter dimension

2.5. Bottom view

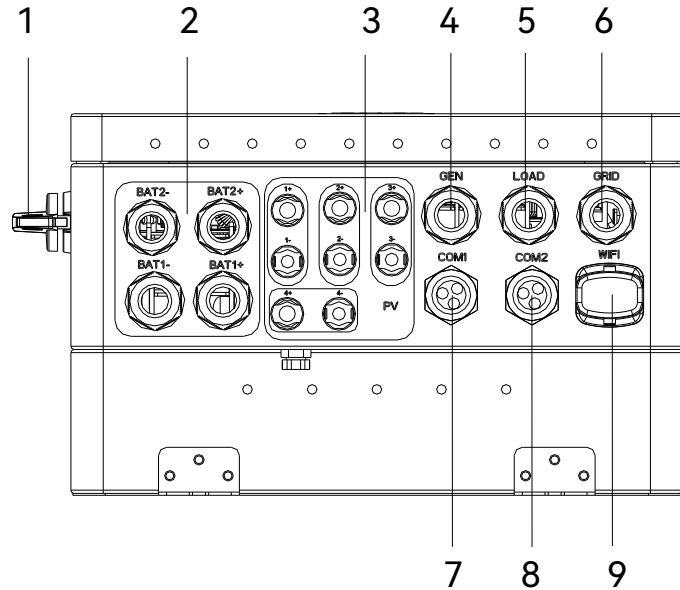

Figure 2.3 Bottom view of the inverter

Callout	Silkscreen	Description
1	DC Switch	DC switch which controls the PV connection.
2	BAT 1-/1+/2-/2+	Cable gland for battery positive and negative cables 1 and 2.
3	PV 1+/1-/2+/2- /3+/3-/4+/4-	DC input terminals.
4	GEN	Cable gland for generator cables connecting to terminals GEN-L, GEN-N, and GEN-PE.
5	LOAD	Cable gland for load cables connecting to terminals LOAD-L, LOAD-N, and LOAD-PE.
6	GRID	Cable gland for grid cables connecting to terminals GRID-L, GRID-N and GRID-PE.
7	COM1	Cable gland for communication cables connecting to communication port block.
8	COM2	Cable gland for communication cables connecting to RJ45 communication port.
9	WIFI	Wi-Fi port for connecting the communication module.

Table 2.1. Description of bottom-view silkscreen

2.6. Electrical terminals

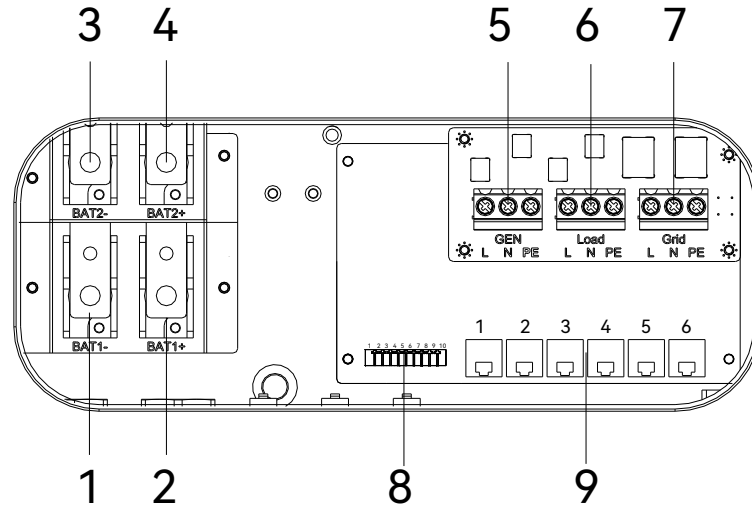

Figure 2.4 Electrical terminals in the junction box

Callout	Silkscreen	Description
1	BAT1-	Terminals for connecting battery negative cable 1.
2	BAT1+	Terminals for connecting battery positive cable 1.
3	BAT2-	Terminals for connecting battery negative cable 2.
4	BAT2+	Terminals for connecting battery positive cable 2.
5	GEN	Terminals for connecting to a generator.
6	LOAD	Terminals for connecting to on-grid loads or back-up loads.
7	GRID	Terminals for connecting to the grid.
8	Communication port block	Ports for communication connection. Communication port block includes the following ports: CT1+, CT1-, BAT_T+, BAT_T-, EX_SD+, GND_S, G, G_S, +12V_RSD, and GND_S
9	RJ45 communication port	Ports for communication connection. RJ45 communication port includes the following ports: MODBUS_RS485, BMS_CAN, PARALLEL-1, PARALLEL-2, DRM, and METER_RS485

Table 2.2. Description of electrical terminals

2.7. LCD indicators

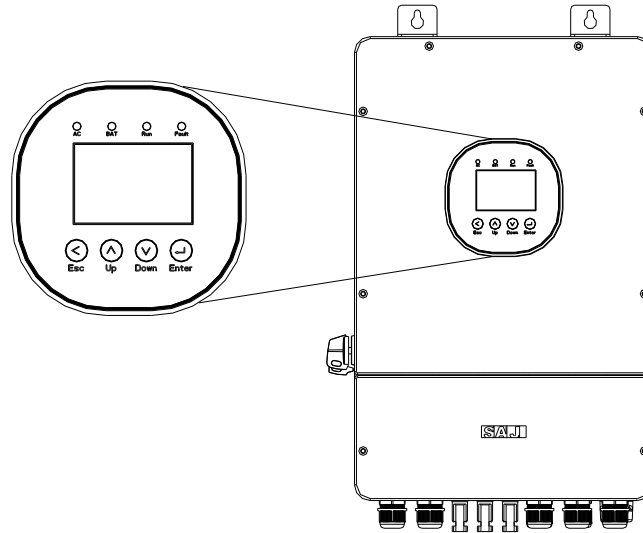

Figure 2.5 LCD indicators and buttons

LED indicator	Color	Status	Description
AC	Green	Solid on	The grid is connected and works properly.
BAT	Green	Solid on	The battery is working properly.
RUN	Green	Solid on	The inverter is working properly.
FAULT	Red	Solid on	The inverter is not working properly.

Table 2.3. Description of the LCD indicators

Button	Description
Esc	Exit the current operation.
Up	Scroll the screen up one line.
Down	Scroll the screen down one line.
Enter	Open the settings for the selected item.

Table 2.4. Description of the LCD buttons

3.

TRANSPORTATION AND STORAGE



3.1. Transportation

WARNING

- Do not drill holes into the product or its housing for any transportation-related purpose. Such modifications can damage the structural integrity and functionality of the device.
- Do not stack more than four cartons of inverters in a single pile.
- Ensure that transport vehicles are not overloaded and that weight is distributed evenly.
- Maintain stable driving conditions throughout transportation — avoid sudden acceleration, deceleration, or severe shaking.
- The weight of the inverter adheres to local regulations regarding manual handling requirements. Assign sufficient personnel for moving operations to avoid injury.
- Wear suitable protective gloves when manually handling equipment.
- When lifting the inverter, grip it firmly at the designated handles and support the base. Keep the unit level to avoid dropping.
- Use professional lifting and handling equipment operated by trained personnel with relevant skills and experience.

NOTICE

- The transportation service provider must be certified for handling and transporting inverters.
- All transportation equipment must be adequately prepared and inspected by authorized professional organizations to verify compliance and suitability.
- Inverters must be placed in their original packaging or specially designed transport packaging.
- Packaging materials should possess sufficient strength and cushioning properties to prevent damage from impact or compression during transportation.
- Securely fasten inverters within the packaging to prevent movement during transportation. For larger or heavier units, use additional restraints or fixing devices as necessary.
- Observe all safety symbols displayed on the packaging prior to and during transportation.

3.2. Storage

WARNING

- Do not unpack the inverter if it is not used immediately.
- Do not store the inverter in areas exposed to direct sunlight, rain, strong electric fields, or high humidity. Such conditions can cause overheating, electrical failure, or corrosion.
- Do not store inverters near chemically corrosive substances or in locations prone to pests or rodents. These can cause irreversible damage to housing and internal components.
- Do not stack more than four cartons of inverters in a single pile. Improper stacking may result in personal injury or device damage.
- Do not place heavy objects on top of the inverters. Crushing may deform the housing or damage internal components.
- Do not tilt or invert the packaging. Maintain the upright orientation as indicated on the carton to prevent internal displacement or component stress.

NOTICE

- The storage temperature must remain between -30°C to $+65^{\circ}\text{C}$ (-22°F to $+149^{\circ}\text{F}$), with relative humidity between 5% and 95% (non-condensing).
- Store inverters in a clean, dry, and well-ventilated area to avoid moisture buildup and overheating.
- Retain the original packaging with desiccants when storing inverters. Repackage properly if necessary.
- Regularly inspect stored inverters every three months. Check for environmental damage, pest intrusion, or packaging degradation.
- Promptly replace any packaging materials that have been damaged by insects or rodents.
- If an inverter has been stored for two years or longer, it must undergo inspection and functional testing by qualified personnel before being commissioned.

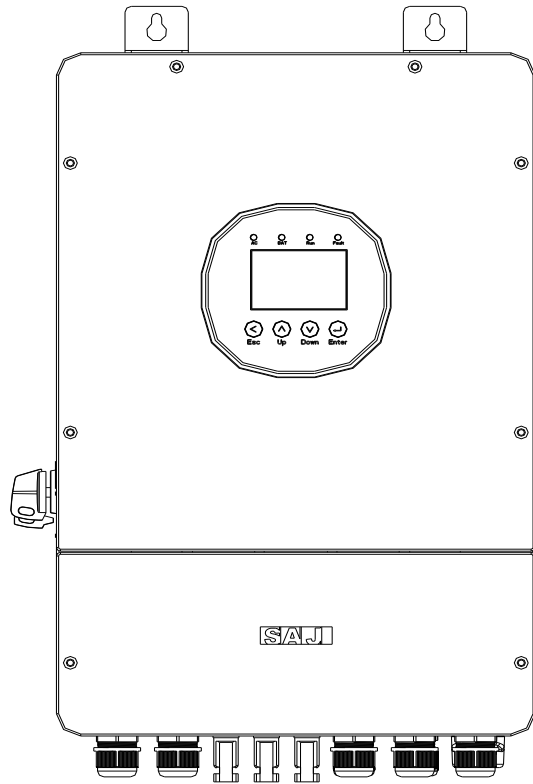

4.

INSTALLATION



4.1. Precautions

For safety, please read all safety instructions carefully before performing any work and comply with all applicable rules and regulations in the country or region where the product is installed.

DANGER

- Risk of fatal electric shock or fire.
- Keep the inverter away from flammable and explosive materials.

NOTICE

- Installation in unsuitable or non-compliant environments may reduce the inverter's service life.
- Avoid installing the inverter in direct, intense sunlight.
- Ensure the installation site is well-ventilated.

4.2. Installation diagram

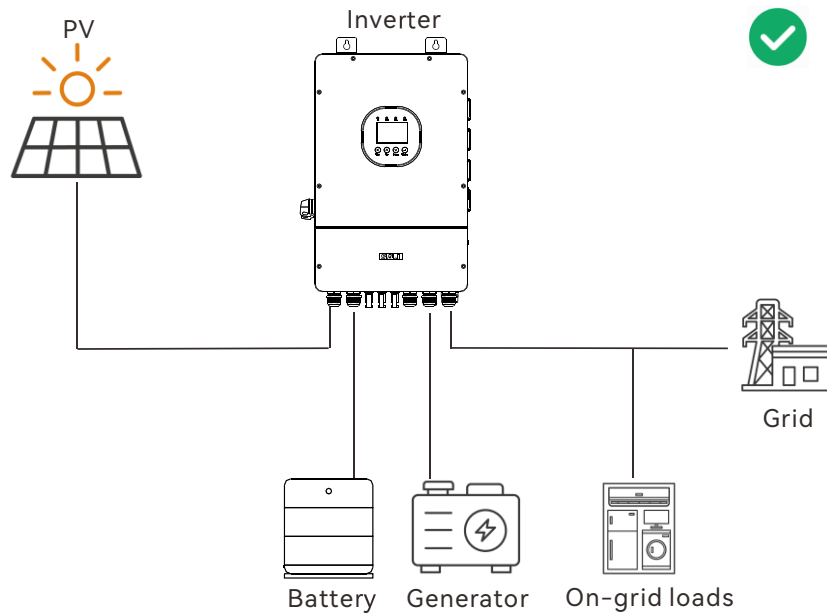
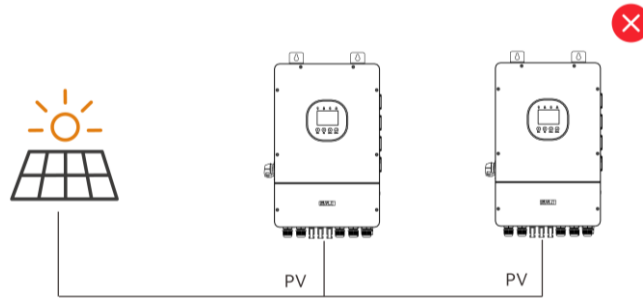

Figure 4.1. Applicable scenario

The following installation practices must be avoided. Any resulting damage will not be covered under warranty.

- Do not connect a single PV string to multiple inverters.



- Do not connect the back-up side to any AC generator.

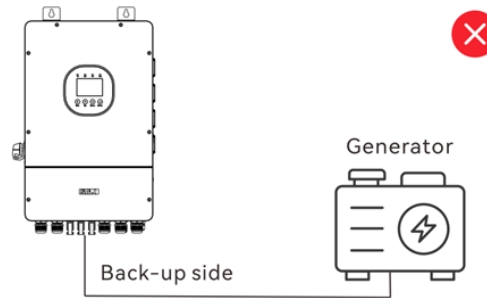

- Do not connect the back-up side to the grid.

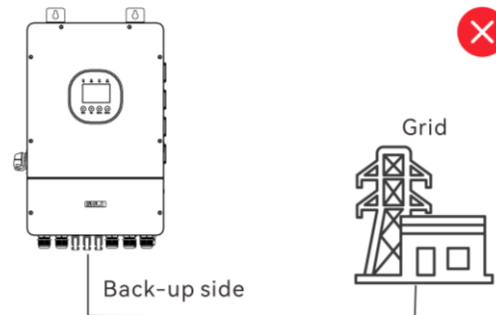

Figure 4.2. Non-applicable scenarios

4.3. Choose installation site

Read the following sections to carefully select a suitable installation site.

Note: safety regulations may differ across countries and regions. Always comply with all applicable local safety requirements.

4.3.1. Installation environment requirements

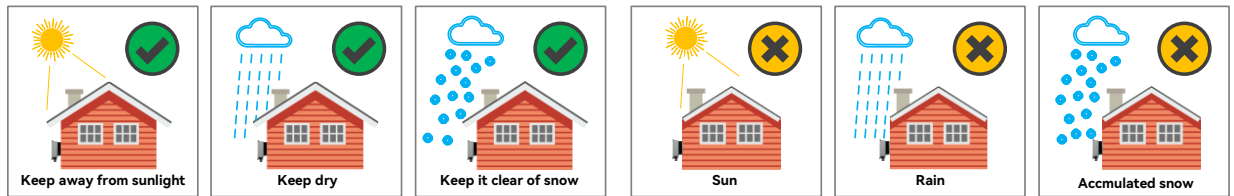

Figure 4.3. Installation location

- Do not expose the device to direct solar irradiation as this could cause power derating due to overheating.
- The installation environment must be free of inflammable or explosive materials.
- The device must be installed in a place away from heat sources.
- Do not install the device at a place where the temperature changes extremely.
- Keep the device away from children.
- Do not install the device in the bedroom, toilet, or bathroom.
- When installing the device at the garage, keep it away from the driveway.
- Keep the device from water sources such as taps, sewer pipes and sprinklers to prevent water seepage.
- It is recommended that the device be installed in an area where its status can be easily checked and maintained in case of failure or emergency.

4.3.2. Installation position requirements

- The device employs natural convection cooling, and it can be installed indoors or outdoors.
 - Indoor requirement
The battery connected to the device cannot be installed in the habitable rooms.
 - Outdoor requirement
Elevate the unit appropriately from the ground to avoid immersion in water.
The exact height should be determined based on the conditions of the installation site.
- Install the device vertically. The maximum allowable backward-tilted angle is 15 degrees.
- Do not install it forward-tilted, horizontally or upside down.

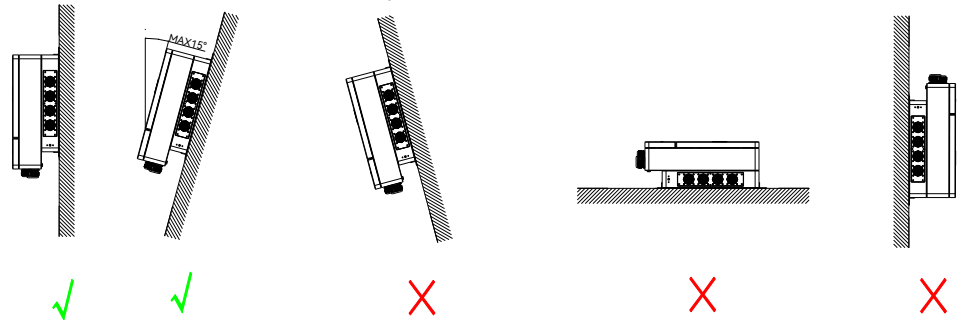

Figure 4.4. Installation position

- Select a solid and flat wall capable of supporting the total weight of the inverter and all associated accessories to ensure secure mounting.
- Maintain sufficient clearance around the inverter to allow for adequate airflow. This is especially important when installing multiple inverters in the same location.

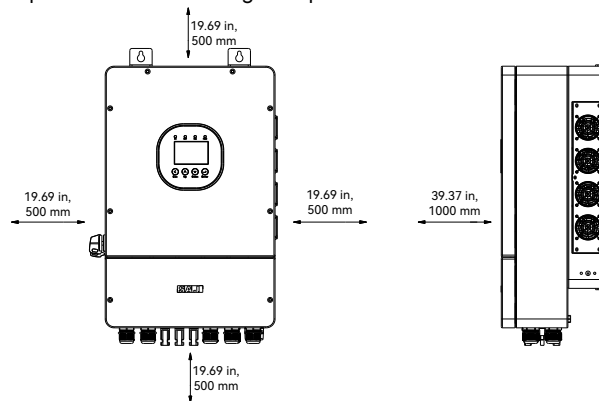

Figure 4.5. Installation clearance

4.4. Prepare installation tools

The installation tools below are for your reference. Tools include but are not limited to the following recommended ones. You may use other auxiliary tools based on site requirements.

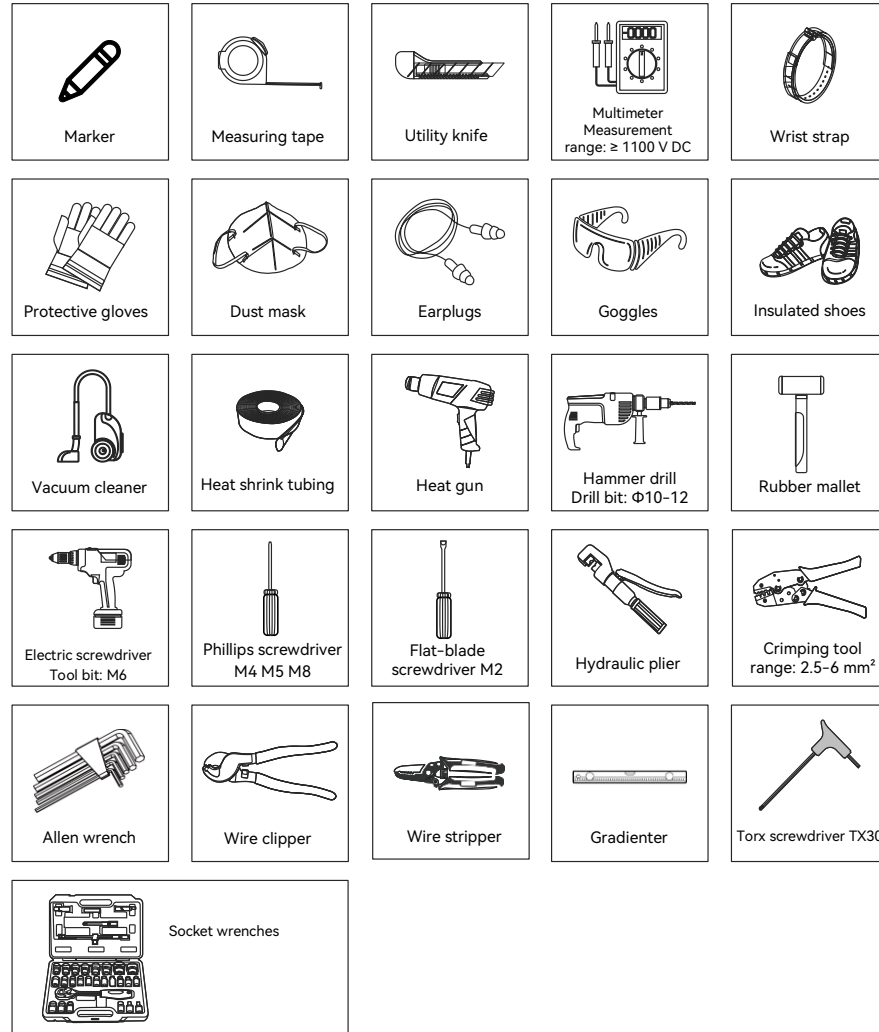

Figure 4.6. Suggested installation tools

4.5. Unpacking

4.5.1. Check the outer packing

Although all SAJ products undergo rigorous testing and inspection prior to shipment, damage may occasionally occur during transportation. Upon receipt, please perform the following checks:

- Check the outer packaging for any damage, such as holes and cracks.
- Check equipment model matches your order.

If any serious damage is found or the model is not what you requested, do not unpack the product.

Please contact your dealer immediately.

4.5.2. Check the package contents

1. Verify that the shipment contains everything that you expected to receive. Contact after-sales if there are missing or damaged components.
2. Place the connectors separately after unpacking to avoid confusion for cable connection.

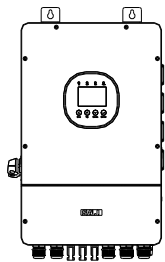

H2 inverter

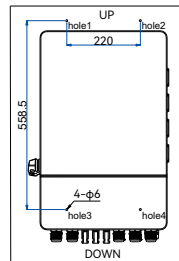

Hole positioning paper

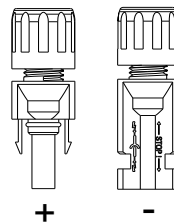

PV positive and negative connectors x4

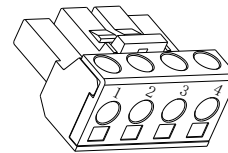

Communication Terminal



Cable lug x5

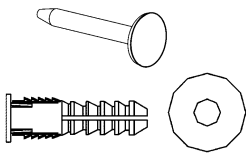

M6*50 screw suite x4

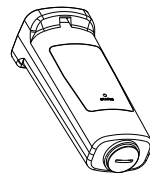

Communication module



Current transformer



Communication cable



Documents

4.6. Install the inverter

Before you start

Make sure that the wall is solid and flat enough to bear the weight of the inverter and accessories.

Procedure

Step 1. Stick the hole positioning paper onto the wall. Drill four holes according to the instructions of four holes (hole1, hole2, hole3, and hole4). Then, remove the paper.

Note: Reserve enough distance at the bottom for cable connection.

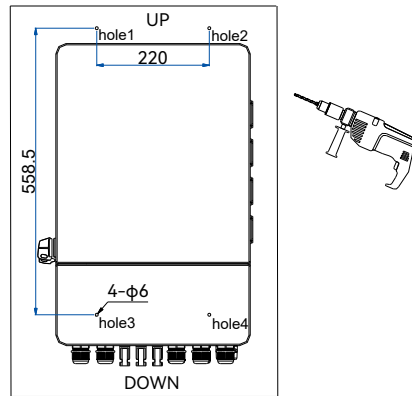

Figure 4.7. Drill four holes on the wall

Step 2. Use a rubber mallet to insert four expansion tubes into the holes.

Insert four M6*50 expansion bolts into the drilled holes.

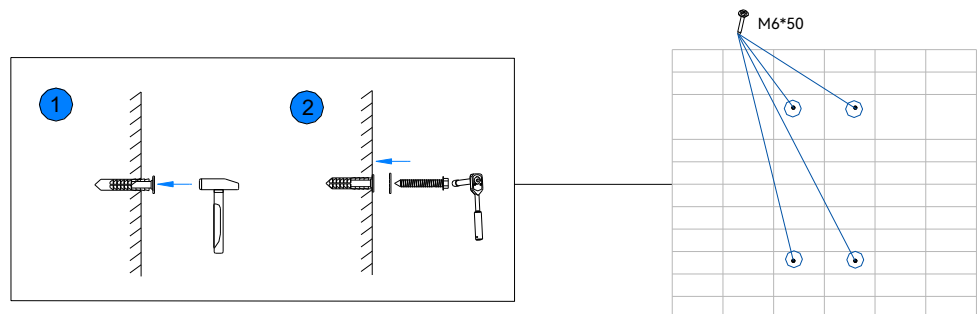
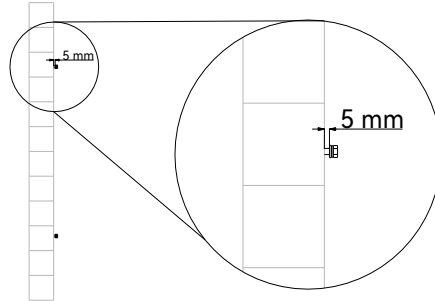

Figure 4.8. Install the mounting bracket onto the wall

Note: Reserve 5 mm distance between the wall surface and the head of the screws.



Step 3. Mount the inverter onto the mounting bracket.

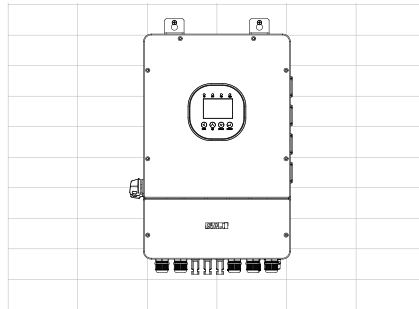

Figure 4.9. Mount the inverter onto the bracket

Step 4. Tighten the four expansion bolts.

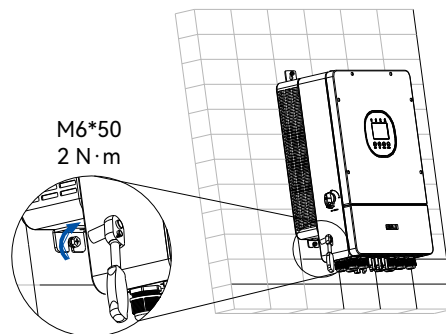



Figure 4.10. Secure the inverter

4.7. Install the battery

 **CAUTION**

- Do not connect the positive port (BAT+) to the negative port (BAT-) of the battery. This will short-circuit the battery and cause serious damage.

 **NOTICE**

- To comply with regulations, install a battery isolator $\geq 70A$ near the inverter. This is not required when using the SAJ B2 battery model (B2-5.0-LV1 or B2-5.0-LV2), as it incorporates a built-in DC isolator within its low-voltage box unit.

The H2 series inverter is compatible with the following SAJ batteries. For details on installing the battery, refer to the corresponding battery *User Manual*.

Brand	Compatible battery models
SAJ	B2-5.0-LV1, B2-5.0-LV2, B3-5.0-LV

5.

ELECTRICAL CONNECTION



5.1. Safety instructions

 **DANGER**

- Ensure that the equipment is powered off before performing any wiring operations.
- The direct connection between the inverter and high voltage power systems must be operated by qualified technicians in accordance with local and national power grid standards and regulations.
- Before connection, technicians must wear necessary protective equipment (PPE), including insulating gloves, insulating shoes, and a safety helmet.

 **NOTICE**

- Follow the connection procedure in this manual. Any improper operation during cable connection may cause device damage or personal injury.
- Electrical connection should be in conformity with proper stipulations, such as cross-sectional areas of conductors, fuses, and ground protection.

5.2. System connection and recommended cable list

 **WARNING**

- For safety operation and regulation compliance, circuit breakers should be installed between devices.
- Before connection, prepare appropriate circuit breakers and cables based on different connection scenarios. Check the recommended specification in the following tables. You may choose other sizes based on real needs.
- Do not connect multiple inverters to one AC breaker.
- If the inverter is installed far away from the grid connection point, select a larger cable size to ensure that the voltage drops from the grid connection point to the inverter is within 2% of the grid voltage.

- Basic system connection

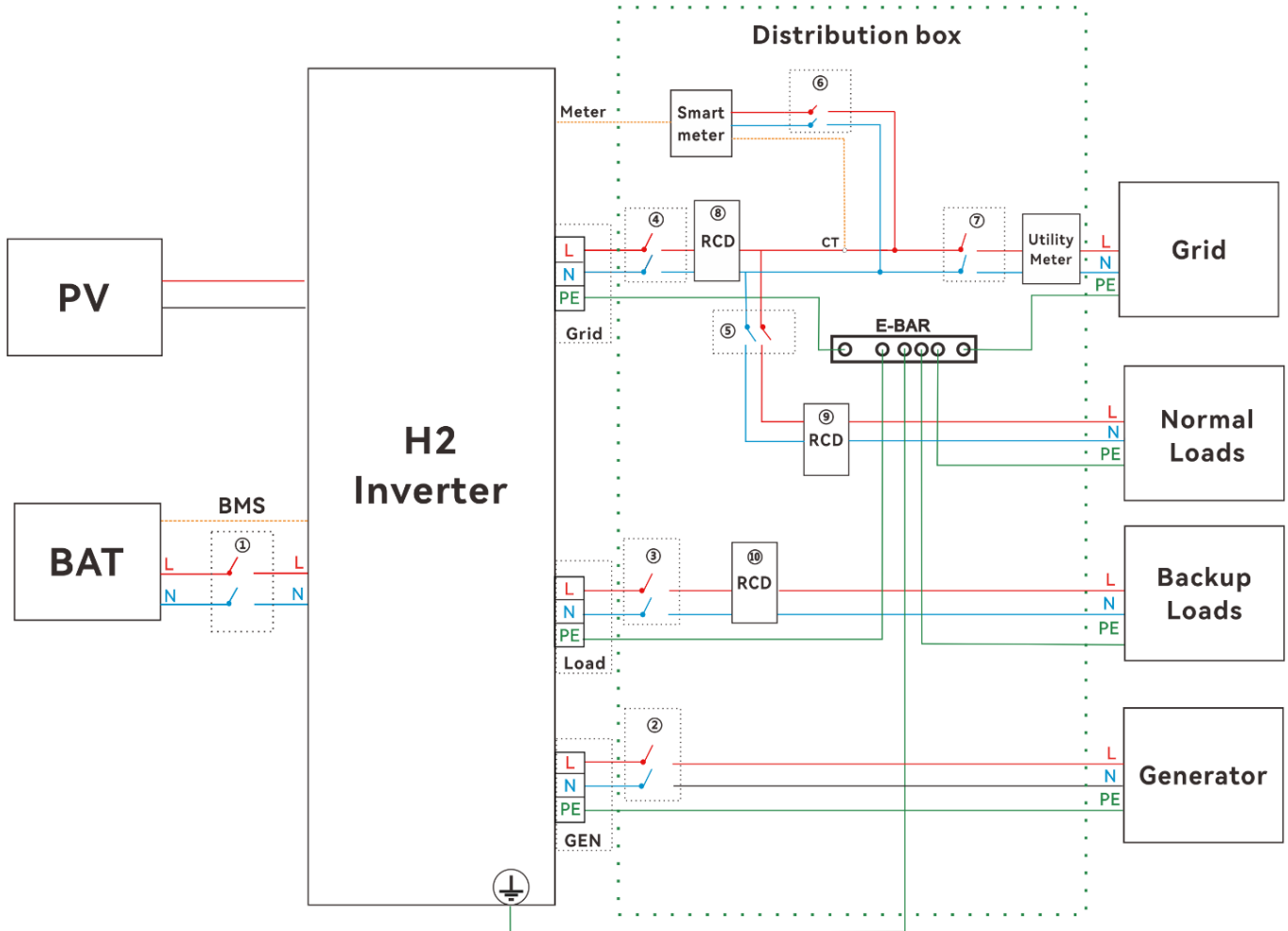

Figure 5.1. Basic system connection diagram

Model	① DC breaker for battery	② AC breaker for generator	③ AC breaker for backup loads	④ AC breaker for grid	⑤⑥ AC breaker for normal loads/smart meter	⑦ AC breaker for utility meter	⑧ RCD for grid	⑨⑩ RCD for normal and backup loads
H2-5K-LS2	125 A/60 V	32 A/230 V	32 A/230 V	32 A/230 V	Depends on loads and meter	Main breaker	300 mA RCD	30 mA RCD
H2-6K-LS2	150 A/60 V	40 A/230 V	40 A/230 V	40 A/230 V				
H2-7.6K-LS2	250A/60 V	50 A/230 V	50 A/230 V	50 A/230 V				
H2-8K-LS2	250A/60 V	50 A/230 V	50 A/230 V	50 A/230 V				
H2-10K-LS2	300A/60 V	63 A/230 V	63 A/230 V	63 A/230 V				
H2-12K-LS2	300 A/60 V	63 A/230 V	63 A/230 V	63 A/230 V				

Cable (90°C, Copper)	Recommended cross-sectional area (mm ²)						Stripping Length (mm)
	H2-5K-LS2	H2-6K-LS2	H2-7.6K-LS2	H2-8K-LS2	H2-10K-LS2	H2-12K-LS2	
Ground	6	6	6	10	10	10	15
PV	4	4	4	4	4	4	10
Battery	25	50	2*35	2*35	2*50	2*50	15
GEN	4	6	6	10	10	10	12
LOAD	4	6	6	10	10	10	12
GRID	4	6	6	10	10	10	12

- Whole home backup system connection

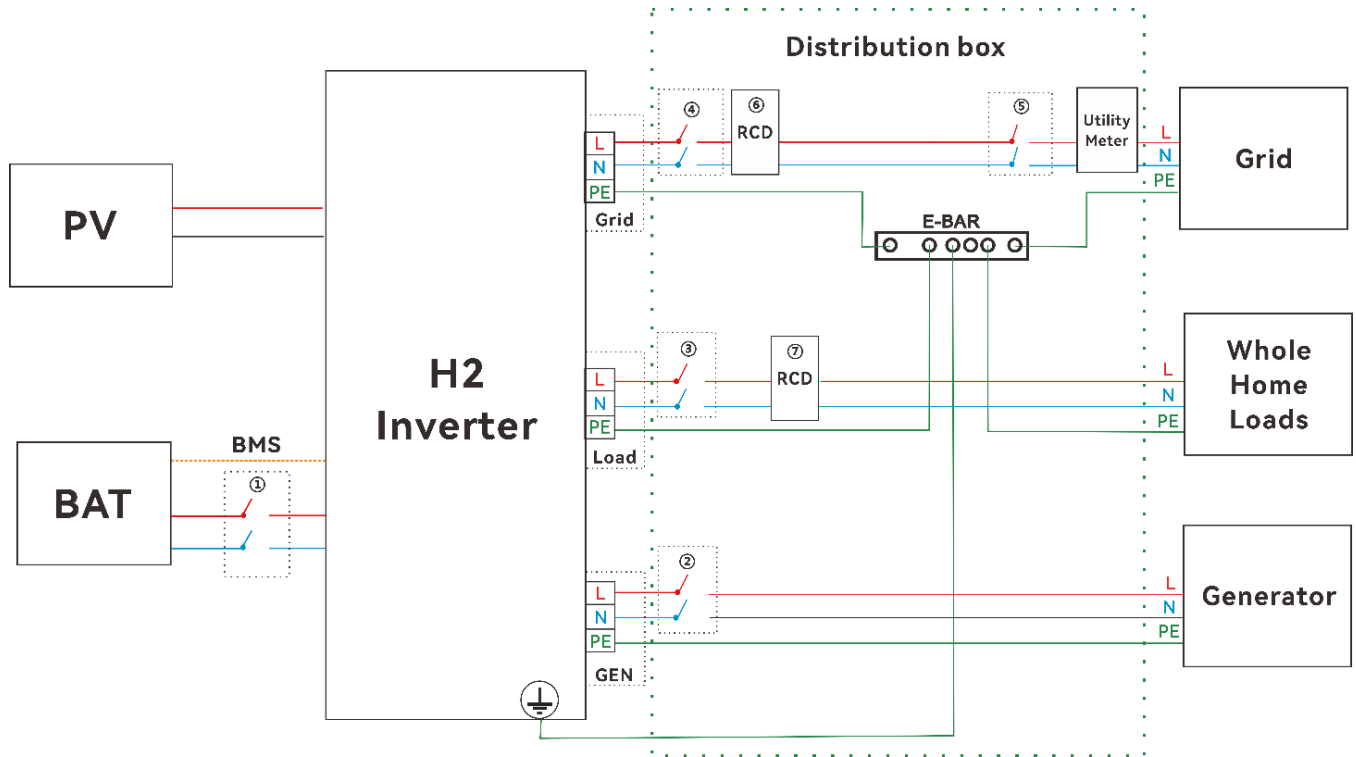
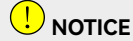

Figure 5.2. Whole home backup system connection diagram

Model	① DC breaker for battery	② AC breaker for generator	③ AC breaker for whole home loads	④ AC breaker for grid	⑤ AC breaker for utility meter	⑥ RCD for grid	⑦ RCD for whole home loads
H2-5K-LS2	125 A/60 V	32 A/230 V	63 A/230 V	63 A/230 V	Main breaker	300 mA RCD	30 mA RCD
H2-6K-LS2	150 A/60 V	40 A/230 V	63 A/230 V	63 A/230 V			
H2-7.6K-LS2	250A/60 V	50 A/230 V	63 A/230 V	63 A/230 V			
H2-8K-LS2	250A/60 V	50 A/230 V	63 A/230 V	63 A/230 V			
H2-10K-LS2	300A/60 V	63 A/230 V	63 A/230 V	63 A/230 V			
H2-12K-LS2	300 A/60 V	63 A/230 V	63 A/230 V	63 A/230 V			

Cable (Bypass) (90°C, Copper)	Recommended cross-sectional area (mm ²)						Stripping Length (mm)
	H2-5K-LS2	H2-6K-LS2	H2-7.6K-LS2	H2-8K-LS2	H2-10K-LS2	H2-12K-LS2	
Ground	6	6	6	10	10	10	15
PV	4	4	4	4	4	4	10
Battery	25	50	2*35	2*35	2*50	2*50	15
GEN	4	6	6	10	10	10	12
LOAD	10	10	10	10	10	10	12
GRID	10	10	10	10	10	10	12

5.3. Connect the grounding cable



NOTICE

The inverter cannot be used with functionally earthed PV Arrays.

About this task

- The grounding cable must be connected before other electrical connections.
- The cable needs to be prepared by the user.
- Choose appropriate cable according to the recommended cable list below or in **Section 5.2**. You may use other sizes based on real needs.

Cable (90°C, Copper)	Recommended cross-sectional area (mm ²)		Stripping Length	Recommended torque
	H2-(5K-7.6K)-LS2	H2-(8K-12K)-LS2		
Ground	6	10	15 mm / 0.59 inch	2 N·m / 17.70 LB-IN

Procedure

Step 1. Assemble the cable and OT/DT terminal.

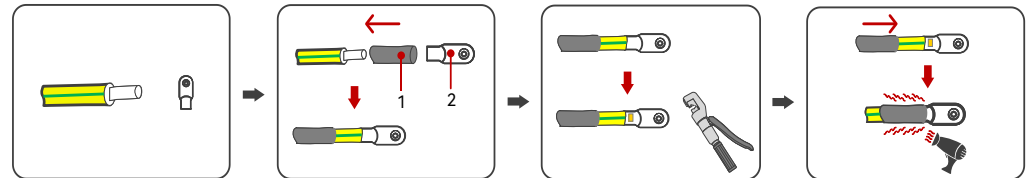

1-Heat shrink tube 2-OT/DT terminal

Figure 5.1. Prepare the grounding cable

Step 2. Remove the screw on the ground terminal and secure the cable.

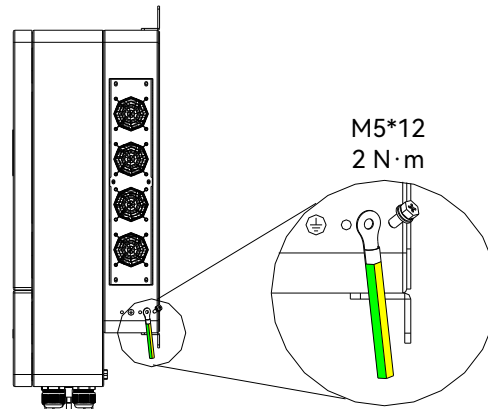

Figure 5.2. Connect the grounding cable

5.4. Open the junction box of the inverter

Procedure

Step 1. Use a screwdriver to loosen the two screws on the cover to remove the cover.

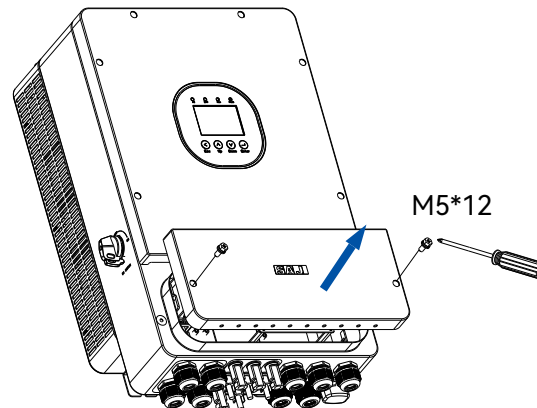

Figure 5.3. Open the junction box

5.5. Connect the battery to the inverter

WARNING

- A DC breaker must be installed between the inverter and the battery. Choose appropriate DC breaker according to the recommended cable list in **Section 5.2**. You may use other sizes based on real needs.
- Ensure that the DC breaker is in the OFF position.
- Before connection, use a multimeter to verify that the battery voltage measures 0 Vdc.
- Do not turn on the battery switch until all cables are properly connected.

About this task

The H2 series inverter is compatible with the following SAJ batteries. For details, refer to the corresponding battery *User Manual*.

Brand	Compatible battery models
SAJ	B2-5.0-LV1, B2-5.0-LV2, B3-5.0-LV

Note:

- For battery details, please refer to the user manual of the corresponding battery model.
- The H2 series inverter is only compatible with the batteries listed above. Using any other untested battery might cause damage to the inverter and thus void the inverter warranty.
- Some utility companies or electrical regulations may require a battery isolator to be installed near the inverter. Choose a $\geq 70A$ battery isolator for regulation compliance.

Procedure

Step 1. Strip off the insulation on the positive and negative battery cable ends.

Note: Use double-insulated cables for safety.

Cable (90°C, Copper)	Recommended cross-sectional area		Stripping length	Recommended torque
BAT+ and BAT-	H2-5K-LS2	25 mm ²	15 mm / 0.59 inch	4.5 N·m / 39.83 LB-IN
	H2-6K-LS2	50 mm ²		
	H2-7.6K-LS2	2*35 mm ²		
	H2-8K-LS2	2*35 mm ²		
	H2-10K-LS2	2*50 mm ²		
	H2-12K-LS2	2*50 mm ²		

If needed, crimp an insulation terminal on the cable end shown as follows:

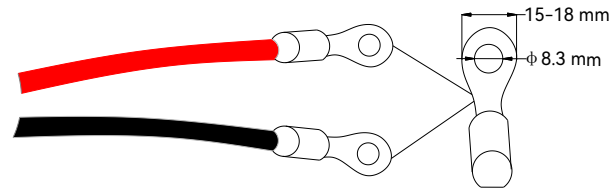

Figure 5.4. Crimp terminals on the cable ends

Step 2. Insert the cables through the cable gland **BAT 1-/1+/2-/2+** and connect the cables to the battery terminals **BAT1-/BAT1+** and **BAT2-/BAT2+** in the junction box.

Note: Each battery string supports a maximum input current of 160A.

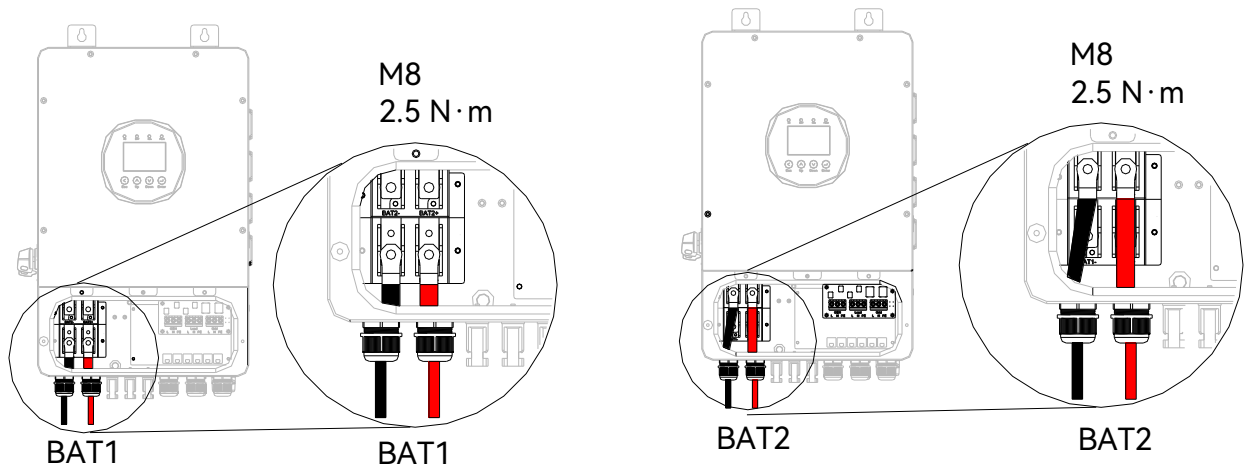

Figure 5.5. Connect the battery cables

5.6. Assemble the communication connection

5.6.1. Install the communication module

About this task

An RS232 USB communication port is provided at the bottom of the junction box. This port is used to connect communication modules, such as a Wi-Fi module or an AIO3 module.

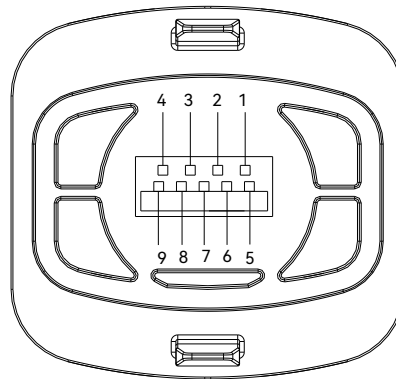

Pin	Description
1	+5V: Power supply
2	232TX: Transmit data
3	232RX: Receive data
4	GND
5	GND
6	NULL
7	NULL
8	NULL
9	+5V: Power supply

Table 5.1. Pin definitions

Procedure

Remove the cover on the WIFI port. Insert the communication module to the WIFI port.

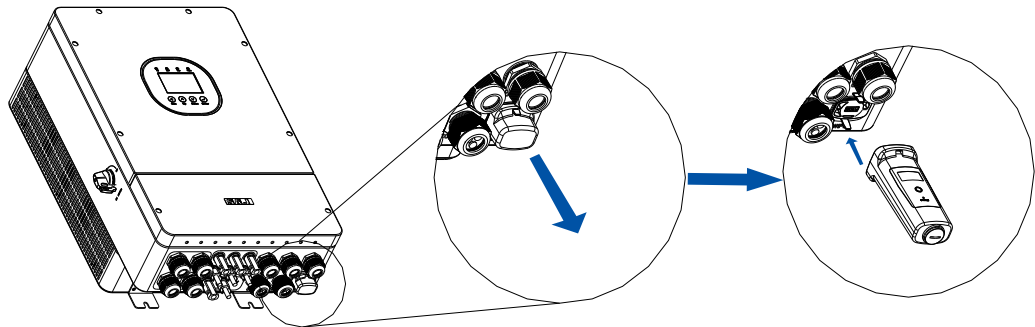

Figure 5.6. Installing the communication module

5.6.2. Connect the battery temperature sensor (for lead-acid batteries)

About this task

When lead-acid batteries are used, you need to connect the battery temperature sensor from the battery to the inverter.

Procedure

- Step 1. Connect the battery temperature sensor to the battery.
- Step 2. Insert the cable of the battery temperature sensor through **COM1** cable gland.
- Step 3. Insert the two cables into terminals **3** and **4** on the communication terminal block and use small flat-head screwdriver to tighten the screws.

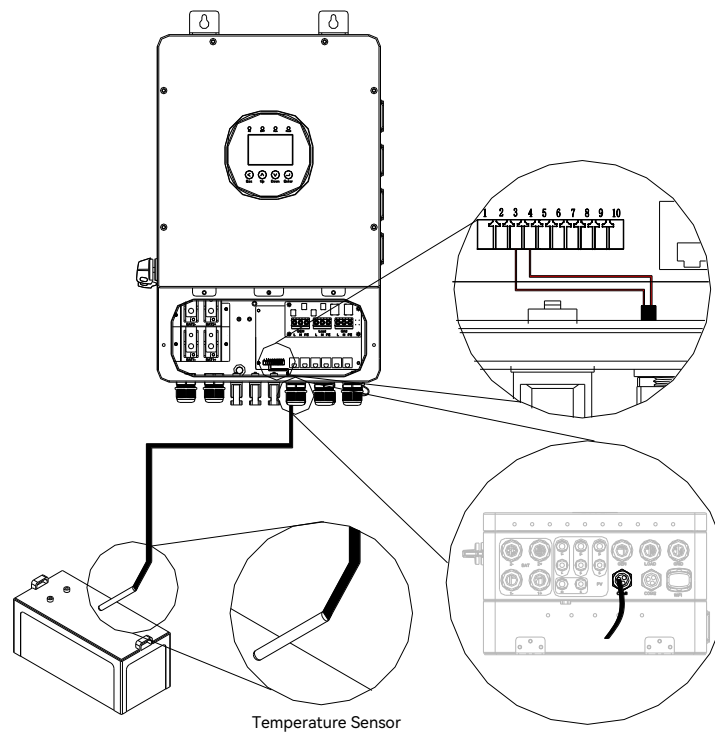

Figure 5.7. Connecting the battery temperature sensor

5.6.3. Connect the RJ45 ports

1. Per your needs, prepare communication cables according to the pin definition of RJ45 ports.

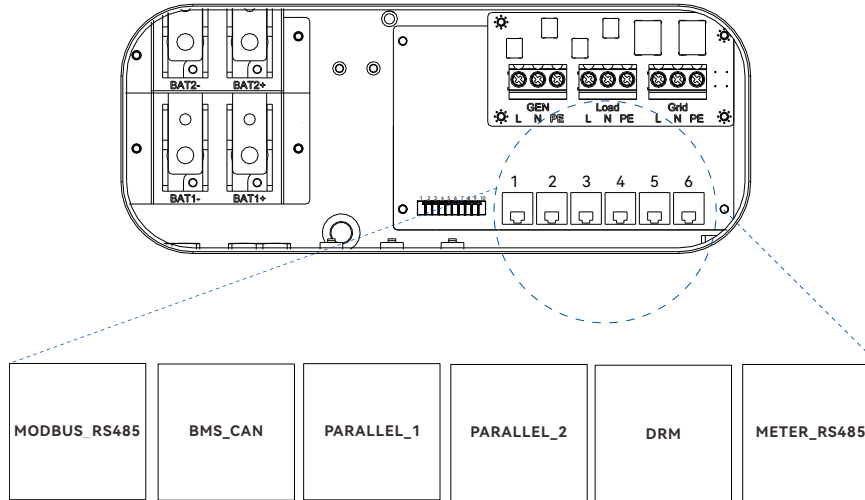
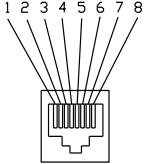
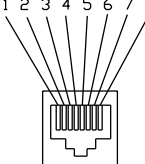

Figure 5.8. RJ45 ports

No.	Port	Description
1	MODBUS_RS485	Reserved RS485 communication port for future use.
2	BMS_CAN	The inverter can communicate with the battery control unit through BMS_CAN terminal. For detailed connection methods, refer to Section 5.6.3.3 “BMS_CAN connection” of the User Manual.
3	PARALLEL_1	Parallel connection is performed through the PARALLEL_1 and PARALLEL_2 terminals. For detailed parallel connection methods, refer to Section 5.6.3.2 “Parallel Connection” of the User Manual.
4	PARALLEL_2	
5	DRM	According to AS/NZS 4777.2, inverters must support the Demand Response Mode (DRM). With the use of external Demand Response Enabling Device (DRED), the inverter can adjust active and reactive power output to maintain grid stability and efficiency. For detailed connection methods, refer to Section 5.6.3.1 “DRM connection” of the User Manual.
6	METER_RS485	The inverter can communicate with the meter through METER_RS485 terminal. For detailed connection methods, refer to Section 5.6.3.4 “METER485 connection” of the User Manual.

Table 5.2. Description of RJ45 ports

MODBUS_RS485 (Reserved for future use)		
1	RS485_B	
2	RS485_A	
3	GND_S	
4	NC	
5	NC	
6	GND_S	
7	RS485_B	
8	RS485_A	

BMS_CAN		
1	NC	
2	NC	
3	NC	
4	CANH	
5	CANL	
6	NC	
7	NC	
8	NC	

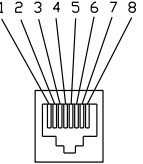
Parellel_1		
1	CANH	
2	CANL	
3	BKUP TO GRID_BUS+	
4	CAN1_H	
5	CAN1_L	
6	CARRY_BUS+	
7	GRID TO BKUP_BUS+	
8	GND_S	

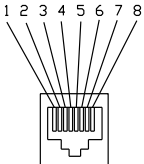
Parellel_2		
1	CANH	
2	CANL	
3	BKUP TO GRID_BUS+	
4	CAN1_H	
5	CAN1_L	
6	CARRY_BUS+	
7	GRID TO BKUP_BUS+	
8	GND_S	

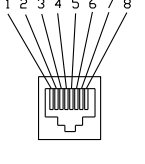
DRM		
1	DRM 1/5	
2	DRM 2/6	
3	DRM 3/7	
4	DRM 4/8	
5	RefGen	
6	Com/DRM 0	
7	V+	
8	V-	

METER_RS485		
1	RS485_B1	
2	RS485_A1	
3	GND_S	
4	RS485_B1	
5	RS485_A1	
6	GND_S	
7	RS485_B1	
8	RS485_A1	

Table 5.3. Pin definition of RJ45 ports

- Strip the insulation of the communication cables with a wire stripper and separate the corresponding signal wires according to the pin definition.

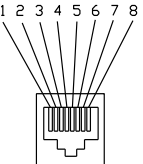
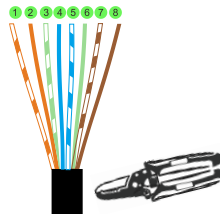

Figure 5.9. Stripping the communication cable

- Insert the cables through the cable gland **COM2** and connect the cables to the corresponding RJ45 ports.

5.6.3.1. DRM connection

In accordance with AS/NZS 4777.2, the inverter features a Demand Response Mode (DRM).

- **DRM pin description**

Pin	Description
DRM 1/5	DRM 1: Do not consume power. DRM 5: Do not generate power.
DRM 2/6	DRM 2: Do not consume more than 50% of rated power. DRM 6: Do not generate more than 50% of rated power.
DRM 3/7	DRM 3: Do not consume more than 75% of rated power and supply reactive power if capable. DRM 7: Do not generate more than 75% of rated power and absorb reactive power if capable.
DRM 4/8	DRM 4: Increase power consumption. DRM 8: Increase power generation.
RefGen	Accept analog voltage signals from the external control box to regulate the inverter's output power level.
Com/DRM 0	Com: Common reference for digital signals. DRM 0: Operate the disconnection device.
V+	For connecting to power supply, which provides operating power to the external control box.
V-	For connecting to power ground.

Table 5.4. DRM pin description

5.6.3.2. Parallel connection

The H2 series single-phase inverter supports parallel operation for up to 4 units in both on-grid and off-grid modes.

- **Communication connection for parallel operation**

Parallel connection is performed through the PARALLEL_1 and PARALLEL_2 ports.

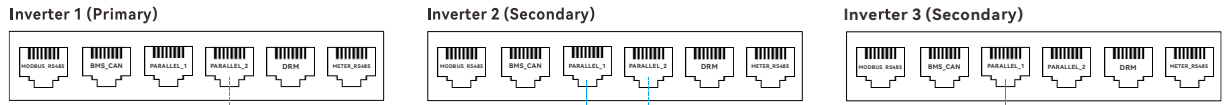

Figure 5.10. Communication connection for parallel operation

- **System connection for parallel operation**

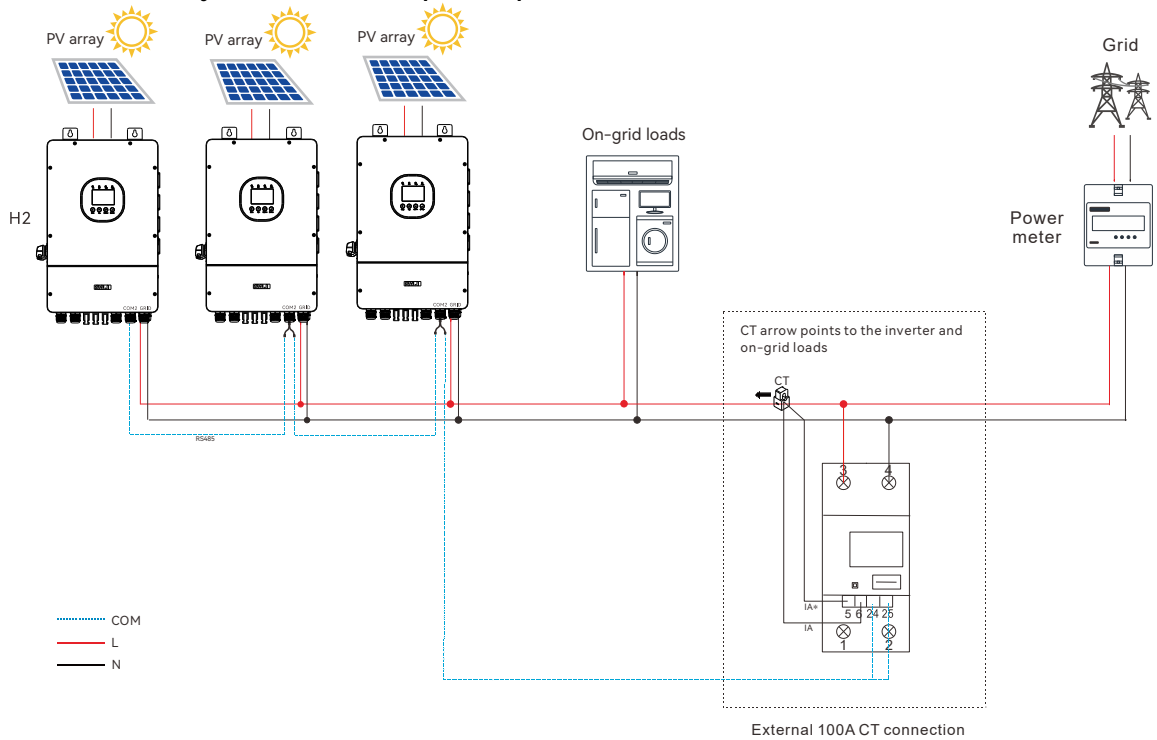

Figure 5.11. System connection for parallel operation

5.6.3.3. BMS connection

The inverter can communicate with the battery through the BMS terminal. The Li-ion battery connection method is shown below.

Note: For lead-acid battery connection method, refer to **Section 5.6.2** Connect the battery temperature sensor (for lead-acid batteries).

- **Li-ion battery connection**

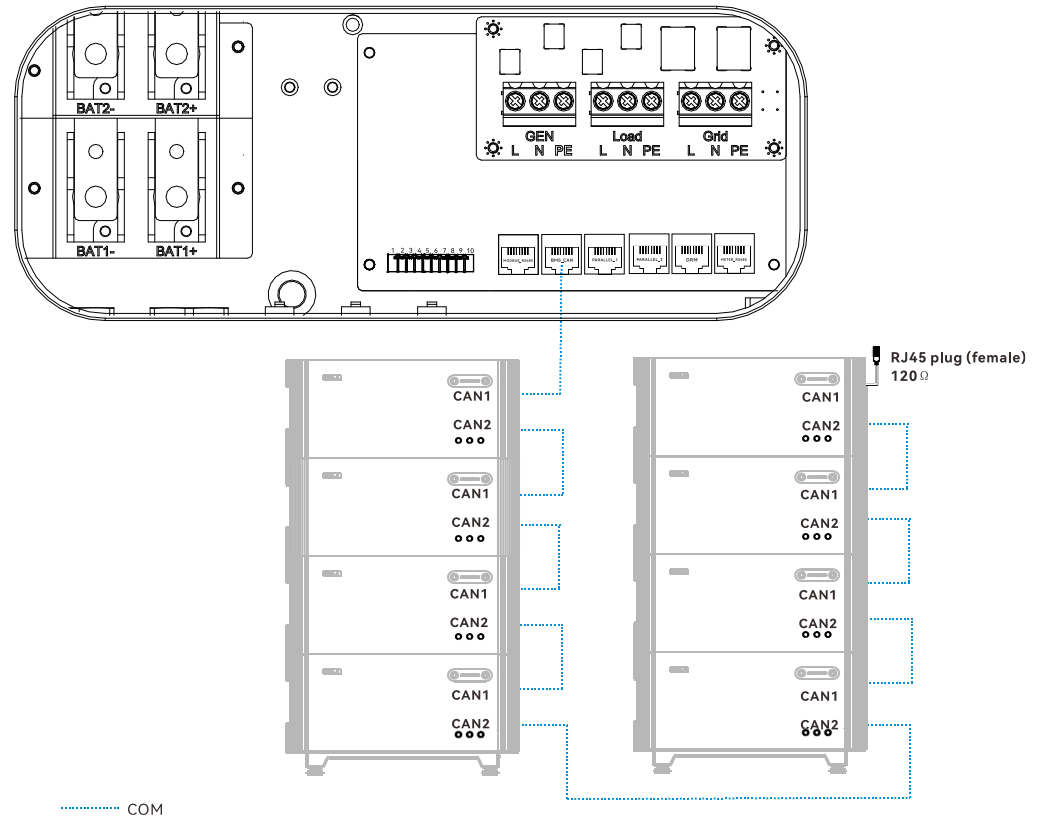

Figure 5.12. BMS connection

5.6.3.4. Smart meter connection



NOTICE

- Each inverter requires a dedicated smart meter.
- Each smart meter must be used with one CT. The CT should be installed at the same phase as the meter power cables.
- CT has a symbol of arrow indicating the correct installation orientation on the conductor. Verify this direction before installation.

The smart meter kit and CT are necessary for system installation and provide the operating condition of the inverter via RS485 communication. There are two connection schemes, one is external CT connection with meter, the other is internal CT connection without meter.

• External CT connection with meter

Step 1. Connect meter's terminals **3**, **4** to Grid **L**, **N** respectively.

Step 2. Clamp the CT to Grid **L**.

Step 3. Connect the CT cables **IA*** and **IA** to meter's CT terminals **5** and **6**, respectively.

Step 4. Connect the meter's terminals **24** and **25** to the inverter's **METER_RS485** port.

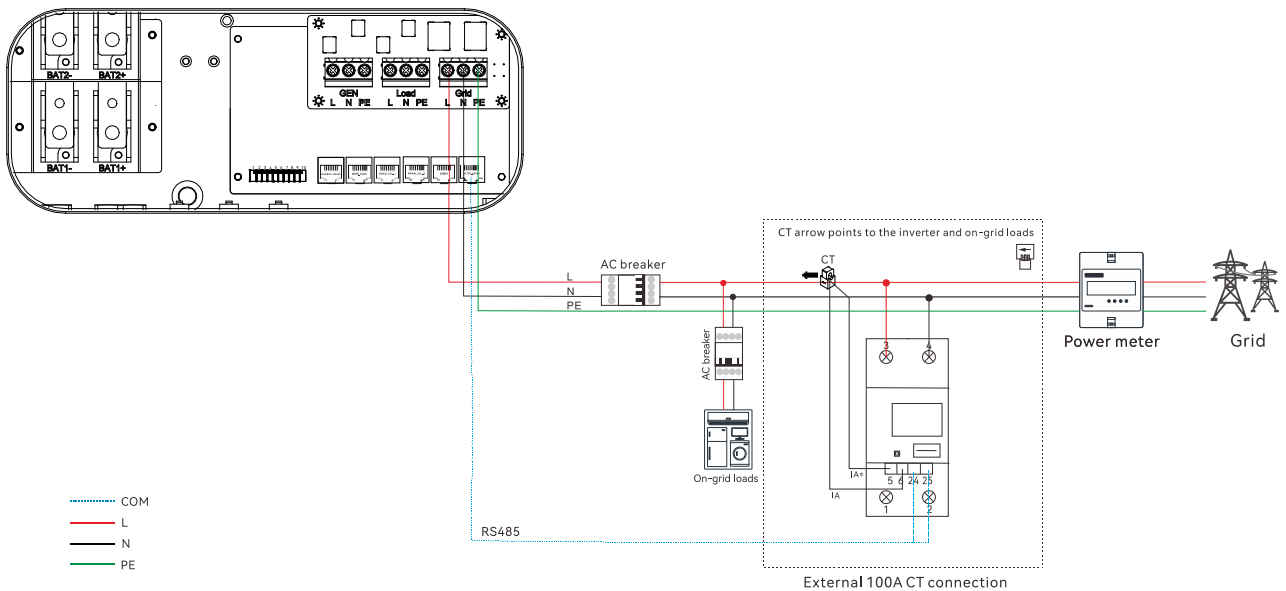

Figure 5.13. External CT connection with meter

- **External CT connection without meter**

Step 1. Clamp the CT to Grid L.

Step 2. Connect the CT cables (**I-Blue** and **I*-White**) to the inverter's communication terminals **1** and **2** (**CT1+** and **CT1-**).

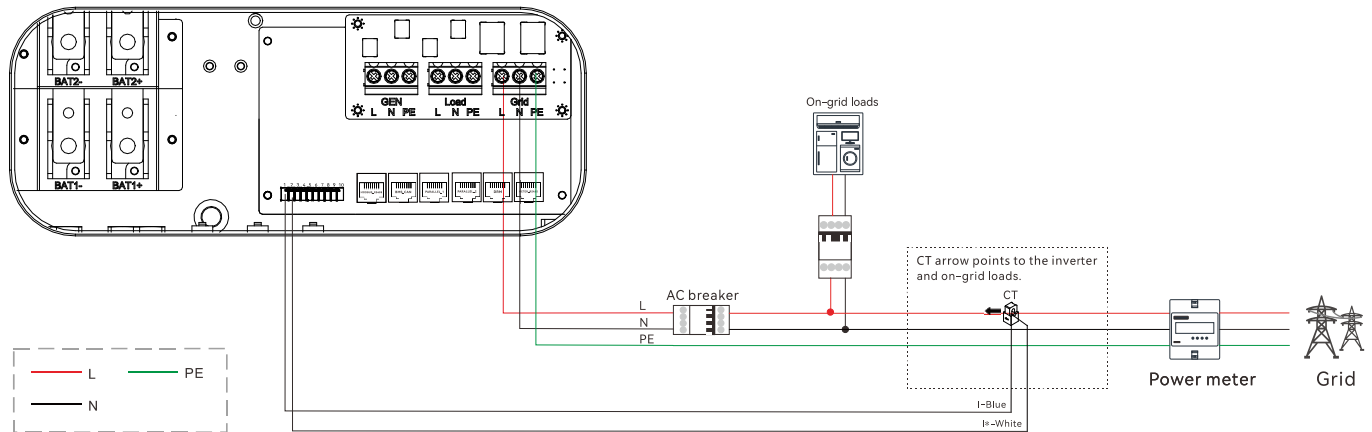

Figure 5.14. External CT connection without meter

5.6.4. Connect the communication terminal

1. Per your needs, prepare communication cables according to the description below.

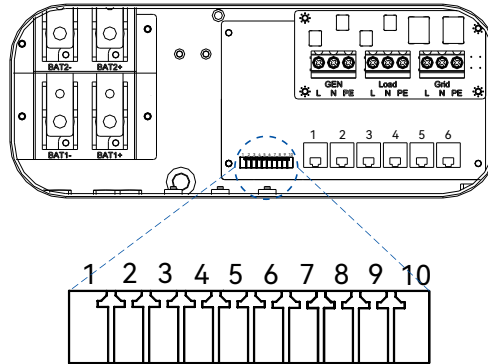

Figure 5.16. Communication ports

No.	Terminal	Description
1	CT1+ (blue)	For connecting the CT cable (blue cable).
2	CT1- (white)	For connecting the CT cable (white cable).
3	BAT_T+	For connecting the positive cable of the battery temperature sensor (only for lead-acid batteries).
4	BAT_T-	For connecting the negative cable of the battery temperature sensor (only for lead-acid batteries).
5	EX_SD+	For connecting to external emergency stop switch.
6	GND_S	For connecting to external emergency stop switch.
7	G	For connecting to external generator dry contact.
8	G_S	For connecting to external generator dry contact.
9	+12V_RSD	For connecting to 12V power supply.
10	GND_S	For connecting to 12V power ground.

Table 5.5. Description of communication terminals

2. Insert the cables through the cable glands **COM1** and connect the cables to the corresponding terminals using small flat-head screwdriver.

5.7. Assemble the AC-side electrical connection



WARNING

Risk of personal injury due to electric shock

- An independent AC breaker must be installed on the output side of the inverter to ensure safe disconnection from the grid.
- Before connection, ensure that the AC breakers are in the OFF position.
- Multiple inverters cannot share one circuit breaker.
- Do not connect the load between the inverter and the circuit breaker.
- Before connection, ensure that the AC-side equipment is powered off.
- Ensure the rated power of the load does not exceed the rated output power of the inverter.
- Before connecting, use a multimeter to verify that the AC voltage measures 0 Vdc.
- Improper wiring of AC conductors will result in risks of electrical failure or equipment damage. Ensure that all connections are made correctly in accordance with the instructions in this document and in accordance with local wiring codes and regulations before applying power to the unit.



NOTICE

- If the inverter is installed far away from the grid connection point, select a larger cable size to ensure that the voltage drops from the grid connection point to the inverter is within 2% of the grid voltage.

About this task

For safety and regulation compliance, AC breakers must be installed on the output side of the inverter. Choose appropriate AC breaker according to the recommended cable list in **Section 5.2**. You may use other sizes based on real needs.

Procedure

Step 1. Strip the insulation on the GEN/LOAD/GRID cable ends.

Note: Use double-insulated cables for safety.

- Basic electrical connection

Cable (90°C, Copper)	Recommended cross-sectional area (mm ²)				Stripping length	Recommended torque
	H2-5K-LS2	H2-6K-LS2	H2-7.6K-LS2	H2-(8K-12K)-LS2		
GEN	4	6	6	10	12 mm / 0.47 inch	1 N·m /8.85 LB-IN
LOAD	4	6	6	10		
GRID	4	6	6	10		

- Whole home backup connection

Cable (90°C, Copper)	Recommended cross-sectional area (mm ²)				Stripping length	Recommended torque
	H2-5K-LS2	H2-6K-LS2	H2-7.6K-LS2	H2-(8K-12K)-LS2		
GEN	4	6	6	10	12 mm / 0.47 inch	1 N·m /8.85 LB-IN
LOAD	10	10	10	10		
GRID	10	10	10	10		

Table 5.6. Recommended cable specifications for GEN, LOAD and GRID

5.8. Assemble the PV-side electrical connection

Step 1. Prepare the PV cables according to the following specification.

Cable	Recommended cross-sectional area
PV+ and PV-	4 mm ²

Table 5.7. Recommended cable specification for PV

Step 2. Loosen the lock screws on positive and negative connectors.

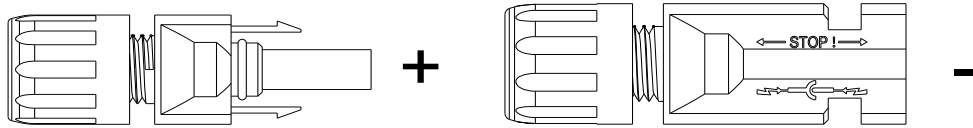

Figure 5.18. Loosening the lock screws on connectors

Step 3. Strip off the insulation of the positive and negative cables by 8–10 mm (0.31–0.39 inch).

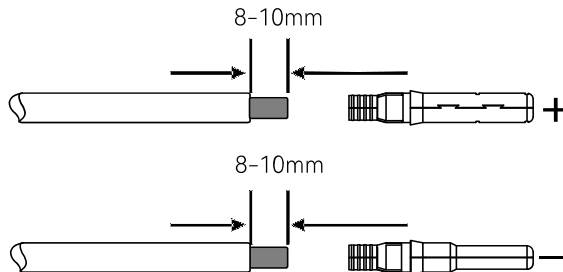

Figure 5.19. Stripping off the cable insulation

Step 4. insert the cable ends into the sleeves. Use a crimping plier to assemble the cable ends.

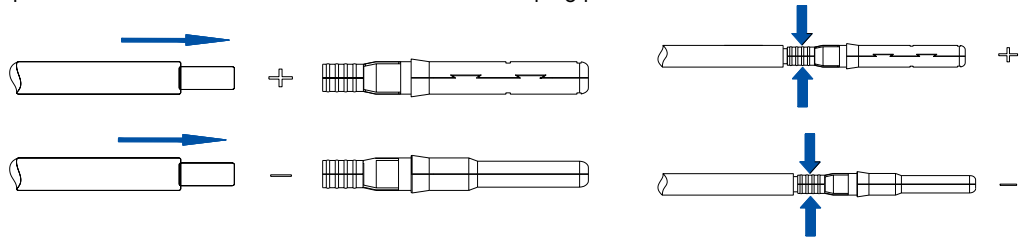

Figure 5.20. Assembling the cable ends

Step 5. Insert the assembled cable ends into the positive and negative PV connectors. Gently pull the cables backwards to ensure firm connection.

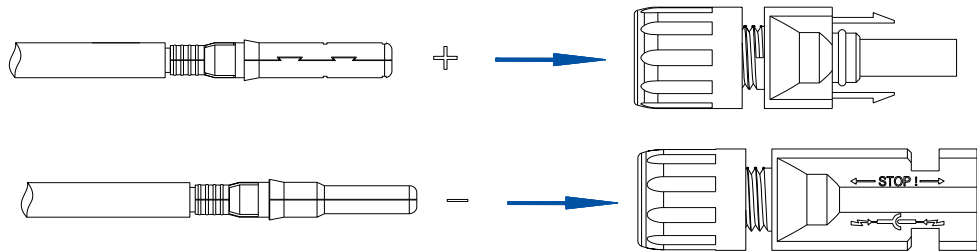

Figure 5.21. Inserting the assembled cables into connectors

Step 6. Tighten the lock screws on the positive and negative cable connectors.

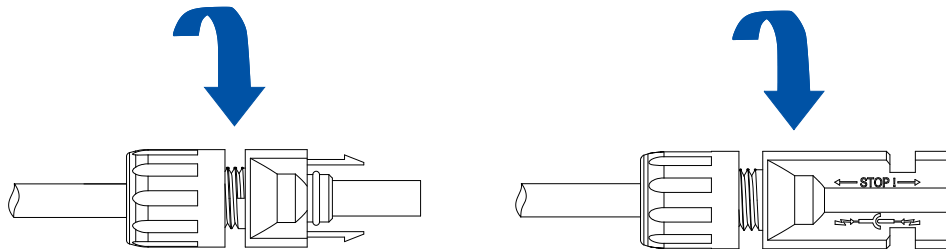

Figure 5.22. Tightening the lock screws on connectors

Step 7. Make sure that the DC switch is at the OFF position.

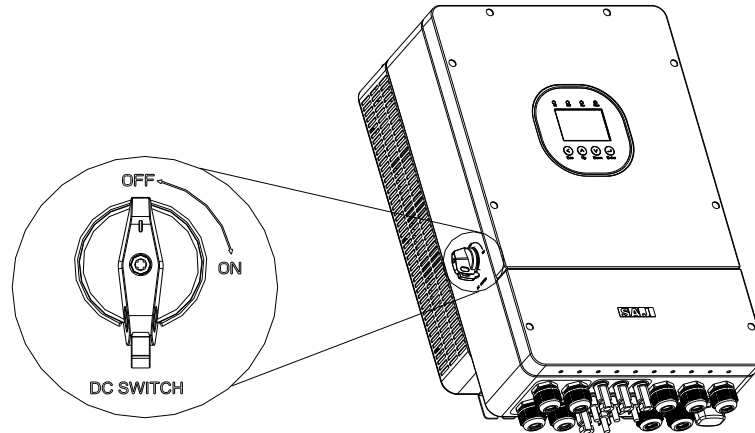

Figure 5.23. Turning OFF the DC switch

Step 8. Connect the positive and negative connectors into the positive and negative DC input terminals of the inverter. A “click” sound should be heard when the contact cable assembly is seated correctly.

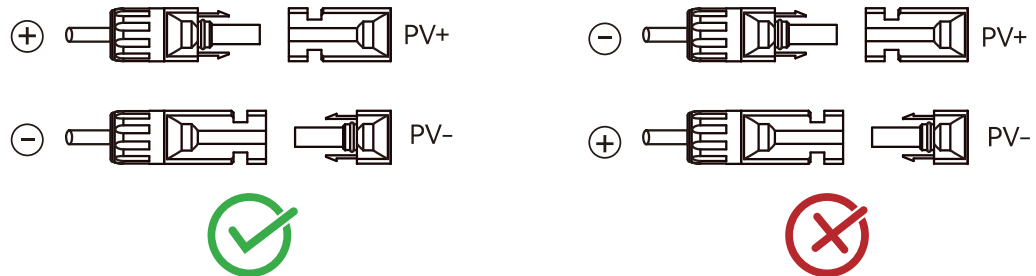

Figure 5.24. Connecting the connectors into terminals

5.9. Close the junction box of the inverter

Step 1. Install the cover back to the inverter and tighten the screws.

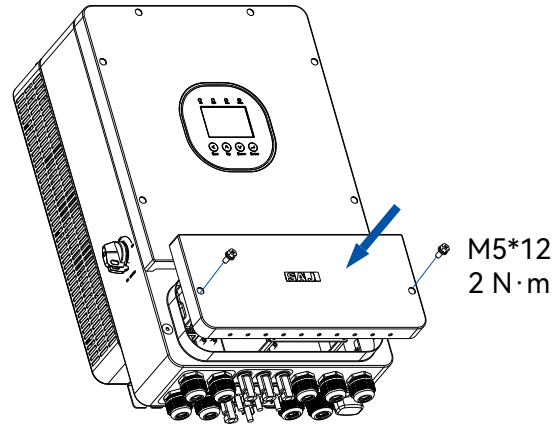
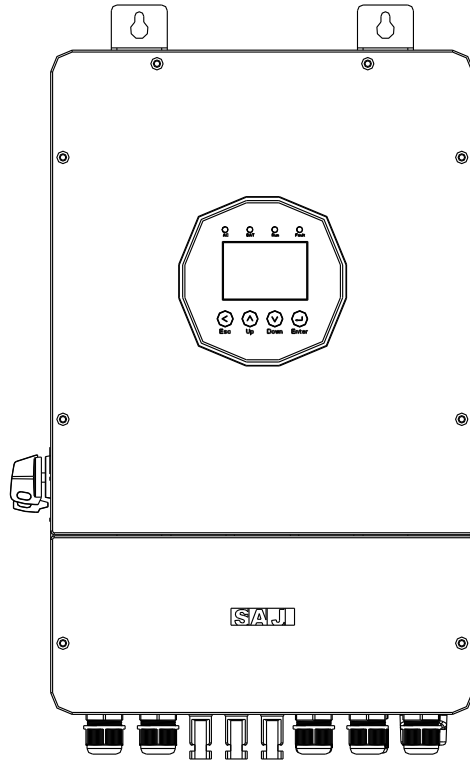

Figure 5.25. Closing the cover of the junction box



6.

**STARTUP AND
SHUTDOWN**



6.1. Startup

Step 1. Open the junction box. Turn on the following breakers by pushing their handles upwards:

- a. Load breaker (optional, only when loads are connected)
- b. Battery breaker

Step 2. Turn on the breaker on the grid side.

Step 3. Turn on the DC switch on the left side of the inverter to establish the connection to the PV array.

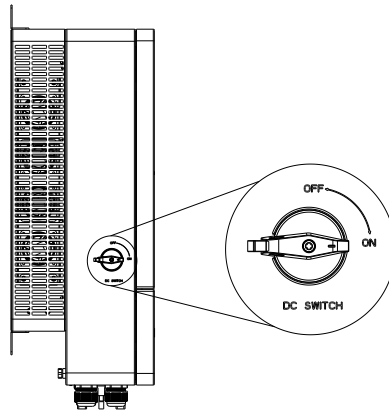

Figure 6.1. DC switch on the left side of the inverter

Step 4. Turn on the battery switch on the battery. For details, refer to the battery user manual.

Step 5. Check the LED indicator status on the inverter panel to verify that the inverter is operating properly. For details, refer to **Section 2.7 “LCD indicators”**.

6.2. Shutdown

Step 1. To disable the connection to PV array, turn off DC switch on the left side of the inverter.

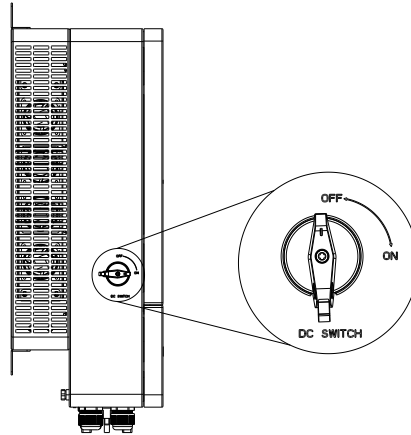

Step 2. To disable the connection to battery, turn off the battery switch on the battery.

Step 3. Turn off the battery breaker switch and load breaker switch.

Step 4. Turn off the breaker on the grid side.

6.3. Emergency shutdown

In an emergency, press the START button on the left side of the inverter to shut down the system.

Once pressed, the system will power off immediately.

6.4. Restart after emergency shutdown

After the emergency is subsided, press the START button to restart the system.

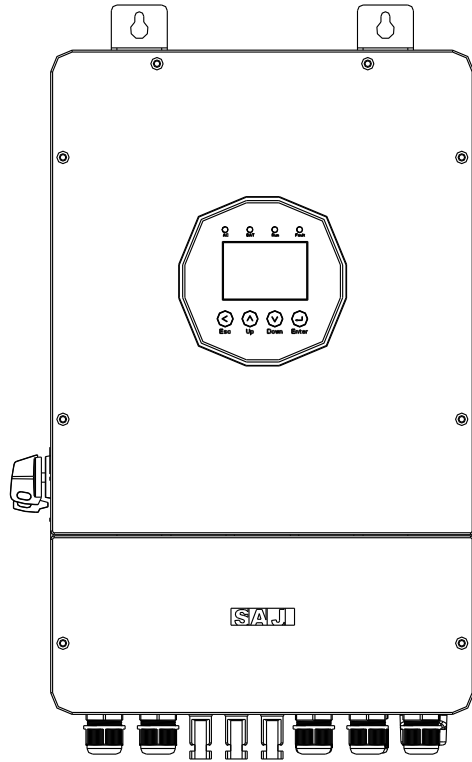

7.

COMMISSIONING ON THE APP



7.1. Download the App

The elekeeper App can be used for both nearby and remote monitoring. Depending on the communication module used, it supports Bluetooth/4G or Bluetooth/Wi-Fi to communicate with your energy storage system (ESS).

On your mobile phone, search for “elekeeper” in the App store and download the App.

7.2. Log in to the App

Note: The detailed operations on the App might vary, depending on the version you are using.

If you have an account, log in to the App directly:

- Tap the three-dot icon **•••** on the top right corner. Choose the language and network node based on your needs.
- Log in to the App by using the account and the password.

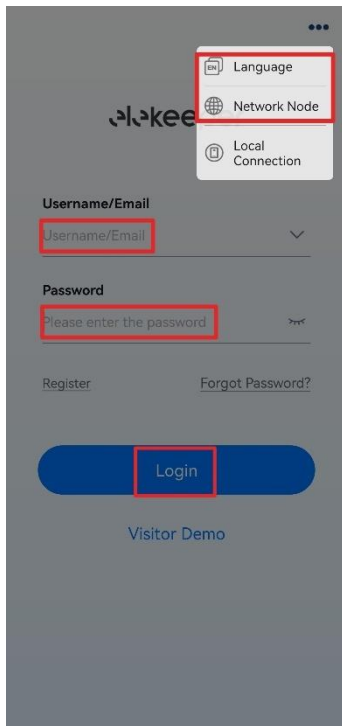

To apply for a new account, perform as follows:

- Tap the three-dot icon **•••** on the top right corner. Choose the language and network node based on your needs.
- Tap **Register**. Choose whether you are an owner or an installer or distributor.
- Follow the instructions on the screen to complete the registration.
- Log in to the App by using the new account and the password.

Example (for installer):

The first screenshot shows the login screen with a three-dot menu icon in the top right corner. A red box highlights the menu options: Language, Network Node, Local Connection, and a Register button. The Register button is also highlighted with a red box. Below the Register button is a Login button and a Visitor Demo link.

The second screenshot shows the 'Select Role' screen. It has two options: 'I'm an owner' (Real-time Monitoring and Analysis of Power Generation, Power Storage, and Power Consumption) and 'I'm an installer/distributor' (Create Plant, Monitoring & Analysis, O&M Tools). The 'I'm an installer/distributor' option is selected.

The third screenshot shows the 'Register' screen. It has a note: 'Note: If your company has registered an account in the system, you do not need to register. Please ask your administrator to add one in the system.' Below the note is a 'Role Type' dropdown menu with 'Installer' selected. There are input fields for Username, Country/Region, Time Zone, Email, and Password. At the bottom, there are three checkboxes for 'Agree (User Registration Agreement)', 'Agree (Enterprise and other third-party privacy policies)', and 'Agree to receive email notifications (New Products, Events, Information) Information on new product release, events, or news'. A blue 'Confirm Registration' button is at the bottom.

7.3. Perform the initialization settings

Prerequisite

The Bluetooth function on your mobile phone is enabled.

Procedure

1. Select your device
 - a. On the **Service** interface, select **Remote Configuration**.
 - b. Tap **Bluetooth** and then **Next Step**.
 - c. Tap your inverter according to the inverter serial number (SN).

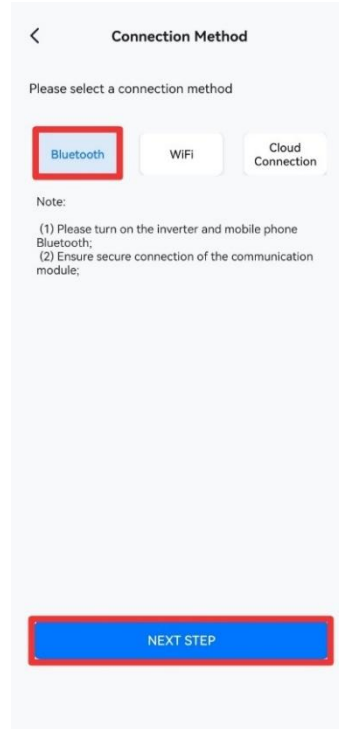
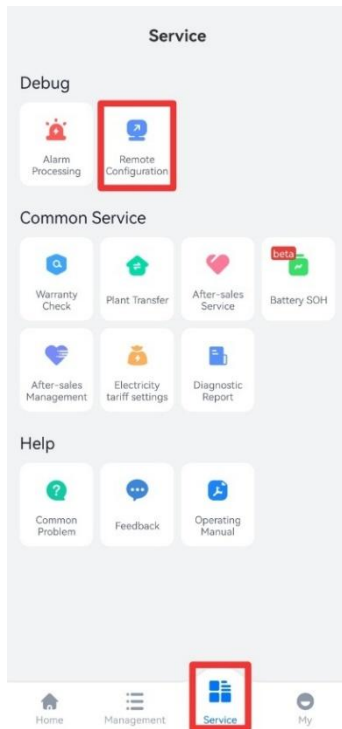

2. Complete the initialization settings by following the instructions on the screen.

a. Country and grid compliance settings

On **Local Connection** page, tap **Grid Code Settings**. Configure the following settings.

- **Country:** The country where the equipment is installed.
- **Grid Compliance:** The grid standard applicable to the installation.

Note: For Australia, select the specific compliance type based on the owner's local grid configuration.

- **Time Zone:** The time zone of the installation site.
- **Inverter Time:** Tap **AUTO TIME SYNC** to synchronize the device time with the time zone set in the App.

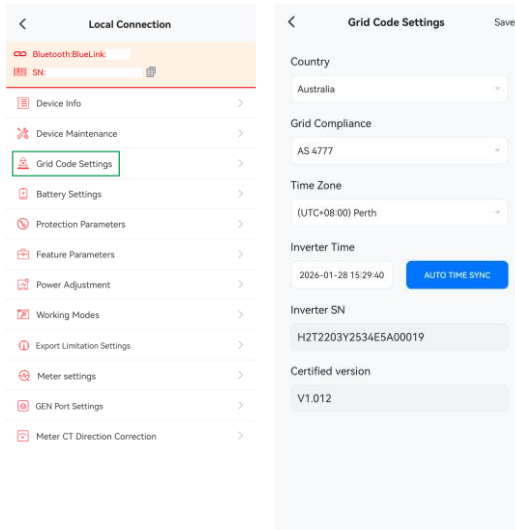

b. Battery brand and settings

On **Local Connection** page, tap **Battery Settings**. Configure the following settings.

- **Battery Brand:** select the battery type (Li-ion / Lead-acid) or battery brand (SAJ).
- **Battery Parameters:** configure the battery capacity, charging and discharging current, on-grid and off-grid discharge capacity lower limit, charge capacity upper limit, and SOC.

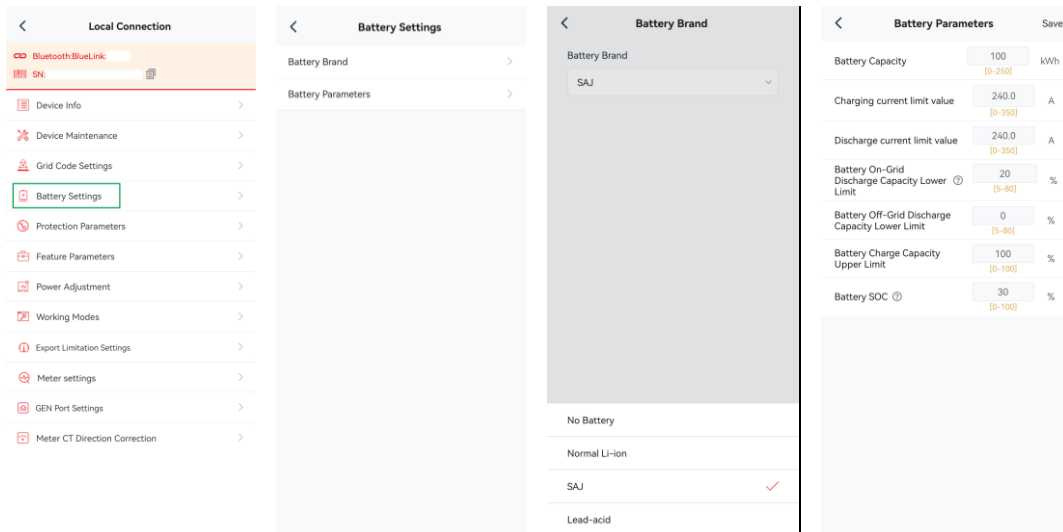

c. Protection parameters



On **Local Connection** page, tap **Protection Parameters**. The parameters are divided into two main groups for both voltage and frequency:

- **Protection Value:** The voltage (V) or frequency (Hz) threshold at which the inverter will begin its disconnecting procedure.
- **Disconnection Time:** The duration (usually in millisecond) the abnormal condition must persist before the inverter disconnects from the grid. This delay helps avoid unnecessary shutdowns during very short grid fluctuations.

Configure the following settings.

Grid Voltage Protection

- **Grid Overvoltage Protection Value / 2nd Level Grid Overvoltage Protection Value:** Sets the upper voltage limit(s). The 2nd level typically represents a more severe, higher threshold.
- **Grid Undervoltage Protection Value / 2nd Level Grid Undervoltage Protection Value:** Sets the lower voltage limit(s). The 2nd level typically represents a more severe, lower threshold.
- **Overvoltage Disconnection Time / 2nd Level Overvoltage Disconnection Time:** The delay before disconnection for overvoltage faults.
- **Undervoltage Disconnection Time / 2nd Level Undervoltage Disconnection Time:** The delay before disconnection for undervoltage faults.

Grid Frequency Protection

- **Grid Over-Frequency Protection Value / 2nd Level Grid Over-Frequency Protection Value:** Sets the upper frequency limit(s). The 2nd level typically represents a more severe, higher threshold.
- **Grid Under-Frequency Protection Value / 2nd Level Grid Under-Frequency Protection Value:** Sets the lower frequency limit(s). The 2nd level typically represents a more severe, lower threshold.
- **Over-Frequency Disconnection Time / 2nd Level Over-Frequency Disconnection Time:** The delay for over-frequency faults.
- **Under-Frequency Disconnection Time / 2nd Level Under-Frequency Disconnection Time:** The delay for the

under-frequency faults.

Local Connection

Bluetooth BlueLink

S/N

- Device Info >
- Device Maintenance >
- Grid Code Settings >
- Battery Settings >
- Protection Parameters >
- Feature Parameters >
- Power Adjustment >
- Working Modes >
- Export Limitation Settings >
- Meter settings >
- GEN Port Settings >
- Meter CT Direction Correction >

Protection Parameters Save

10 min. Overvoltage Protection Value	300.0	V
Grid Overvoltage Protection Value	280.0	V
Grid Undervoltage Protection Value	140.0	V
2nd Level Grid Overvoltage Protection Value	300.0	V
2nd Level Grid Undervoltage Protection Value	110.0	V
Grid Over-Frequency Protection Value	54.98	Hz
Grid Under-Frequency Protection Value	45.02	Hz
2nd Level Grid Over-Frequency Protection Value	55.00	Hz
2nd Level Grid Under-Frequency Protection Value	45.00	Hz

Overvoltage Disconnection Time	2000	ms
Undervoltage Disconnection Time	2000	ms
2nd Level Overvoltage Disconnection Time	100	ms
2nd Level Undervoltage Disconnection Time	100	ms
Over-Frequency Disconnection Time	200	ms
Under-Frequency Disconnection Time	200	ms
2nd Level Over-Frequency Disconnection Time	200	ms
2nd Level Under-Frequency Disconnection Time	200	ms

d. Feature parameters

 **WARNING**
 Modifying this setting without expert knowledge can compromise safety.

On **Local Connection** page, tap **Feature Parameters**. These parameters allow you to configure key functional and safety settings for your inverter.

- **Inverter Function Code:** Select the inverter function you want to enable. For detailed description of functions, refer to **Section** [错误未找到引用源。](#).
- **Inverter Grid Compliance Curve:** Select the grid standard mandated by your local utility or governing body.
- **Maximum DCI:** The upper limit for the direct current that the inverter will accept from the PV array. This value must be set according to the specifications of your installed PV modules and string configuration. It must not exceed the maximum DC input current stated in the technical datasheet.
- **Maximum Earth Leakage Current:** The threshold for earth leakage current detection. If the system detects leakage current to the ground exceeding this limit, the inverter will shut down to prevent electric shock hazards. This value should be configured in accordance with local electrical safety regulations.
- **Start-up Time:** The duration from when the inverter receives a start command until its output terminal establishes a stable and standard-compliant AC voltage.

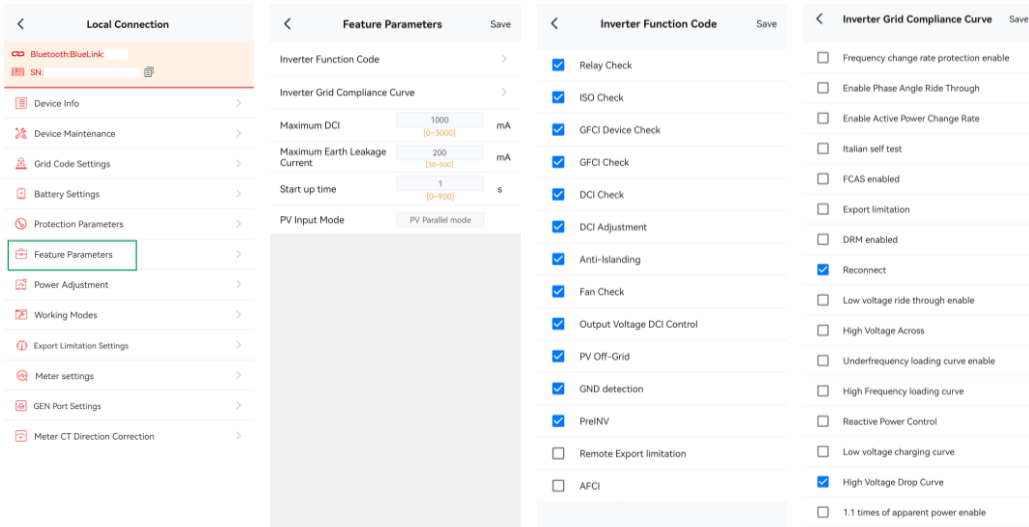

The screenshot displays the 'Feature Parameters' settings page. The 'Local Connection' sidebar on the left includes options like Bluetooth BlueLink, Device Info, Device Maintenance, Grid Code Settings, Battery Settings, Protection Parameters, **Feature Parameters** (highlighted), Power Adjustment, Working Modes, Export Limitation Settings, Meter settings, GEN Port Settings, and Meter CT Direction Correction. The main content area is divided into four sections:

- Feature Parameters:**
 - Inverter Function Code: >
 - Inverter Grid Compliance Curve: >
 - Maximum DCI: 1000 mA (range: 0-3000)
 - Maximum Earth Leakage Current: 200 mA (range: 10-500)
 - Start up time: 1 s (range: 0-900)
 - PV Input Mode: PV Parallel mode
- Inverter Function Code:**
 - Relay Check
 - ISO Check
 - GFCI Device Check
 - GFCI Check
 - DCI Check
 - DCI Adjustment
 - Anti-Islanding
 - Fan Check
 - Output Voltage DCI Control
 - PV Off-Grid
 - GND detection
 - PreINV
 - Remote Export limitation
 - AFCI
- Inverter Grid Compliance Curve:**
 - Frequency change rate protection enable
 - Enable Phase Angle Ride Through
 - Enable Active Power Change Rate
 - Italian self test
 - FCAS enabled
 - Export limitation
 - DRM enabled
 - Reconnect
 - Low voltage ride through enable
 - High Voltage Across
 - Underfrequency loading curve enable
 - High Frequency loading curve
 - Reactive Power Control
 - Low voltage charging curve
 - High Voltage Drop Curve
 - 1.1 times of apparent power enable

- **PV Input Mode:**

- **PV Auto Mode**

The inverter automatically detects the voltage and current characteristics of all connected PV strings.

If it detects highly consistent electrical characteristics (such as voltage and current curves) across all MPPT inputs, it automatically switches to **parallel mode** to simplify operation.

If it detects significant differences in input characteristics (such as varying voltages or different peak power points), it automatically operates in **independent mode** to maximize power generation.

- **PV Independent Mode:**

Select this if strings are connected to different MPPT inputs. This allows each MPPT to operate independently at its optimal point for maximum energy harvest.

- **PV Parallel Mode**

In this mode, the inverter internally “virtually parallels” multiple MPPT input channels, treating them as a single, unified, larger PV string. The inverter seeks only one global optimal power point.

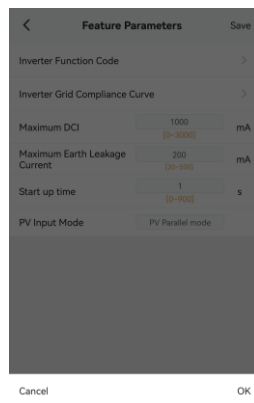

PV Auto Mode

PV Independent Mode

PV Parallel mode

e. Power adjustment

**NOTICE**

Once **Country and Grid Compliance** are selected during initialization, the parameters relating to the reactive power control settings are set automatically. In typical household scenarios, the default values require no adjustment. If adjustment is necessary, before any modifications, contact SAJ for consultation and ensure that you have the necessary electrical knowledge and are fully aware of the impact of such modifications.

On **Local Connection** page, tap **Power Adjustment**. This interface provides control over the inverter's reactive power output. The power adjustment methods are divided into four main groups.

- ① The plant operates at a fixed reactive power value (applicable when the grid company requires a specific reactive power value).
 - **Capacitive Adjustment (Var):** The inverter generates reactive power. This can elevate the local grid voltage at its connection point.
 - **Inductive Adjustment (Var):** The inverter absorbs reactive power. This can reduce the local grid voltage at its connection point.
- ② The inverter automatically adjusts capacitive/inductive reactive power output to maintain a fixed power factor (applicable when requiring compensation for lagging power factor)
 - **Capacitive Power Factor Adjustment:** Maintains a “leading” power factor (e.g., 0.9), meaning the inverter consistently generates a fixed amount of capacitive reactive power.
 - **Inductive Power Factor Adjustment:** Maintains a “lagging” power factor (e.g., 0.9), meaning the inverter continuously generates a fixed amount of inductive reactive power.
- ③ The inverter automatically adjusts reactive power output based on real-time grid voltage levels. (Applicable for unstable grid voltage)
 - **Voltage-Reactive Power Curve:** Set a curve, e.g., specifying zero reactive output at normal voltage; when voltage rises, the inverter begins absorbing inductive reactive power (assisting voltage reduction); when voltage drops, the inverter begins generating capacitive reactive power (assisting voltage increase).
 - **Curve Mode: Preset curve.**
- ④ **Off:** The inverter performs no reactive power regulation and outputs only active power (power factor = 1).

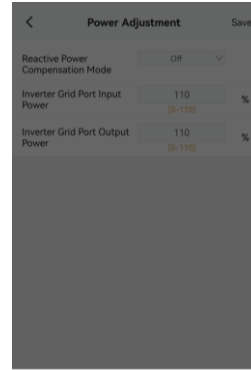
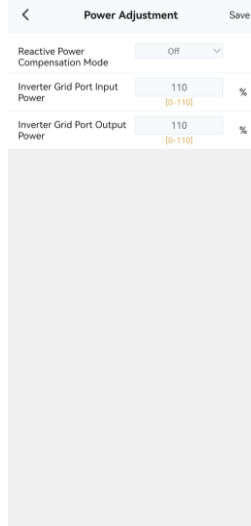
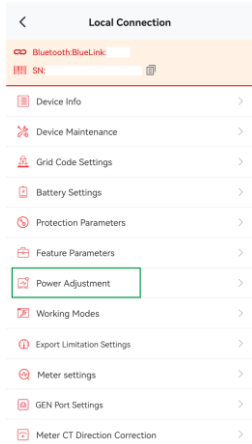

Cancel OK

Capacitive Adjustment (Var)

Inductive Adjustment (Var)

Inductive Adjustment (Var)

Capacitive Power Factor Adjustment

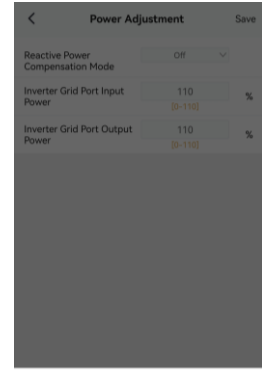

Cancel OK

Capacitive Power Factor Adjustment

Inductive Power Factor Adjustment

Voltage-Reactive Power Curve

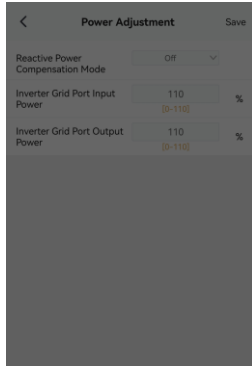

Cancel OK

Capacitive Power Factor Adjustment

Inductive Power Factor Adjustment

Voltage-Reactive Power Curve

Curve Mode

Off

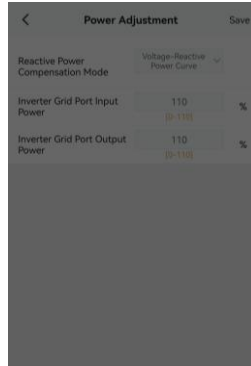

Cancel OK

Inductive Power Factor Adjustment

Voltage-Reactive Power Curve

Curve Mode

Off

f. Working modes

On **Local Connection** page, tap **Working Modes**.

- **Current Mode:** Select the desired mode: self-consumption mode, time-of-use pricing mode, time-of-use mode (BMS), back-up mode, or peak-shaving mode. Check the pop-up window information to ensure full understanding of the chosen working mode. For detailed explanation of each working mode, refer to the section **2.2 Working modes** of the manual.

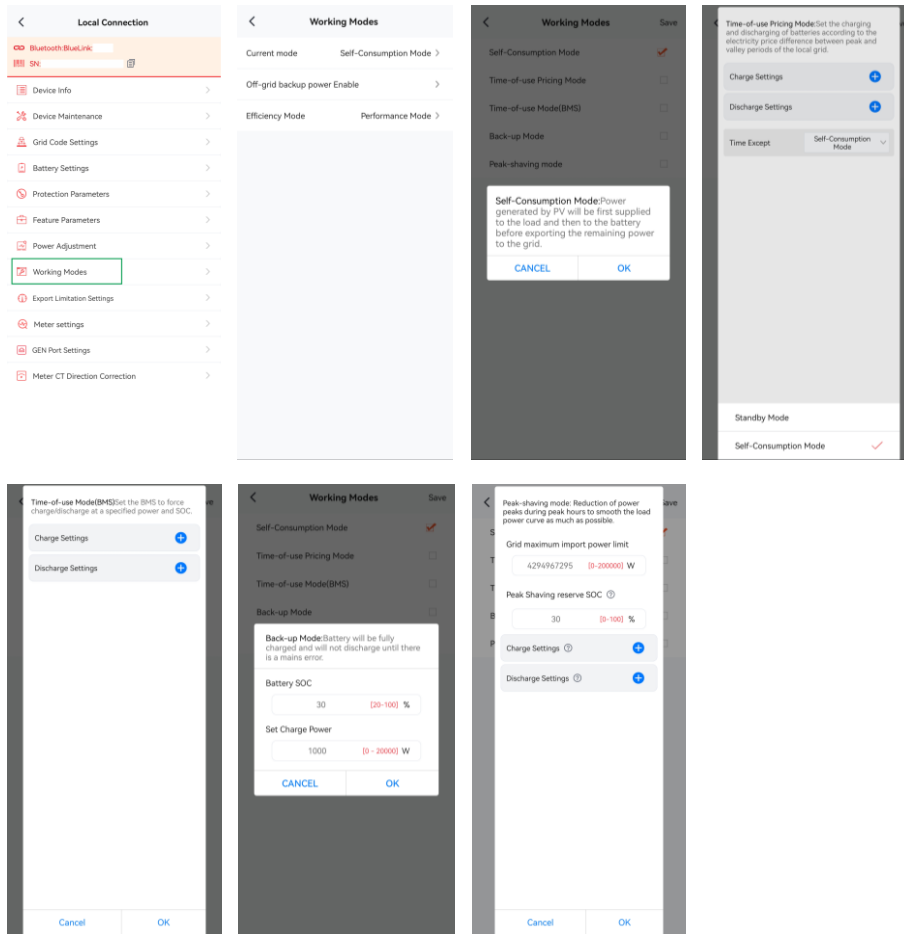

- **Off-grid backup power enable:** When enabled, upon detecting a grid power outage, the system automatically switches to battery power for backup loads. Ensures uninterrupted power for critical loads during mains power interruptions.

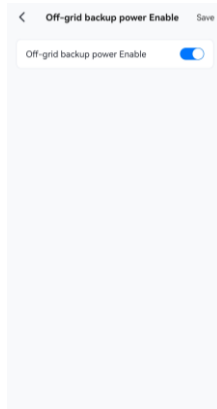

- **Efficiency Mode**

- **Performance mode:** The power station will maintain operation, resulting in higher self-consumption. Applicable for peak power consumption periods or times requiring rapid responsiveness.
- **Power saving mode:** The battery in low-power states and wakes on demand. Applicable for off-peak usage periods or when the device remains idle for extended periods.

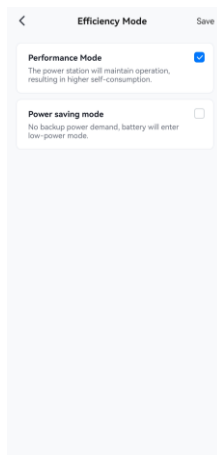

g. Export limitation settings

On **Local Connection** page, tap **Export Limitation Settings**.

- On-Grid Three-Phase Unbalanced Output:** To enable three-phase unbalanced output. When this function is enabled, one phase can receive power far exceeding the average (up to 100% of the system's available power), thereby prioritizing solar energy to drive large loads on the one phase.
- Export Limitation Settings**
 - Phase power: Limit the power export to the grid by each phase.
 - Phase current: Limit the current export to the grid by each phase.
 - Total power: Limit the total three-phase power export to the grid.
- Time-of-use export limitation:** Limit the total power export to the grid at different times of the day.

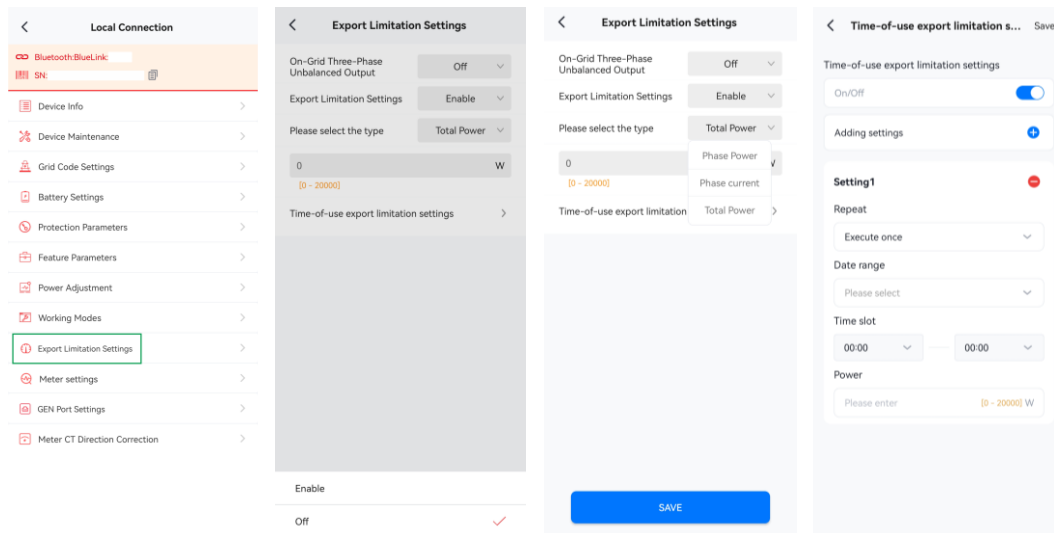

h. Meter Settings

On **Local Connection** page, tap **Meter Settings**.

Select wiring method and the corresponding system schematic will be shown below.

The image displays three sequential screenshots of the 'Meter settings' application interface, illustrating the process of selecting a wiring method and viewing the corresponding system schematic.

- Left Screenshot:** Shows the 'Local Connection' menu with 'Meter settings' highlighted in green. The 'Meter settings' screen shows 'Wiring Method' set to 'No Meter'.
- Middle Screenshot:** Shows 'Wiring Method' set to 'One Three-Phase Four-Wire Meter'. The 'System Schematic' below shows a three-phase system with a DC/AC converter, a backup inverter, and a grid connection.
- Right Screenshot:** Shows 'Wiring Method' set to 'CT'. The 'System Schematic' below shows a similar three-phase system but with a current transformer (CT) connected to the meter.

i. GEN Port Settings

On **Local Connection** page, tap **GEN Port Settings**.

- **Port Access Enable:** Select the function of the GEN port according to the device you connect.
 - **Diesel Generator:** Connect this port to an external diesel generator. It will serve as a backup power source when solar generation is insufficient and the battery is depleted.
 - **Smart Load:** Connect this port to high-power, non-essential loads, which will consume excess solar power. When the system is on battery power with low charge, it will prioritize shutting down these smart loads to ensure other critical loads remain powered.
 - **PV Inverter:** Connect this port to on-grid inverter. This setup is used when retrofitting an energy storage system to an existing PV system (AC-coupling), allowing the hybrid inverter to connect with the on-grid inverter.

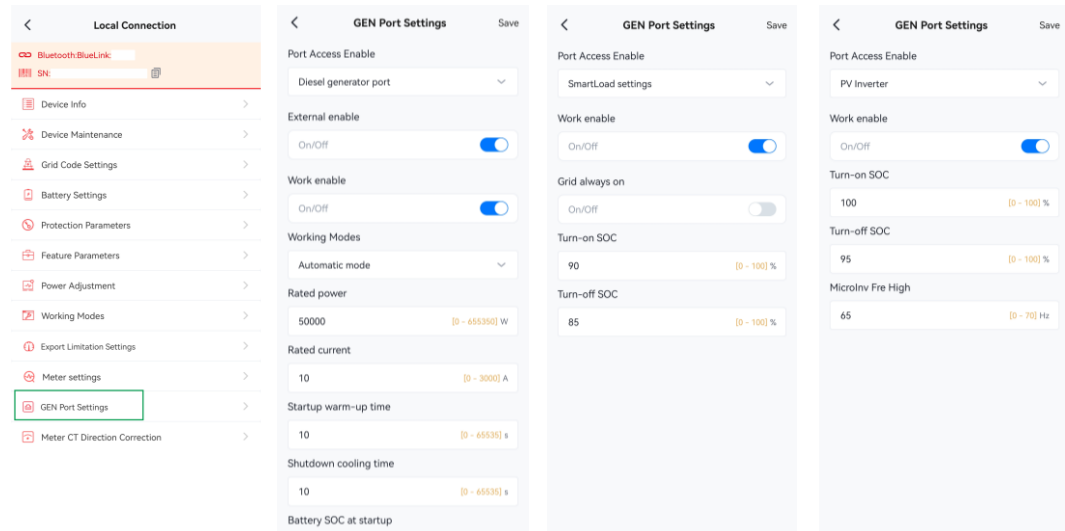

j. Meter CT Direction Correction

On **Local Connection** page, tap **Meter CT Direction Correction**.

This function helps to correct the installation direction of the Current Transformer (CT), which is crucial for accurate power flow measurement.

For proper operation, the CT must be installed with its arrow pointing toward the inverter and on-grid loads. If the CT is found to be installed in reverse, the direction can be corrected directly within the App. No physical reinstallation of the CT is required.

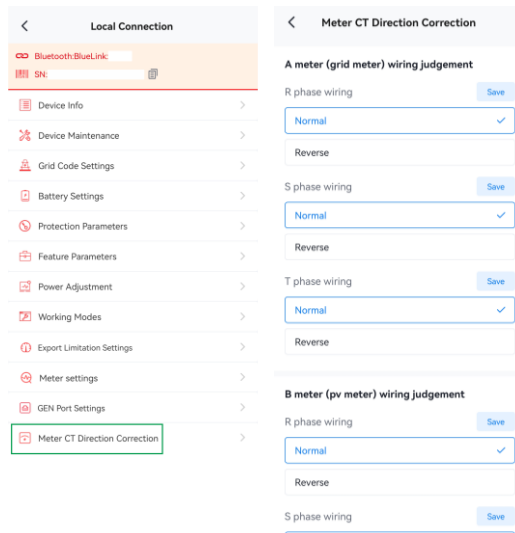

7.4. Configure the communication module

About this task

If you want to remotely monitor the energy storage system and view the device statistics (for example, when you are away from home), connect the communication module installed on the inverter to the network.

Procedure

1. On the **Device List** page, select your communication module according to its SN.
2. Tap the setting icon  on the upper right corner.
3. Select **WiFi Configuration** and set the communication module to connect to your home network.

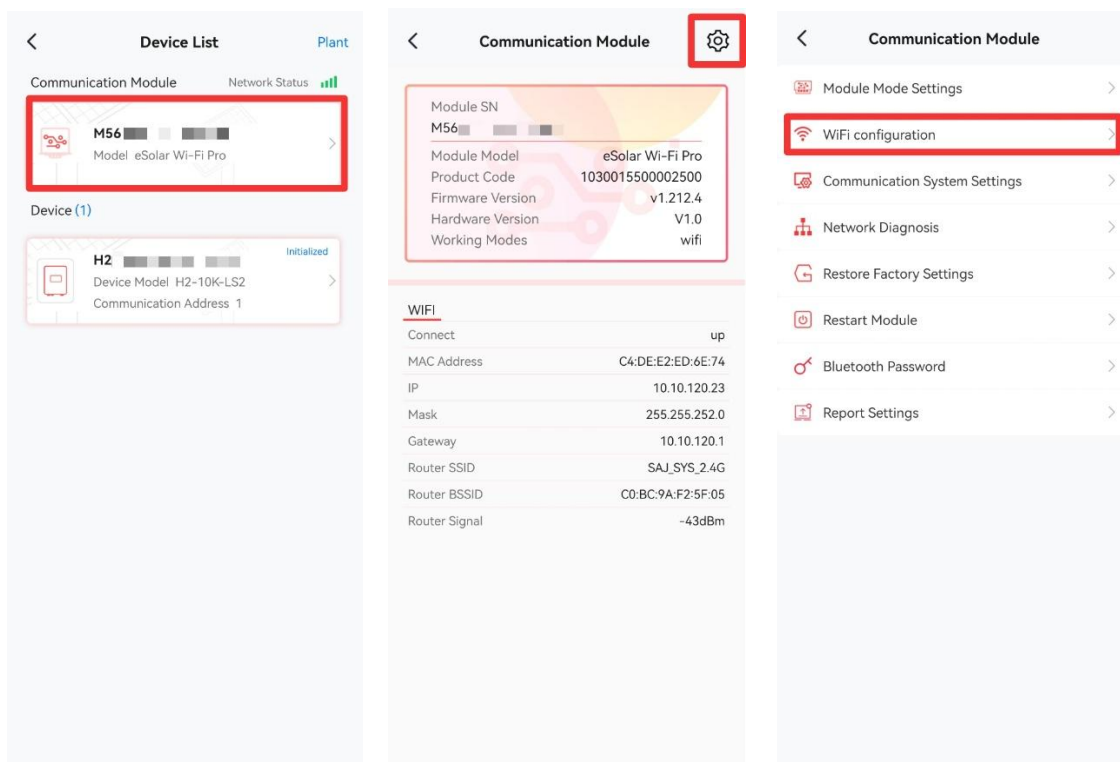

7.5. Create a plant

1. On the **Management** page, tap the \oplus icon on the top right corner. Select **Create Plant for Owner**.

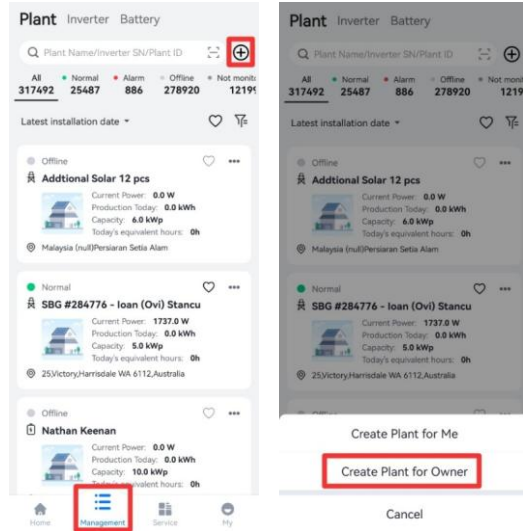

2. Apply for an account for the end user and create a plant.

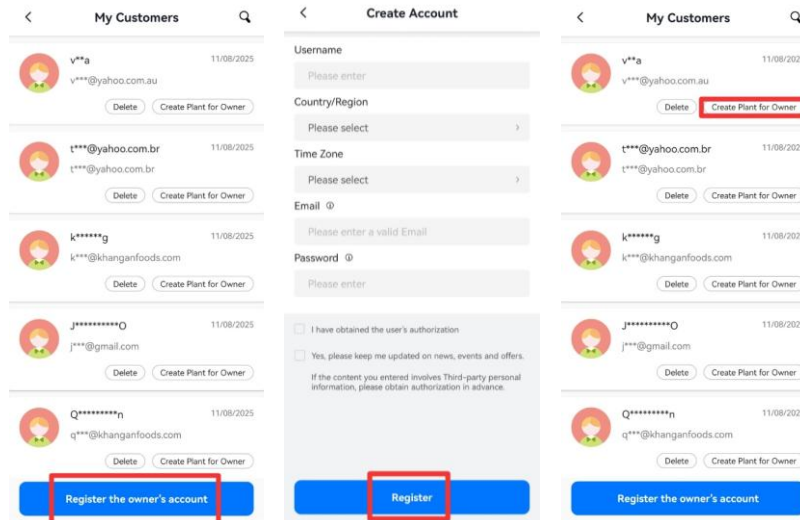

3. Configure the plant details.

The image displays two sequential screenshots of a mobile application's 'Add' screen for configuring plant details.

Left Screenshot: The 'Add' screen shows a form with the following fields and options:

- Plant Owner: [Redacted]
- Name: Test demo plant
- Capacity: 10 kWp
- Country/Region: Germany
- Plant Time Zone: (UTC+01:00) Amsterdam, Berlin, Bern...
- Plant Address: [Redacted]
- Use Type: Home Use
- Number of Components: Please enter
- PV Panel Azimuth: [Redacted]

At the bottom, there are two buttons: 'Previous' (disabled) and 'Create Plant' (active, highlighted with a red box).

Right Screenshot: The 'Add' screen shows a form with the following fields and options:

- Plant Owner: [Redacted]
- Please enter the SN: [Redacted]
- Supports inverter SN/SEC Module SN/EMS SN: [Redacted]
- Device 1: [Redacted]
- SN: HS [Redacted]
- Device Capacity: 10 kWp

At the bottom, there is a 'Next' button (active, highlighted with a red box).

7.6. View the fixed power factor mode and fixed reactive power mode



NOTICE

Once **Country and Grid Compliance** are selected during initialization, the parameters relating to the reactive power control settings are set automatically. In typical household scenarios, the default values require no adjustment. If adjustment is necessary, before any modifications, contact SAJ for consultation and ensure that you have the necessary electrical knowledge and are fully aware of the impact of such modifications.

To view the settings, perform as follows:

On the **Local Connection** page, tap **Power Adjustment > Reactive Power Compensation Mode**.

- Fixed power factor mode

Select **Capacitive Power Factor Adjustment** or **Inductive Power Factor Adjustment**.

The power factor range is from 0.8 leading to 0.8 lagging.

- Fixed reactive power mode

Select **Capacitive Adjustment (Var)** or **Inductive Adjustment (Var)**.

The power ranges from $-60\% P_n$ to $60\% P_n$.

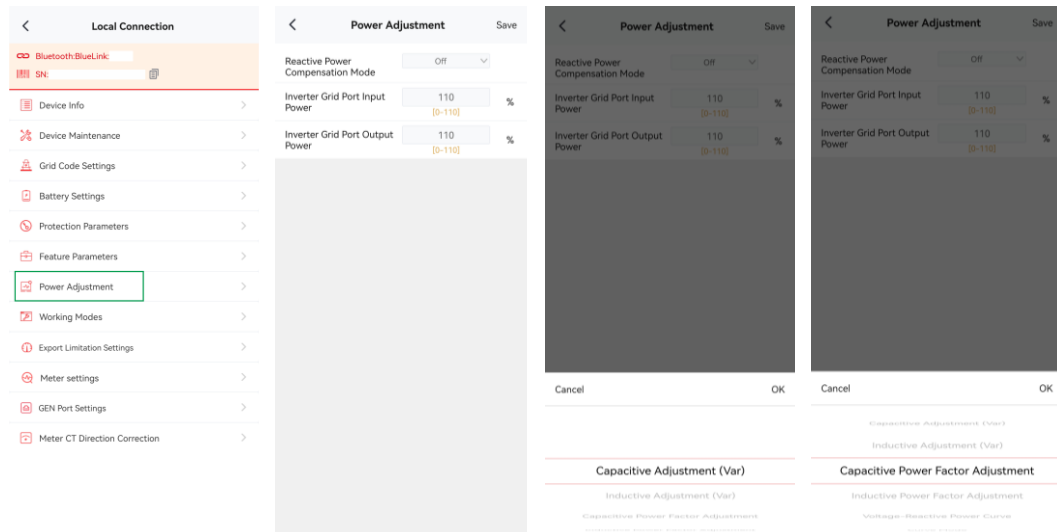

8.

COMMISSIONING ON THE LCD



If the network connection is unavailable or unstable, you can configure the ESS on the touchscreen Liquid Crystal Display (LCD) on the front panel of the inverter. Alternatively, on the LCD, you can also view the settings that you configured on the elekeeper App and current working data of the ESS.

8.1. Operations on the main screen

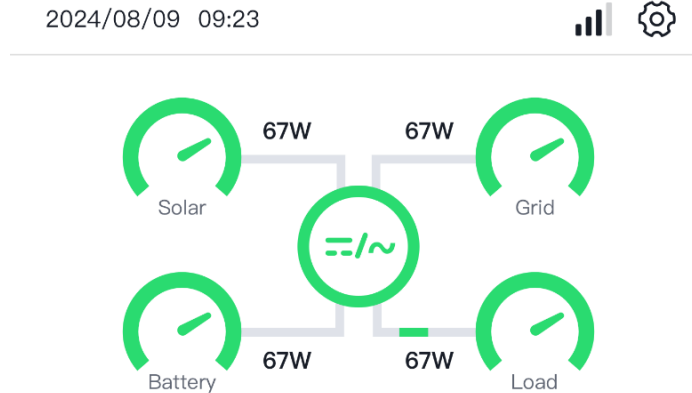

The main screen provides access to information about the inverter, solar, grid, battery, and loads. In addition, it illustrates the energy flow direction.

-  in the center of the screen: Inverter information
It can be displayed in one of the following statuses:

Color	Status	Description
Green	Running	The system is working properly.
Red	Error	An error has occurred.
Yellow	Alarm	An alarm is reported.
Blue	Upgrading	The system is upgrading.

Tap this icon to view the following:

- Working mode
- Current warning
- History warnings

-  **Solar:** PV array information

Tap this icon to view the following:

- Generated power
- Today's energy
- Total energy
- Voltage, current, and power of current PV arrays

●  **Grid:** Grid information

Tap this icon to view the following:

- Status
- Power
- Frequency
- Voltage
- Current
- Power imported from the grid (today's data and total data)
- Power exported to the grid (today's data and total data)

●  **Battery:** Battery information

Tap this icon to view the following:

- Brand
- Status
- Capacity
- SOC
- Voltage
- Current
- Temperature

●  **Load:** Load information

Tap this icon to view the following:

- Runtime of current home loads on the battery power in off-grid status
- Load voltage
- Load current
- SmartLoad power (It is displayed only when **SmartLoad Settings** is selected in **Port Access Enable**.)

8.2. Settings

To configure system parameters via the LCD interface, perform as follows.

Step 1. Tap the setting icon  on the top right corner of the main screen.

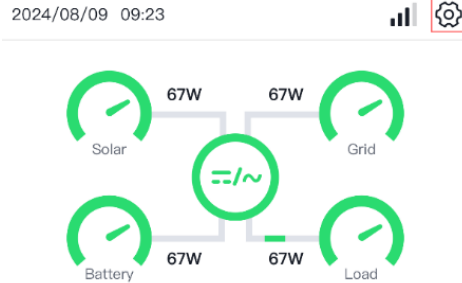

Step 2. Enter the default password and press the **ENT** key to access the settings menu.

Note: Contact the installer or SAJ technical support to obtain the password.

The key functions of the on-screen keypad are as follows.

- 0-9: Input digits.
- Esc: Cancel and exit.
- Del: Delete last character.
- CE: Clear all input.
- ENT: Submit password.

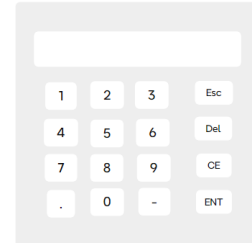

Step 3. Access the settings menu successfully and start configuring system parameters as required.

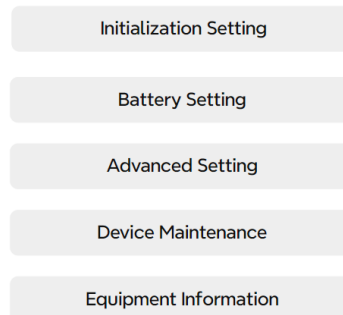

8.2.1. Initialization setting

All the initialization parameters can be set through this interface. The interface includes the following content:



Note:

- **Working modes > Back-up mode > When using lithium battery > Battery SOC & Charge power**

This option requires users to configure a set value for battery SOC.

When the battery SOC is lower than the configured SOC value, the batteries can only be in charging status at preset charging power.

When the battery SOC reaches the configured SOC value, the batteries will stop charging.

When the battery SOC is higher than the configured SOC value, the inverter will work in self-consumption mode.

- For Working modes > Back-up mode > When using lead-acid battery > Backup voltage & Charge power

This option requires users to configure a set value for battery voltage.

When the battery voltage is lower than the configured voltage value, the batteries can only be in charging status at preset charging power.

When the battery voltage reaches the configured voltage value, the batteries will stop charging.

When the battery voltage is higher than the configured voltage value, the inverter will work in self-consumption mode.

8.2.2. Battery setting

Set the battery-related parameters based on your needs.

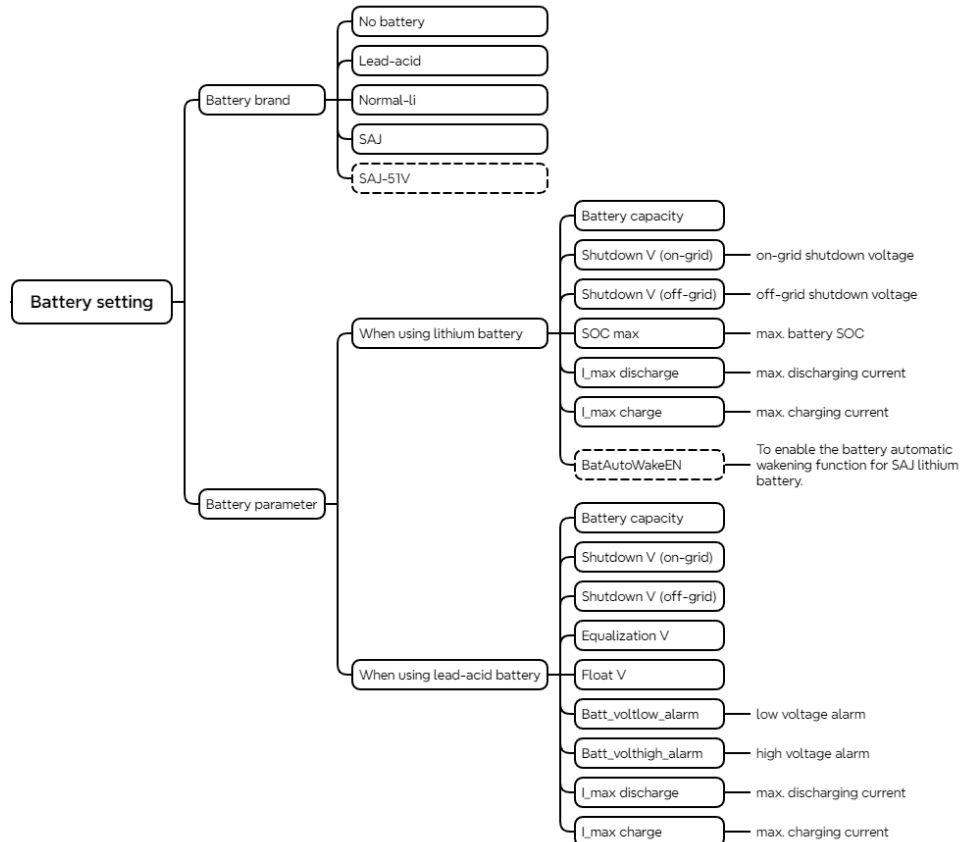

8.2.3. Advanced settings

Set the inverter-related advanced setting based on your needs.

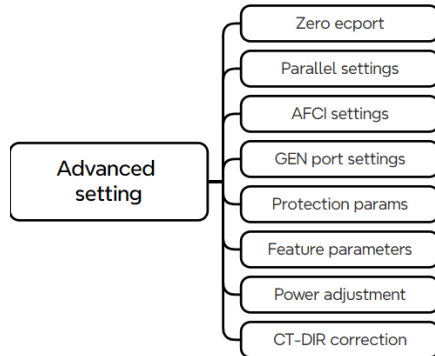

8.2.3.1. Zero export

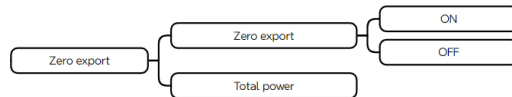

When **Zero Export** is enabled, set **Total Power** to limit the maximum power exported to the grid.

8.2.3.2. Parallel settings

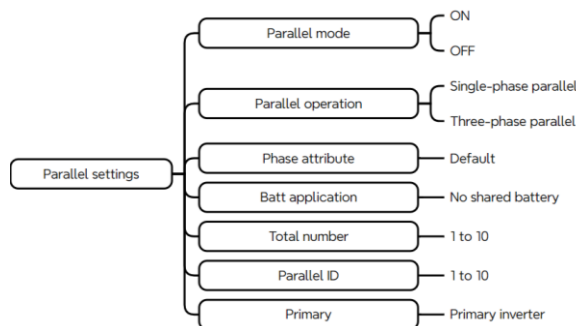

By default, the inverter configured with **Parallel ID 1** will work as the primary device (in the **Primary** operation mode). If you assign **Primary** mode to another inverter (for example, **Parallel ID 2**), the device configured with **Parallel ID 1** will switch to **Secondary mode**.

8.2.3.3. AFCI settings (optional)

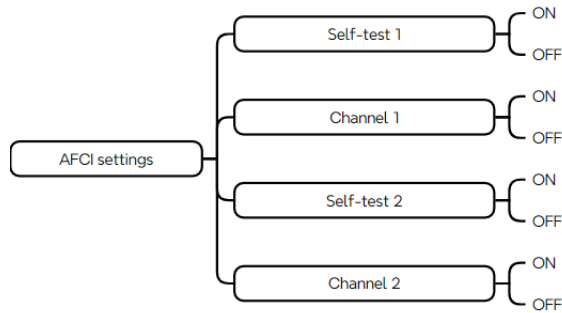

With the Arc-fault circuit-interrupter (AFCI) protection, when there is an arc signal on the DC side due to aging of the cable or loose contact, the inverter can quickly detect it and cut off the power to prevent fire and ensure the PV system safety.

The AFCI protection works only when **Self-test** and **Channel** are both enabled.

8.2.3.4. GEN port settings

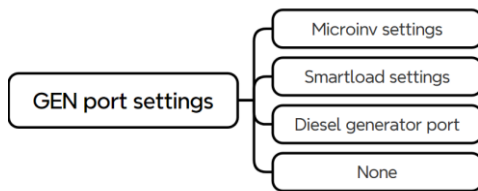

In **GEN port setting**:

- **MicroInv setting:**

This setting manages microinverter operation during off-grid by intelligently adjusting the system frequency to prevent overload.

- **SmartLoad setting:**

If selected, the connected household load will start and stop working based on the **Turn-on SOC** and **Turn-off SOC** values.

- **Diesel generator port:**

If selected, the connected generator will output its generated power to household loads through this port.

- **None:**

No setting is required.

8.2.3.5. MicroInv Settings

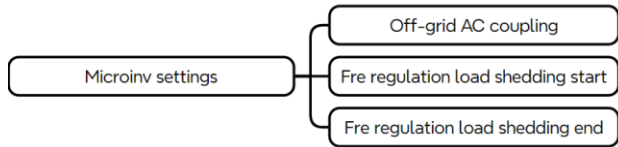

- **Off-grid AC coupling:** This function enables the hybrid inverter to establish a stable microgrid during a grid outage, allowing the microinverters to continue operating and generating power.
- **Freq regulation load shedding start:** During off-grid period, when excess power is generated, the system frequency will be raised to signal the microinverter to reduce its power output and prevent system overvoltage.
- **Freq regulation load shedding end:** Stop raising the system frequency to allow the microinverter to generate power normally.

8.2.3.6. Smartload settings

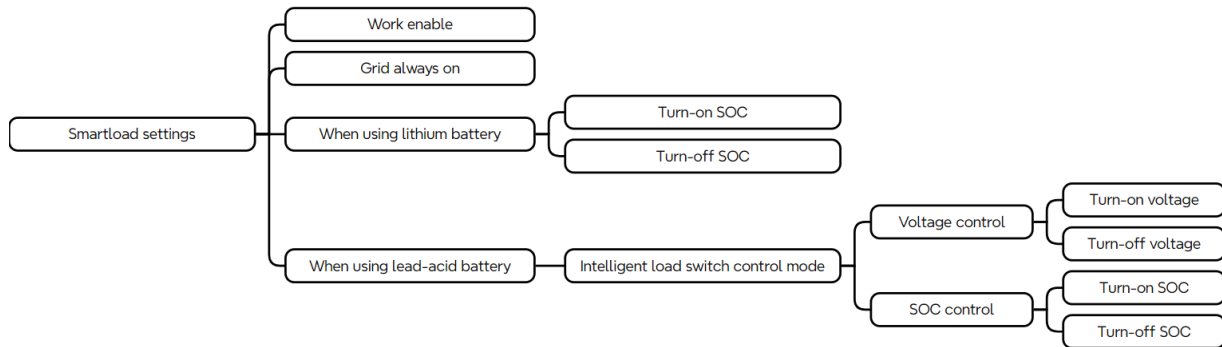

- **Work enable:** To enable or disable the smart load.
- **Grid always on:**
If enabled, the connected smart loads keep working as long as the grid power is detected, regardless of the battery SOC or voltage. If disabled, this device might not work even if the grid power is detected.
- **When using lithium battery:** the connected household load will start and stop working based on the Turn-on SOC and Turn-off SOC values.
- **When using lead-acid battery:** the connect household load will start and stop working based on Turn-on voltage/SOC and Turn-off voltage/SOC.

8.2.3.7. Diesel generator port

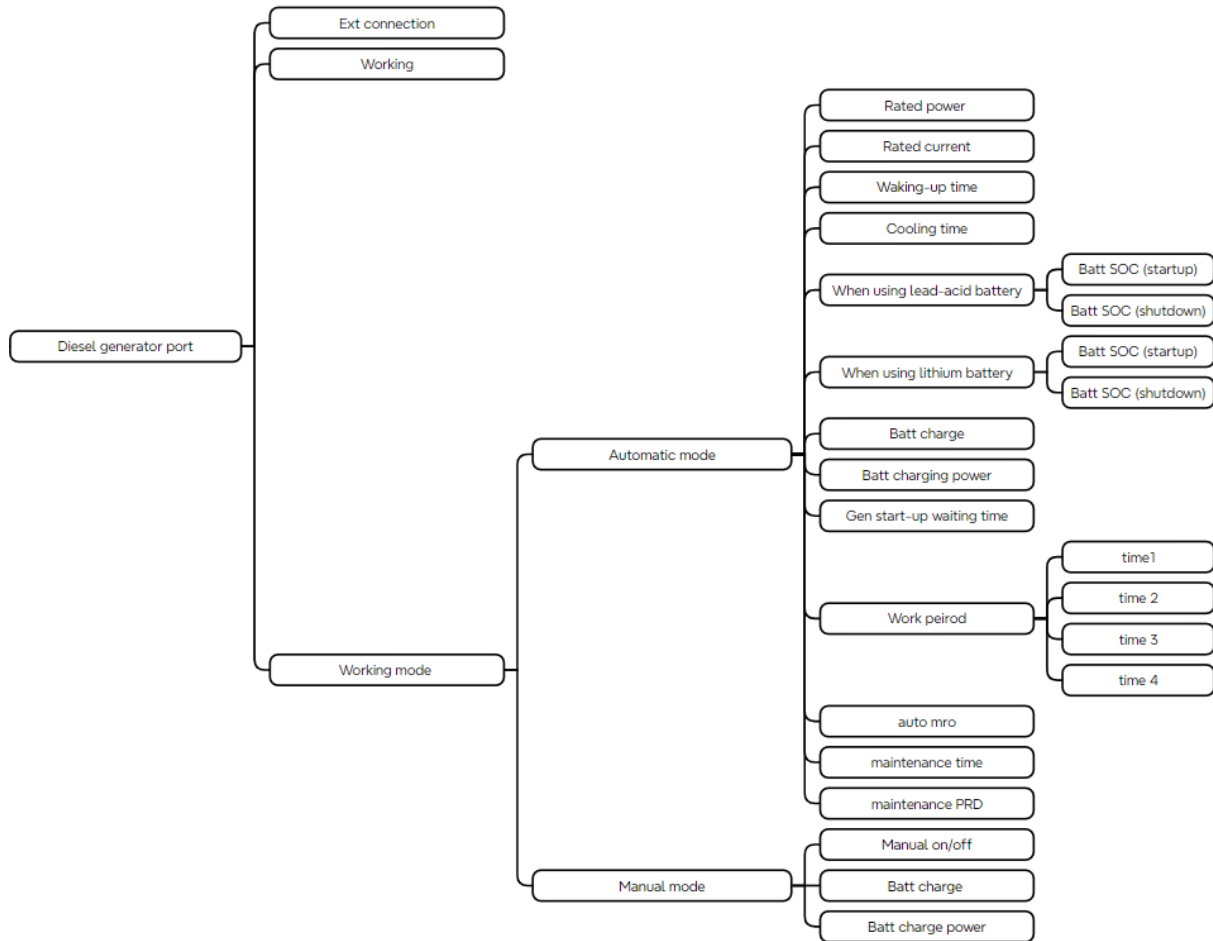

In **Working mode**:

- **Automatic mode:** If you select this mode, the generator will work based on the settings. For example, **BATT charge** in ON status indicates that the power generated by the generator will be used for battery charging.
- **Auto MRO:** Automatic maintenance and protection function.
- **Maintenance PRD:** Maintenance once per N days.

8.2.3.8. Protection parameters

Configure the multi-level protection settings here, including thresholds and disconnection times for overvoltage, undervoltage, over-frequency, and under-frequency conditions.

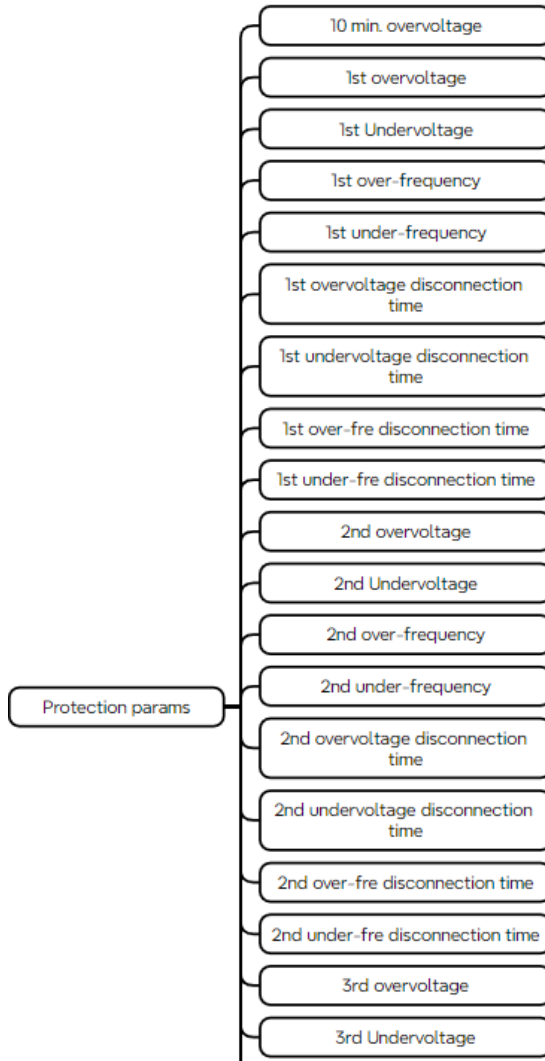

8.2.3.9. Feature parameters

Configure feature parameters of the inverter, including safety checks, grid compliance, power control, and operational modes.

Parameter Name	Description	Function
Relay check	Relay Detection Enable	Enables fault detection for the relay circuit.
ISO check	ISO Detection Enable	Enables isolation detection, which monitors the insulation resistance value between the PV system and ground.
GFCI dev-check	Earth Leakage Self-Test Enable	Enables the self-diagnostic function for the earth leakage current detection system.
GFCI check	Earth Leakage Detection Enable	Enables continuous monitoring for earth leakage current faults.
DCI check	Grid Current DC Component Detection Enable	Enables detection of DC offset in the grid current.
DCI adjust	Grid Current DC Component Control Enable	Suppress the grid current DC offset.
Anti-islanding	Active Islanding Detection Enable	Enables the active method for detecting an islanding condition (grid loss).
Fan check	Fan Detection Enable	Enables monitoring of the cooling fan status.
Output DCI ctr	Output Voltage DC Component Detection Enable	Enables detection of DC offset in the inverter's output voltage.
PV off-grid	PV Independent Load Support Enable	Allows the inverter to power loads from the PV array during off-grid.
Gnd detection	Grounding Detection Enable	Enables the system to detect and verify proper equipment grounding
Preinv	Pre-inverter Enable	Activates the initialization, self-checks, and circuit preparation operation before connecting to the grid.
Remexport limit	Remote Anti-Reverse Power Flow Enable	Enables the remote-control function to prevent power from being fed back to the grid.
AFCI	AFCI (Arc Fault Circuit Interrupter) Enable	Activates the Arc Fault Circuit Interrupter function to detect and respond to dangerous electrical arcs.

Frequency change rate protection	Frequency Change Rate Protection	Enables protection against excessively rapid changes in grid frequency. The inverter will disconnect if the frequency changes faster than the set rate to stabilize the grid during sudden generation or load loss.
Phase angle ride through	Phase Angle Ride Through	Allows the inverter to remain connected and operational during sudden, large shifts in the grid voltage phase angle.
Active power change rate	Active Power Change Rate	Enables control over the ramp rate of the inverter's real power output to prevent sudden power surges or drops that could shock the grid during startup, shutdown, or rapid changes in sunlight.
Italian self-test	Italian Self-Test	Activates the specific automatic test required by the Italian grid code.
FCAS	Frequency Control Ancillary Services (FCAS)	Enables the inverter to receive and respond to automatic dispatch signals to adjust its power output, helping to regulate the grid's frequency.
Export limit	Export Limit (Anti-Reverse Power Flow)	Activates an export limit to prevent power from being fed back to the grid.
DRM enable	DRM Enable	Enables the inverter to respond to demand signals, which can control its active and reactive power output to maintain grid stability and efficiency.
Reconnect	Reconnect	Allows the inverter to automatically reconnect to the grid after a protective shutdown
Low voltage ride through	Low Voltage Ride Through	Enables the inverter to remain connected and support the grid by injecting reactive current during periods of low grid voltage (e.g., during a fault).
High voltage ride through	High Voltage Ride Through	Enables the inverter to remain connected and operational during periods of abnormally high grid voltage.
Underfrequency loading curve	Under-frequency Loading Curve	Enables the inverter to increase its real power output when the grid frequency drops below the nominal value to help raise the frequency.
Over-frequency loading curve	Over-frequency Loading Curve	Enables the inverter to decrease its real power output when the grid frequency rises above the nominal value to help lower the frequency.
Reactive power control	Reactive Power Control	Enables advanced control modes for reactive power output. Used for grid voltage support, power factor correction, and to meet specific utility requirements.

Undervoltage charging curve	Under-voltage Charging Curve	Enables the battery to charge from the grid when the AC voltage is below a set threshold.
Over-voltage drop curve	Over-voltage Drop Curve	Enables the inverter to reduce its real power output when the grid voltage rises above a set point to help lower the voltage.
1.1 times of apparent power	1.1 Times Apparent Power Overload	Allows the inverter to operate continuously at up to 110% of its rated apparent power (kVA) for a defined period, providing additional overload capacity.
Maximum DCI	Maximum DC Input Current Limit	Set the maximum DC current value the inverter is permitted to receive from a single PV string.
Connect time	Grid Connection Delay	Sets the waiting time for the inverter after DC input start-up and self-tests are completed, before it attempts to connect to the grid and begin feeding power.
Maximum earth leakage current	Earth Leakage Current Threshold	Sets the protection trip point for the inverter's continuous earth leakage monitoring. The inverter will shut down if leakage current exceeds this value.
PV input mode	PV Input Mode	Manually selects the connection topology for the PV strings.
PV auto mode	PV Auto-Detection Mode	When enabled, the inverter automatically detects the number and wiring configuration of the connected PV strings.
PV independent mode	PV Independent MPPT Mode	When enabled, the inverter's multiple MPPT trackers operate independently.
PV parallel mode	PV Parallel Input Mode	When enabled, the inverter allows two or more PV strings to be internally paralleled into a single MPPT input.

8.2.3.10. Power adjustment

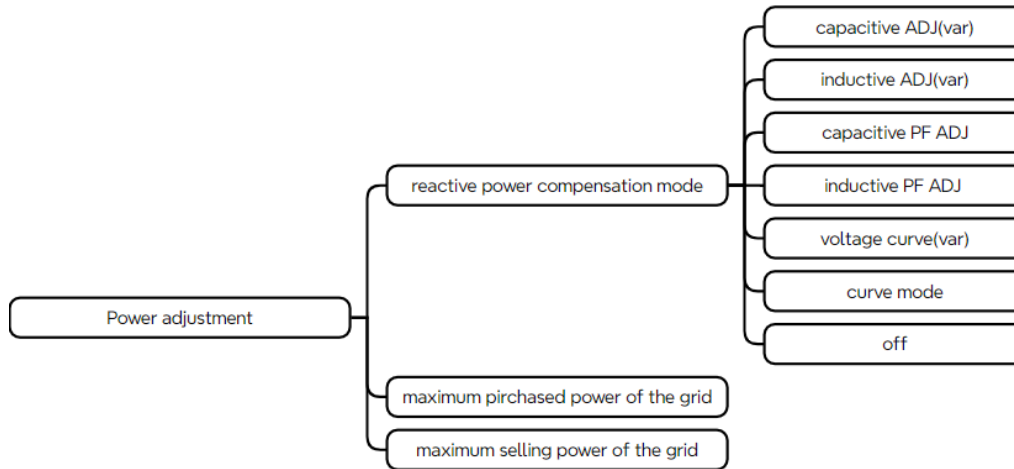

- **Inductive PF ADJ:** Automatically generates capacitive reactive power to correct an inductive power factor.
- **Capacitive PF ADJ:** Automatically generates inductive reactive power to correct a capacitive power factor.
- **Inductive ADJ (var):** Set a fixed value of inductive reactive power for the system to absorb.
- **Capacitive ADJ (var):** Set a fixed value of capacitive reactive power for the system to generate.

8.2.3.11. CT-DIR correction

Set the current transformer direction for both grid-side and PV-side connections to ensure accurate power flow measurement.

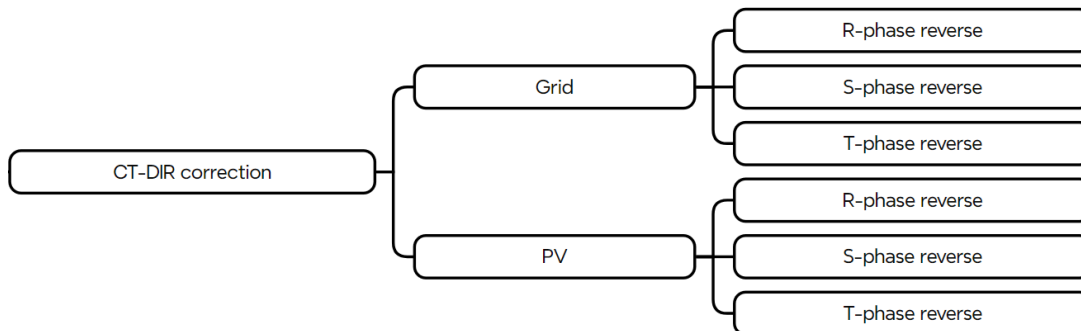

8.2.4. Device setting

Perform various device maintenance operations here, including system resets, data clearance, error log management, and operational controls.

Note: All the configurations will be lost after the **Reset** operation.

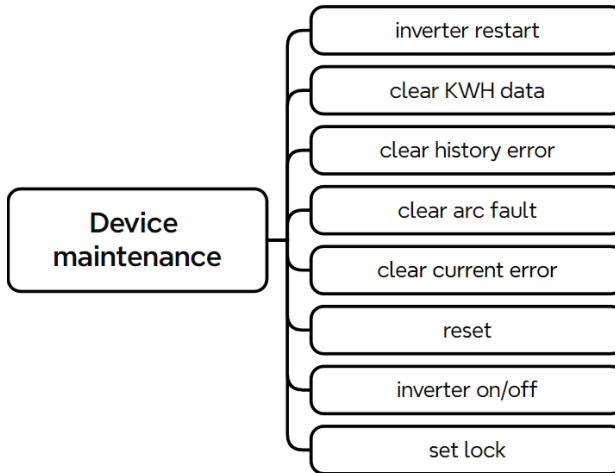

8.2.5. Equipment information

View the details about the inverter.

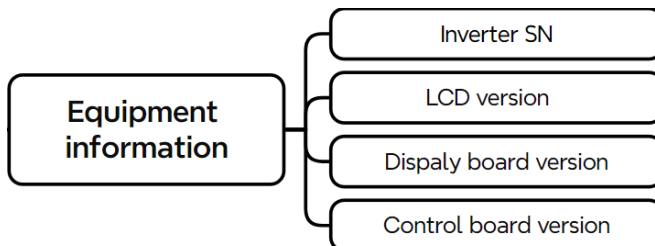

9.

TROUBLESHOOTING



On the elekeeper App, users may check the alarm details through **Home > Message > Alarm Message > All > Inverter > Alarm Details**.

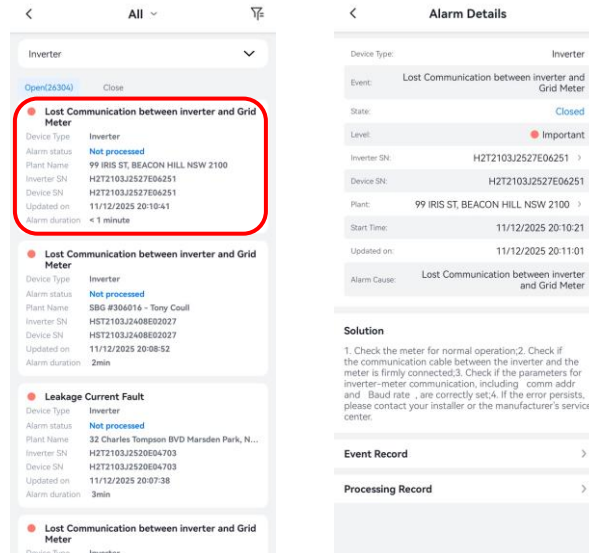
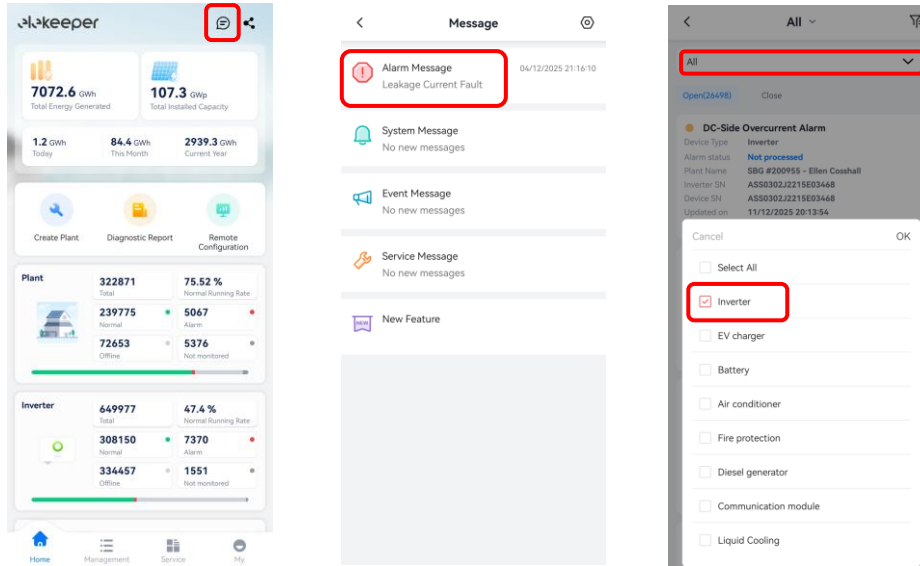

For any alarm reported on the APP, check the **Alarm Details** page for the possible cause and suggested troubleshooting actions. You may also refer to the summary list below. If the error persists after following the suggested solutions, or if no specific action is provided, contact your installer or the SAJ Electric service hotline for further assistance.

Error Code	Message	Possible cause	Solutions
1	Master Relay Error	1. Live wire grounding on grid side 2. Grid voltage too low 3. Inverter relay circuit fault	1. Measure the voltage between the ground wire and the neutral wire to see if it exceeds 10V. 2. Measure if the grid voltage is too low.
2	Master EEPROM Error	Inverter internal memory fault	1. Disconnect AC and DC switches for 5 minutes, then restart the inverter. 2. Check if there is a firmware upgrade and whether the correct firmware version is selected.
3	Master Temperature High Error	Inverter temperature too high	1. Check if the inverter's heat dissipation path is blocked. 2. Check if the inverter is installed in direct sunlight. 3. Check if the installation environment has good ventilation.
4	Master Temperature Low Error	Inverter temperature too low	Check if the ambient temperature at the inverter installation location is too low
5	Master Lost Communication M<->S	Internal communication loss in inverter	Disconnect AC and DC switches for 5 minutes, then restart the inverter.
6	Master GFCI Device Error	Inverter leakage current detection device failure	
7	Master DCI Device Error	Inverter DC component detection device failure	
8	Master Current Sensor Error	Inverter current detection device failure	1. Disconnect AC and DC switches for 5 minutes, then restart the inverter. 2. Check if the string MC4 connectors have reversed polarity.
9	Master Phase1 Voltage High	Grid voltage exceeds the safety permissible range of the inverter	1. Check if the grid voltage is too high. 2. Check if the inverter AC output cable connections are secure and if the grid-tie cable is too thin. 3. Check if the inverter grid compliance specifications are selected correctly.

10	Master Phase1 Voltage Low	Grid voltage below the safety permissible range of the inverter	<ol style="list-style-type: none"> 1. Check if the grid voltage is too low. 2. Check if the inverter AC output cable connections are secure. 3. Check if the inverter grid compliance specifications are selected correctly.
11	Master Phase2 Voltage High	Grid voltage exceeds the safety permissible range of the inverter	<ol style="list-style-type: none"> 1. Check if the grid voltage is too high. 2. Check if the inverter AC output cable connections are secure and if the grid-tie cable is too thin. 3. Check if the inverter grid compliance specifications are selected correctly.
12	Master Phase2 Voltage Low	Grid voltage below the safety permissible range of the inverter	<ol style="list-style-type: none"> 1. Check if the grid voltage is too low. 2. Check if the inverter AC output cable connections are secure. 3. Check if the inverter grid compliance specifications are selected correctly.
13	Master Phase3 Voltage High	Grid voltage exceeds the safety permissible range of the inverter	<ol style="list-style-type: none"> 1. Check if the grid voltage is too high. 2. Check if the inverter AC output cable connections are secure and if the grid-tie cable is too thin. 3. Check if the inverter grid compliance specifications are selected correctly.
14	Master Phase3 Voltage Low	Grid voltage below the safety permissible range of the inverter	<ol style="list-style-type: none"> 1. Check if the grid voltage is too low. 2. Check if the inverter AC output cable connections are secure. 3. Check if the inverter grid compliance specifications are selected correctly.
15	Master Voltage 10Min High	Grid voltage exceeds the safety permissible range of the inverter	<ol style="list-style-type: none"> 1. Check if the grid voltage is too high. 2. Check if the inverter AC output cable connections are secure and if the grid-tie cable is too thin. 3. Check if the inverter grid compliance specifications are selected correctly.
16	Master OffGrid Voltage Low	Excessive load power on off-grid port, low battery SOC, or high/low battery temperature causing derated battery output	<ol style="list-style-type: none"> 1. Reduce the load connected to the off-grid port. 2. Check if the battery charge is too low. 3. Check if the battery ambient temperature is too high or too low.
17	Master Output_Shorter	External wiring short circuit at back-up port	Correct the external wiring of the back-up port.
18	Master Grid Frequency High	Grid frequency exceeds local grid upper limit	<ol style="list-style-type: none"> 1. Check if the inverter grid compliance specifications are selected correctly. 2. Disconnect AC and DC switches for 5 minutes, then restart the inverter.
19	Master Grid Frequency Low	Grid frequency below local grid lower limit	

20	BATInputMode Error	Batteries not connected in parallel as required	<ol style="list-style-type: none"> 1. Check if the configured battery input mode is correct 2. If the battery input is confirmed to be in parallel mode, check if all battery connections are secure.
21	Master Phase1 DCV Error	DC component of AC output exceeds limit	Disconnect AC and DC switches for 5 minutes, then restart the inverter.
22	Master Phase2 DCV Error	DC component of AC output exceeds limit	
23	Master Phase3 DCV Error	DC component of AC output exceeds limit	
24	Master No Grid Error	Inverter cannot detect grid voltage	<ol style="list-style-type: none"> 1. Confirm whether the grid is powered off, check if the grid-tie box switch has tripped, and ensure the inverter AC cables are securely connected. 2. If there is no power outage, disconnection, or loose connections after the above checks, close the AC switch and reconnect to the grid.
25	DC ReverseConnect Error	Reverse polarity connection at PV or battery ports	Check the DC port wiring.
26	Parallel machine CAN Com Error	Parallel system CAN communication failure	Check the parallel system CAN communication wiring.
27	Master GFCI Error	System ground leakage current fault detected	<ol style="list-style-type: none"> 1. Disconnect AC and DC switches, check if the AC output ground wire is secure and if the AC wiring is correct. 2. Check if the AC/DC cables are damaged or soaked, and if the panels are soaked.
28	Master Phase1 DCI Error	DC component of AC output exceeds limit	Disconnect AC and DC switches for 5 minutes, then restart the inverter.
29	Master Phase2 DCI Error	DC component of AC output exceeds limit	
30	Master Phase3 DCI Error	DC component of AC output exceeds limit	
31	Master ISO Error	PV string insulation resistance to ground below set value	<ol style="list-style-type: none"> 1. Disconnect AC and DC switches, check if the AC output ground wire is secure and if the AC wiring is correct. 2. Check if the AC/DC cables are damaged or soaked, and if the panels are soaked.

32	Master Bus Voltage Balance Error	Bus voltage imbalance	Disconnect AC and DC switches for 5 minutes, then restart the inverter.
33	Master Bus Voltage High	DC input voltage exceeds the allowable input limit of the inverter	<ol style="list-style-type: none"> 1. Check the number of panels in each string, calculate whether the open-circuit voltage of the string exceeds the maximum input voltage of the inverter. 2. If the above checks confirm no issues, close the AC switch and restart the inverter.
34	Master Bus Voltage Low	Bus voltage of the inverter is too low	Disconnect AC and DC switches for 5 minutes, then restart the inverter.
35	Master Grid Phase Error	Abnormal phase sequence between three-phase power	Measure the voltage between each phase of the three-phase power to check if it is normal.
36	Master PV Voltage High Error	DC input voltage of the inverter is too high	<ol style="list-style-type: none"> 1. Check the number of panels in each string, calculate whether the open-circuit voltage of the string exceeds the maximum input voltage of the inverter. 2. If the above checks confirm no issues, close the AC switch and restart the inverter.
37	Master Islanding Error	Grid loss causing islanding effect	<ol style="list-style-type: none"> 1. Confirm whether the grid is powered off, check if the grid-tie box switch has tripped, and ensure the inverter AC cables are securely connected. 2. If there is no power outage, disconnection, or loose connections after the above checks, close the AC switch and reconnect to the grid.
38	Master HW Bus Voltage High	DC input voltage exceeds the allowable input limit of the inverter	<ol style="list-style-type: none"> 1. Check the number of panels in each string, calculate whether the open-circuit voltage of the string exceeds the maximum input voltage of the inverter. 2. If the above checks confirm no issues, close the AC switch and restart the inverter.
39	Master HW PV Current High	<ol style="list-style-type: none"> 1. PV string positive and negative poles are reversed 2. Inverter internal damage 	<ol style="list-style-type: none"> 1. Check whether the positive and negative poles of the string are reversed. 2. If the above checks confirm no issues, close the AC switch and restart the inverter.
41	Master HW Inv Current High	Grid-side output current exceeds the inverter limit	<ol style="list-style-type: none"> 1. Disconnect AC and DC switches, check if the AC cables are securely connected. 2. If the above checks confirm no issues, close the AC switch and restart the inverter.
44	Master Grid NE Voltage Error	Live wire grounding on grid side	<ol style="list-style-type: none"> 1. Measure the voltage between the ground wire and the neutral wire. 2. If it exceeds 10V, it indicates a live wire grounding issue.

45	Master Fan1 Error	Fan blade stuck or damaged	<ol style="list-style-type: none"> 1. Check if the external fan (if present) is operating normally. 2. If the fan is operating normally but the fault persists, disconnect AC and DC switches for 5 minutes and restart the inverter.
46	Master Fan2 Error	Fan blade stuck or damaged	
47	Master Fan3 Error	Fan blade stuck or damaged	
48	Master Fan4 Error	Fan blade stuck or damaged	
49	Lost Communication between DSP and PowerMeter	Communication abnormality between inverter and meter	<ol style="list-style-type: none"> 1. Confirm whether the meter is working properly. 2. Check if the communication wiring between the inverter and the meter is secure. 3. Verify that the communication parameter settings between the inverter and the meter are correct, including address, baud rate, etc.
50	Lost Communication between M<->S	Internal communication loss in inverter	Disconnect AC and DC switches for 5 minutes, then restart the inverter.
51	Lost Communication between inverter and Grid Meter	Communication abnormality between inverter and grid meter	<ol style="list-style-type: none"> 1. Confirm whether the meter is working properly. 2. Check if the communication wiring between the inverter and the meter is secure. 3. Verify that the communication parameter settings between the inverter and the meter are correct, including address, baud rate, etc.
52	HMI EEPROM Error	Inverter internal memory fault	<ol style="list-style-type: none"> 1. Disconnect AC and DC switches for 5 minutes, then restart the inverter. 2. Check if there is a firmware upgrade and whether the correct firmware version is selected.
53	HMI RTC Error	RTC fault	Contact the installer.
54	BMS Device Error	Battery abnormality	
55	BMS Lost.Conn Warn	BMS not started properly	<ol style="list-style-type: none"> 1. Check if the BMS button is turned on. 2. Check if the BMS button is lit.
59	Lost Communication between inverter and PV Meter	Communication loss between inverter and PV meter	<ol style="list-style-type: none"> 1. Confirm whether the meter is working properly. 2. Check if the communication wiring between the inverter and the meter is secure. 3. Verify that the communication parameter settings between the inverter and the meter are correct, including address, baud rate, etc.
60	EV_Lost.Conn Warn	Communication loss between charging pile and inverter	Contact the installer.
61	Slave Phase1 Voltage High	Grid voltage exceeds the safety permissible range of the inverter	<ol style="list-style-type: none"> 1. Check if the grid voltage is too high. 2. Check if the inverter AC output cable connections are secure and if the grid-tie cable is too thin. 3. Check if the inverter grid compliance specifications are selected correctly.
62	Slave Phase1 Voltage Low	Grid voltage below the safety permissible range of the inverter	<ol style="list-style-type: none"> 1. Check if the grid voltage is too low. 2. Check if the inverter AC output cable connections are secure. 3. Check if the inverter grid compliance specifications are selected correctly.

63	Slave Phase2 Voltage High	Grid voltage exceeds the safety permissible range of the inverter	<ol style="list-style-type: none"> 1. Check if the grid voltage is too high. 2. Check if the inverter AC output cable connections are secure and if the grid-tie cable is too thin. 3. Check if the inverter grid compliance specifications are selected correctly.
64	Slave Phase2 Voltage Low	Grid voltage below the safety permissible range of the inverter	<ol style="list-style-type: none"> 1. Check if the grid voltage is too low. 2. Check if the inverter AC output cable connections are secure. 3. Check if the inverter grid compliance specifications are selected correctly.
65	Slave Phase3 Voltage High	Grid voltage exceeds the safety permissible range of the inverter	<ol style="list-style-type: none"> 1. Check if the grid voltage is too high. 2. Check if the inverter AC output cable connections are secure and if the grid-tie cable is too thin. 3. Check if the inverter grid compliance specifications are selected correctly.
66	Slave Phase3 Voltage Low	Grid voltage below the safety permissible range of the inverter	<ol style="list-style-type: none"> 1. Check if the grid voltage is too low. 2. Check if the inverter AC output cable connections are secure. 3. Check if the inverter grid compliance specifications are selected correctly.
67	Slave Frequency High	Grid frequency exceeds local grid upper limit	<ol style="list-style-type: none"> 1. Check if the inverter grid compliance specifications are selected correctly.
68	Slave Frequency Low	Grid frequency below local grid lower limit	<ol style="list-style-type: none"> 2. Disconnect AC and DC switches for 5 minutes, then restart the inverter.
69	DCDC_Lost.Conn Warn	Communication loss between DCDC device and inverter	Contact the installer.
70	DCDC_Device Error	DCDC device fault	
71	Parall CAN Lost Com. Err	Number of online slave units read by parallel host does not match configured parallel number	<ol style="list-style-type: none"> 1. Check if the slave ID settings are correct. 2. Check if the parallel CAN communication cable is properly connected.
72	LCD Lost comm.Err	Inverter does not receive communication data from LCD	Check if the communication cable between the LCD and the inverter is properly connected.
73	Slave No Grid Error	Inverter cannot detect grid voltage	<ol style="list-style-type: none"> 1. Confirm whether the grid is powered off, check if the grid-tie box switch has tripped and ensure the inverter AC cables are securely connected. 2. If there is no power outage, disconnection, or loose connections after the above checks, close the AC switch and reconnect to the grid.
76	Slave PV Voltage High	DC input voltage of the inverter is too high	<ol style="list-style-type: none"> 1. Check the number of panels in each string, calculate whether the open-circuit voltage of the string exceeds the maximum input voltage of the inverter. 2. If the above checks confirm no issues, close the AC switch and restart the inverter.
78	Grid Power Emergency Disconnect	Grid AC relay disconnects based on external device command	Contact the installer.
81	Lost Communication D<->C	Internal communication loss in inverter	Disconnect AC and DC switches for 5 minutes, then restart the inverter.

83	Master Arc Device Error	Arc fault device failure	Contact the installer or SAJ Electric service hotline.
84	Master PV Mode Error	PV mode selection error	<ol style="list-style-type: none"> 1. Check whether the inverter string mode is set correctly 2. If the fault persists after resolving the above, contact the installer or SAJ Electric service hotline.
85	Authority expires	Authorization expired	Contact the installer or SAJ Electric service hotline.
86	DRMO Error	DRMO fault	Contact the installer or SAJ Electric service hotline.
87	Master Arc Error	DC arcing caused by short circuit or poor terminal contact	<ol style="list-style-type: none"> 1. Check if all terminals are properly connected and whether the PV positive/negative insulation to ground is normal. 2. If the above checks confirm no issues, close the AC switch and restart the inverter.
88	Master SW PV Current High	<ol style="list-style-type: none"> 1. PV string positive and negative poles are reversed 2. Inverter internal damage 	<ol style="list-style-type: none"> 1. Check whether the positive and negative poles of the string are reversed. 2. If the above checks confirm no issues, close the AC switch and restart the inverter.
89	Master Battery Voltage High	Battery voltage too high	Battery voltage is higher than the maximum voltage value of the inverter.
90	Master Battery Current High	Battery SOC too low or load too heavy, preventing battery output	<ol style="list-style-type: none"> 1. Reduce the back-up load. 2. Charge the battery or stop using the battery. 3. If the battery charge and load are normal but the fault persists, contact the installer or SAJ Electric service hotline.
91	Master Battery Charge Voltage High	Battery voltage too high during charging	<ol style="list-style-type: none"> 1. Do not turn off the battery during charging. 2. Restart the battery and inverter.
92	Master Battery OverLoad	Battery SOC too low or load too heavy, preventing battery output	<ol style="list-style-type: none"> 1. Reduce the back-up load. 2. Charge the battery or stop using the battery. 3. If the battery charge and load are normal but the fault persists, contact the installer or SAJ Electric service hotline.
93	Master Battery SoftConnet TimeOut	Battery pre-charging bus failure	Contact the installer or SAJ Electric service hotline.
94	Master Output OverLoad	Load connected to back-up port exceeds H2 maximum output power	Reduce the load connected to the back-up port.
95	Master Battery Open Circuit Error	Inverter cannot detect battery voltage	<ol style="list-style-type: none"> 1. Check if the battery circuit breaker is turned on. 2. Check if the battery power cable connections are secure.
96	Master Battery Discharge Voltage Low	Voltage too low detected during battery discharge overload	<ol style="list-style-type: none"> 1. Do not turn off the battery during discharge. 2. The battery voltage is too low, system protection.

97	BMS Internal Communication Error	1. Communication abnormality between battery high-voltage box and battery pack 2. The last battery pack not connected with a resistor terminator causing abnormal pack quantity recognition by the high-voltage box	1. Check if the communication cable is abnormal. 2. Check if the last battery pack has a terminator connected.
98	Bat Sequence Error	Battery pack communication abnormality	1. Check if the communication cable wiring is correct. 2. Check if the last battery pack has a terminator connected 3. Check if the communication cable is abnormal.
99	Discharge Over Current Protect	Discharge current exceeds set threshold	Wait for the fault to clear or restart.
100	Charge Over Current Protect	Charge current exceeds set threshold	Wait for the fault to clear or restart.
101	Module Under Voltage Protect	Total voltage below set threshold	Force charge the battery.
102	Module Over Voltage Protect	Total voltage above set threshold	Wait for the fault to clear or restart.
103	Single Cell Under Voltage Protect	Cell voltage below minimum set value	Force charge the battery.
104	Single Cell Over Voltage Protect	Cell voltage above set threshold	Wait for the fault to clear or restart.
105	BMS Hardware Error	1. Cell voltage detection module fault 2. Temperature detection module fault 3. Current detection module fault	If the fault persists after restarting, contact the installer.
106	Charge Cell Under Temperature Protect	Battery charging below 0°C	Wait for the battery temperature to rise until the fault clears.
107	Charge Cell Over Temperature Protect	Battery temperature too high	Wait for the battery temperature to drop until the fault clears.
108	Discharge Cell Under Temperature Protect	Battery temperature too low, relay disconnects to stop discharge	Wait for the battery temperature to rise until the fault clears.
109	Discharge Cell Over Temperature Protect	Battery temperature too high	Wait for the battery temperature to drop until the fault clears.

110	Relay Error	1. Negative or positive relay stuck 2. Negative or positive relay unable to close	If the fault persists after restarting, contact the installer.
111	Pre-charge Error	1. Pre-charge relay damaged 2. Pre-charge resistor open circuit 3. BMS damaged	
112	Insulation Error	Possible leakage current issue in battery pack	Contact the installer.
113	BMS supplier Incompatibility	BMS mismatch between battery pack and high-voltage box	
114	Battery cell supplier Incompatibility	Inconsistent cell manufacturers within battery pack	
115	Battery cell Incompatibility	Inconsistent cell grades within battery pack	
116	Battery pack models or grades are inconsistent	Battery pack model or grade mismatch	
117	Circuit Breaker Is Open	1. Battery circuit breaker not closed 2. Battery circuit breaker auxiliary contact abnormality	Close the battery circuit breaker.
118	Temperature Difference Is Too Wide	Temperature detection module fault	If the fault persists after restarting, contact the installer.
119	Voltage Difference Is Too Wide	Sampling wire loose	
120	Voltage Difference Is Too Wide	Sampling wire loose	
121	BMS Over Temperature Protect	1. Ambient temperature too high 2. Battery overload	1. Check if the battery ambient temperature is too high. 2. If the temperature is normal, let the battery rest for 30 minutes and restart.
122	Short Circuit Protect	Short circuit between battery positive and negative terminals	Check if the battery wiring is correct.
123	Total voltage match failed	Contact technical personnel to troubleshoot the issue	Contact the installer.
124	The system is locked	Contact technical personnel to troubleshoot the issue	
125	FUSE error protection	Contact technical personnel to troubleshoot the issue	

126	Battery Port Voltage Abnormal Protection	Contact technical personnel to troubleshoot the issue	
127	Heating Film Overtemperature Protection	Contact technical personnel to troubleshoot the issue	Contact the installer.
128	Abnormal Temperature Increases	Contact technical personnel to troubleshoot the issue	
162	Gen Start or Stop Error	Check the connection between the generator and the inverter	
289	Relay over temperature	Charging pile internal status abnormal Relay temperature consistently above 115°C causing fault	<ol style="list-style-type: none"> 1. Reduce current output, stop charging and let it cool down before attempting to charge again. 2. If the fault occurs again, contact the installer.
290	Overload	Contact technical personnel to troubleshoot the issue	Contact the installer.
291	AC over voltage	Grid voltage at pile input exceeds 276V, or does not recover below 265V after overvoltage	<ol style="list-style-type: none"> 1. Normally, the charging pile fault will clear automatically after the grid returns to normal. If the fault recurs: measure the actual grid voltage. 2. If the grid voltage is indeed higher than 265V, contact the local power company for resolution.
292	AC under voltage	Grid voltage at pile input below 184V, or does not recover above 196V after undervoltage	<ol style="list-style-type: none"> 1. Normally, the charging pile fault will clear automatically after the grid returns to normal. If the fault recurs: measure the actual grid voltage. 2. If the grid voltage is indeed lower than 196V, contact the local power company for resolution. 3. Check if the charging pile AC wiring is tight.
293	AC over current	Output current value exceeds 18A	<ol style="list-style-type: none"> 1. Stop charging, unplug the charging gun, wait for the charging pile fault status to clear, then try charging again. 2. If the fault recurs, contact the vehicle manufacturer's after-sales service. 3. Stop charging, unplug the charging gun.
294	AC over frequency	Mains AC frequency exceeds 63Hz, or does not recover below 61Hz after over frequency	<ol style="list-style-type: none"> 1. Normally, the charging pile fault will clear automatically after the grid returns to normal. If the fault recurs: measure the actual grid frequency. 2. If the grid frequency is indeed higher than 61Hz, contact the local power company for resolution.
295	AC under frequency	Mains AC frequency below 47Hz, or does not recover above 49Hz after under frequency	<ol style="list-style-type: none"> 1. Normally, the charging pile fault will clear automatically after the grid returns to normal. If the fault recurs: measure the actual grid frequency. 2. If the grid frequency is indeed lower than 49Hz, contact the local power company for resolution.

296	DC residual current exception A	Save one point every 20ms, fault reported if 3 consecutive points exceed 50mA (60~80ms) DC leakage current greater than 6mA (reaction time 10s)	<ol style="list-style-type: none"> 1. Stop charging, unplug the charging gun, wait for the charging pile fault status to clear, then try charging again. 2. If the fault recurs, contact the vehicle manufacturer's after-sales service. 3. Stop charging, unplug the charging gun. 4. If the charging pile remains in a fault state, contact the installer.
297	Emergency Stop	User mistakenly pressed emergency stop button	Reset the emergency stop button.
298	Under temperature	Contact technical personnel to troubleshoot the issue	Contact the installer.
299	AC residual current	RCD residual current device circuit abnormal (During pile self-test, leakage current not within 5~20mA for 10 consecutive seconds)	<ol style="list-style-type: none"> 1. Restart the device after power off and try charging again. 2. If the fault occurs again, contact the installer.
300	Input terminal over temperature	Loose input terminal wiring, poor contact Selected cable ampacity does not meet requirements	Check if the charging pile AC wiring is tight and if the cable cross-section meets requirements.
301	Bluetooth fault	Contact technical personnel to troubleshoot the issue	Contact the installer.
302	DC residual current exception B	Save one point every 60ms, fault reported if 3 consecutive points exceed 36mA (180~240ms) DC leakage current greater than 6mA (reaction time 10s)	<ol style="list-style-type: none"> 1. Stop charging, unplug the charging gun, wait for the charging pile fault status to clear, then try charging again. 2. If the fault recurs, contact the vehicle manufacturer's after-sales service. 3. Stop charging, unplug the charging gun. 4. If the charging pile remains in a fault state, contact the installer.
303	Relay exception	After plugging in gun, relay detected stuck 3 times consecutively and unable to disconnect (auto-closing)	<ol style="list-style-type: none"> 1. Restart the device after power off and try charging again. 2. If the fault occurs again, contact the installer.
304	Grounding error	Voltage between GND and N greater than 36V alarm, does not affect charging	<ol style="list-style-type: none"> 1. Check the voltage between the N wire and PE wire at the charging pile input. 2. If the voltage is greater than 36V, check if the equipment ground wire is loose and ensure good grounding.
305	Phase twisted	Input L and N reversed	Check if the L and N wire sequence of the charging pile input cable is correct.

306	RCD circuit exception	RCD residual current device circuit abnormal (During pile self-test, leakage current not within 5~20mA for 10 consecutive seconds)	<ol style="list-style-type: none"> 1. Restart the device after power off and try charging again. 2. If the fault occurs, contact the installer.
307	RS485 Com time out	<ol style="list-style-type: none"> 1. Wiring issue 2. Backend has update, unable to communicate 	<ol style="list-style-type: none"> 1. Check wiring issues, open the cover and reconnect. 2. If the problem cannot be resolved, contact the installer.
308	Electricity exception	Contact technical personnel to troubleshoot the issue	Contact the installer.
311	Meter fault	Contact technical personnel to troubleshoot the issue	
312	cp exception, cp lower than 2V	CP voltage below 2V	<ol style="list-style-type: none"> 1. Restart the device after power off and try charging again. 2. If the fault occurs again, contact the installer.
318	Connector lock exception	<ol style="list-style-type: none"> 1. Foreign objects may block gun lock 2. Gun not plugged in properly 	<ol style="list-style-type: none"> 3. Open the cover for inspection, remove any foreign objects. 4. Plug the gun in properly.
319	Connector current exception	Gun cable specification issue	Contact the installer.
320	DC residual current exception C	Contact technical personnel to troubleshoot the issue	

10.

PRODUCT SPECIFICATIONS



Model	H2-5K-LS2	H2-6K-LS2	H2-7.6K-LS2	H2-8K-LS2	H2-10K-LS2	H2-12K-LS2
PV String Input						
Max. PV access power [Wp] @STC	10000	12000	15200	16000	20000	24000
Max. PV input power [W]	8000	9600	12200	12800	16000	19200
Max. DC voltage [V]	500					
MPPT voltage range [V]	90-480					
Rated DC voltage [V]	360					
Start-up voltage [V]	80					
Max. DC input current [A]	20/20		40/40			
Max. DC short current [A]	25/25		50/50			
No. of MPPT	2					
Battery						
Battery type	Lead-acid or LiFePO4					
Voltage range [V]	40-60					
Max. charging / discharging current [A]	100	120	190	190	240	240
AC Output [On-grid]						
Rated AC power [W]	5000	6000	7600	8000	10000	12000
Max. apparent power [VA]	5500	6600	8360	8800	10000	12000
Rated output current [A] @230 V	21.8	26.0	33.0	34.8	43.5	52.2
Max. output current [A]	25.0	30.0	38.0	40.0	45.5	54.6
Rated output voltage / range [V]	L+N+PE, 220, 230, 240 V /180-280 V					
Rated output frequency / range [Hz]	50 Hz: 45-55 Hz 60 Hz: 55-65 Hz					

Model	H2-5K-LS2	H2-6K-LS2	H2-7.6K-LS2	H2-8K-LS2	H2-10K-LS2	H2-12K-LS2
Power factor [cosφ]	0.8 leading-0.8 lagging					
Total harmonic distortion [THDi]	< 3%					
AC Output [Back-up]						
Max. output power [VA]	5000	6000	7600	8000	10000	12000
Max. output current [A]	25.0	30.0	38.0	40.0	45.5	54.6
Peak output apparent power [VA]	10000, 10s	12000, 10s	15200, 10s	16000, 10s	20000, 10s	24000, 10s
Rated output voltage / range [V]	L+N+PE, 220, 230, 240 / 180-280					
Rated output frequency / range [Hz]	50 Hz: 45-55 Hz 60 Hz: 55-65 Hz					
Output THDv (@ Liner Load)	< 3%					
AC Input [On-grid]						
Rated AC input voltage / range [V]	L+N+PE, 220, 230, 240 / 180-280					
Rated input frequency [Hz]	50, 60					
Bypass Current [A] @230 V	63					
Efficiency						
Max. Efficiency	97.6%					
Euro Efficiency	97.0%					
Protection						
Battery input reverse polarity protection	Integrated					
Overload protection	Integrated					
AC short circuit current protection	Integrated					
DC surge protection	Integrated					
AC surge protection	Integrated					

Model	H2-5K-LS2	H2-6K-LS2	H2-7.6K-LS2	H2-8K-LS2	H2-10K-LS2	H2-12K-LS2
Anti-islanding protection	Integrated					
AFCI protection	Optional					
RSD protection	Optional					
Interface						
PV connection	MC4					
AC connection	Terminal block					
Battery connection	Terminal block					
Display	LCD + LED + App					
Communication	Wi-Fi/ Ethernet/ 4G (optional)					
General Parameters						
Topology	Non-isolated					
Operating temperature range	-40°C to +60°C / -40°F to +140°F (50°C to 60°C with derating)					
Cooling method	Intelligent fan cooling					
Ambient humidity	0%–100% No condensation					
Altitude [m]	4000m (>3000m power derating)					
Noise [dBA]	< 50					
Ingress protection rating	IP65					
Mounting	Wall mounting					
Dimension [H x W x D] [mm]	588 x 378 x 239 mm (23.15 x 14.88 x 9.41 inch)					
Weight [kg]	29					
Warranty [year]	5-10					
Standard	EN 62109-1/2, EN 61000-6-1/2/3/4, IEC 62116, IEC 61727, IEC62183, PEA&MEA, NBR 16149, NBR 16150, PORTARIA N° 140,515, NRS097					

11.

**ADVANCED
APPLICATION**



12.

APPENDIX



12.1. Recycling and disposal

This device should not be disposed of as residential waste.

An inverter that has reached the end of its operation life is not required to be returned to your dealer; instead, it must be disposed of by an approved collection and recycling facility in your area.

12.2. Warranty

Check the product warranty conditions and terms on the SAJ website: <https://www.saj-electric.com/>

12.3. Contacting support

Online technical support

Go to <https://www.saj-electric.com/services-support-technical> to check FAQs or send your message or product enquiry.

Call for assistance

For SAJ support telephone numbers, see <https://www.saj-electric.com/locations> for your region support details.

Head Quarter

Guangzhou Sanjing Electric Co., Ltd.

Address: SAJ Innovation Park, No.9, Lizhishan Road, Guangzhou Science City, Guangdong, P.R.China.

Tel: +86 20 6660 8588

E-mail: service@saj-electric.com

Website: <https://www.saj-electric.com/>

12.4. Trademark

SAJ is the trademark of SanJing.



GUANGZHOU SANJING ELECTRIC CO., LTD

Tel: 86-20-66608588 **Fax:** 86-20-66608589 **Web:** www.saj-electric.com
Add: SAJ Innovation Park, No.9, Lizhishan Road, Science City, Guangzhou High-tech Zone, Guangdong, P.R.China

V0.1