

EK90 series

All-in-One Energy Storage System

EK90 HS5-(8K-20K)-T3-X

Quick Installation Guide

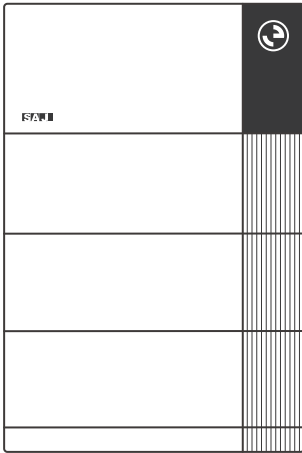

About this document

This quick installation guide provides the installation and electrical connection instructions of the SAJ product.

Scan the following QR code to obtain the latest eManuals:

Scan for eManuals



Note:

Illustrations in this document show only essential details and may differ from the actual product.



NOTICE

- This document may be updated without notice and is for guidance only. No warranties are implied.
- Read the product *User Manual* before installation for product details and safety instructions.
- Only qualified electrical professionals familiar with grid-connected PV systems and local standards may perform installation or servicing.
- Check the *Packing List* before installation; report any missing or damaged items to your dealer.
- Damage from improper installation or operation not following this document or the *User Manual* is not covered by warranty.











WARNING

Risk of High Voltage and Electric Shock

- This device is directly connected to public grid.
- Before operation, ensure the inverter is completely disconnected from all the power sources.
- During operation, wear appropriate personal protective equipment and use insulated tools.
- Failure to follow these instructions will result in serious injury or death.

Safety symbols

Symbol	Description	Symbol	Description
	Danger: Electrical shock hazard		Caution: No disposal in residential waste
	Danger: Hot surface Do not touch metal plate housing during operating.		CE Mark
	Danger: Do not open the cabinet door until 5 minutes after disconnecting all power sources.		RoHS compliant mark
	Warning: No open flames		Caution: Check the user manual before service

Contents

- 1. Installation..... 2**
 - 1.1. Installation preparation..... 2
 - 1.1.1. Environment requirements..... 2
 - 1.1.2. Plan the installation site..... 3
 - 1.1.3. Installation tools..... 4
 - 1.2. Packing list..... 5
 - 1.3. Dimension..... 8
 - 1.4. Ground mounting..... 9
 - 1.5. Wall mounting..... 15

- 2. Electrical connection..... 17**
 - 2.1. Electrical connection diagram..... 17
 - 2.1.1. Inverter ports and switches..... 17
 - 2.1.2. Australia and New Zealand..... 19
 - 2.2. Prepare the cables..... 22
 - 2.3. Connect the grounding cable..... 24
 - 2.4. Connect the AC power cables..... 25
 - 2.5. Connect the DC power cables..... 27
 - 2.6. Connect the communication cables to COM port..... 29
 - 2.7. Connect the communication module..... 32
 - 2.8. Connect the LAN and DRMS cables..... 33
 - 2.9. Connect the antenna..... 34
 - 2.10. Install the inverter cover..... 34

- 3. Start up the system..... 35**

- 4. LED on the inverter..... 36**

- 5. Shut down the system..... 38**

1. Installation

1.1. Installation preparation

1.1.1. Environment requirements

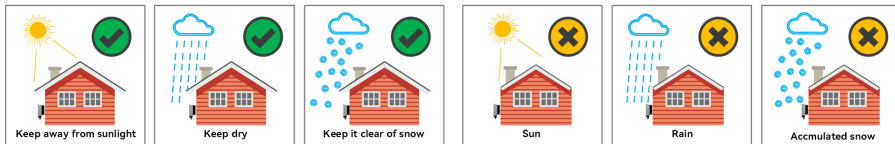

- Do not expose the device to direct solar irradiation as this could cause power derating due to overheating.
- The installation environment must be free of inflammable or explosive materials.
- The device must be installed in a place away from any heat source.
- Do not install the device at a place where the temperature changes extremely.
- Keep the device away from children.
- Do not install the device in the bedroom, toilet, or bathroom.
- When installing the device at the garage, keep it away from the driveway.
- Keep the device from water sources such as taps, sewer pipes and sprinklers to prevent water seepage.
- Ensure the inverter is installed in a well-observed area where the LED display panel can be easily read for real-time status checks.

1.1.2. Plan the installation site

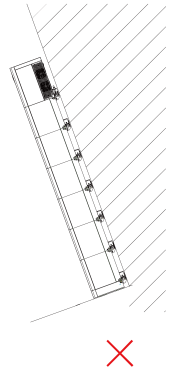
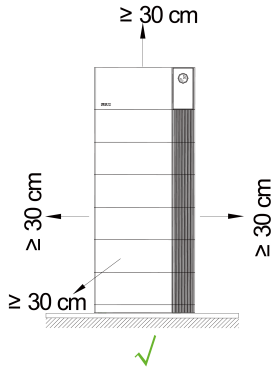
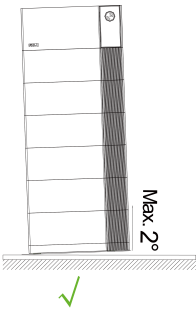
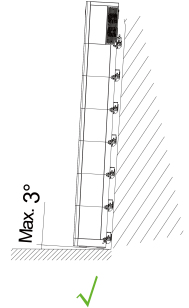
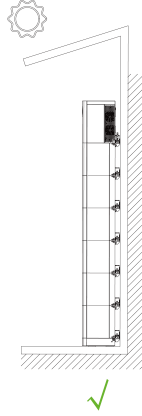
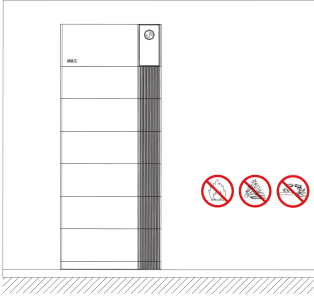

1.1.3. Installation tools

Installation tools include but are not limited to the following recommended ones. Use other auxiliary tools on site if necessary.

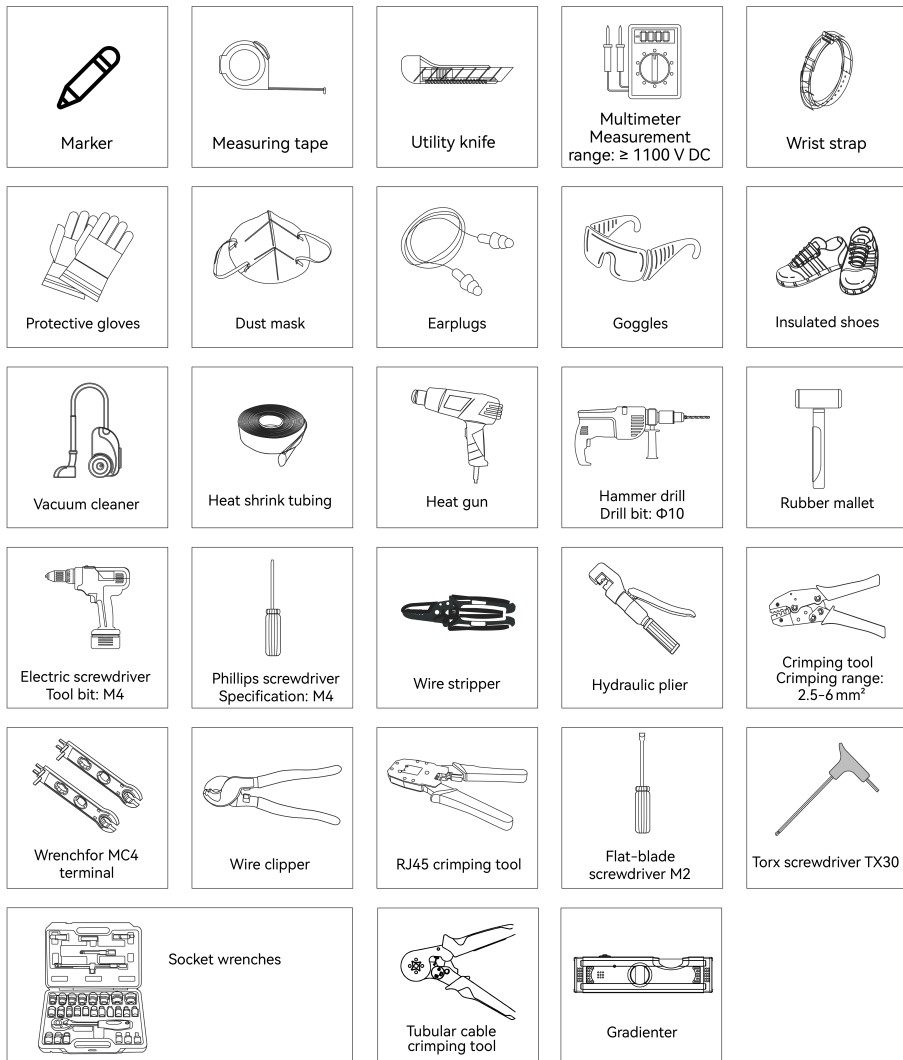
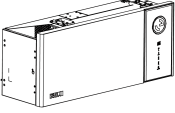

Figure 1.1. Suggested installation tools

1.2. Packing list

Inverter

A



B



C



D



E1



E2



F

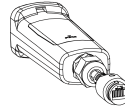

G



Accessory package



H



I

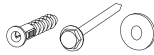

J



K



L



M



N



O



P



Q

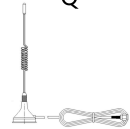

Number	Quantity	Designation
A	1	Inverter
B	1	Protective cover of inverter
C	1	AC protective cover
D	1	PV protective cover
E1	1	Meter
E2	3	Current transformer (CT)
F	1	Communication module
G	1	Documentation

Number	Quantity	Designation
H	1	Anti-theft bracket
I	1	Bolts and gaskets for anti-theft bracket
J	1	Hand-tighten screw
K	15	AC cable terminal
L	4	PV connector
M	1	20-pin connector
N	3	M6*16 screw
O	6	M4*10 screw
P	1	Grounding plate
Q	1	Antenna

Battery pack

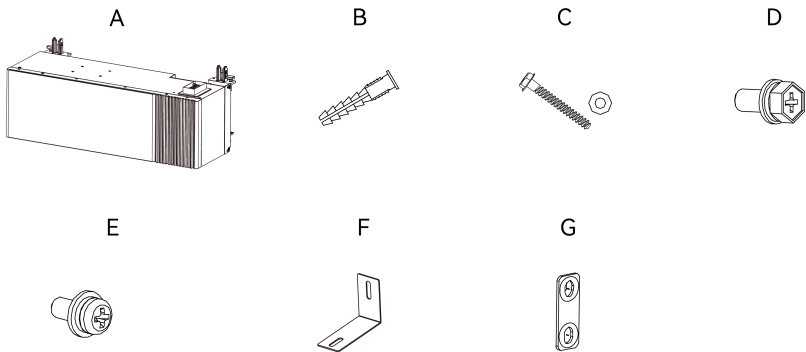

Number	Quantity	Designation
A	1	Battery pack
B	2	M6*80 expansion bolt
C	2	ST6*50 screw and gasket set
D	4	M6*16 screw
E	2	M4*10 screw
F	2	Locking bracket
G	1	Grounding plate

Battery base

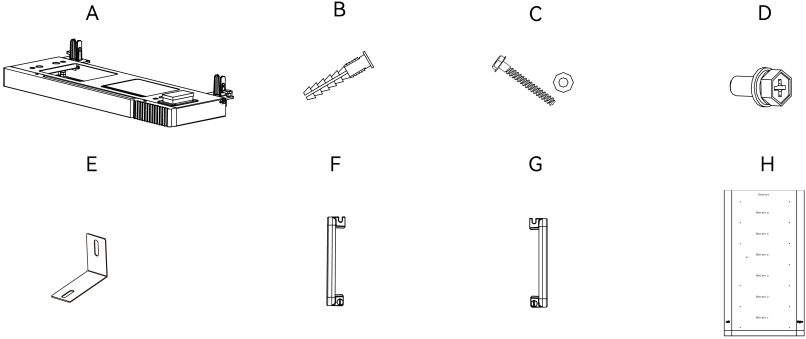

Number	Quantity	Designation
A	1	Battery base
B	2	M6*80 expansion bolt
C	2	ST6*50 screw and gasket set
D	2	M6*16 screw
E	2	Locking bracket
F	1	Left handle
G	1	Right handle
H	1	Positioning cardboard

Wall bracket

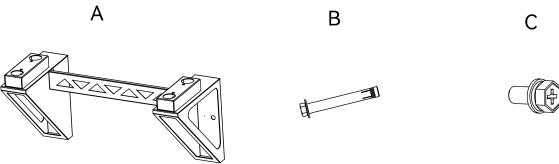

Number	Quantity	Designation
A	1	wall bracket
B	6	M12*100 expansion bolt
C	2	M6*16 screw

1.3. Dimension

Use one stack with six battery modules as an example:

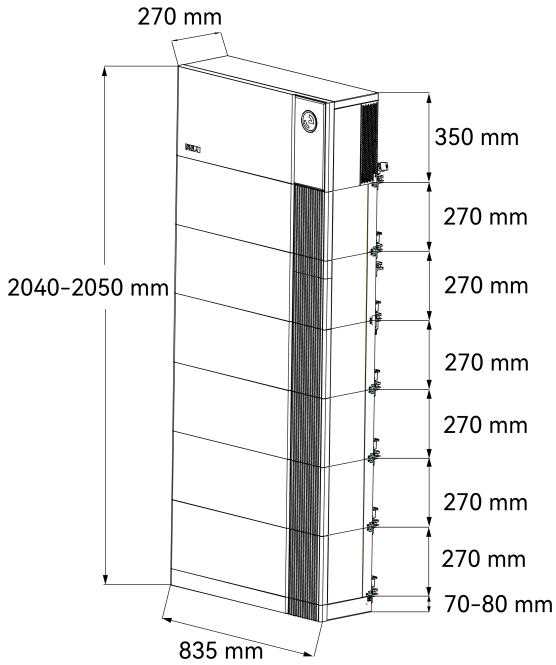
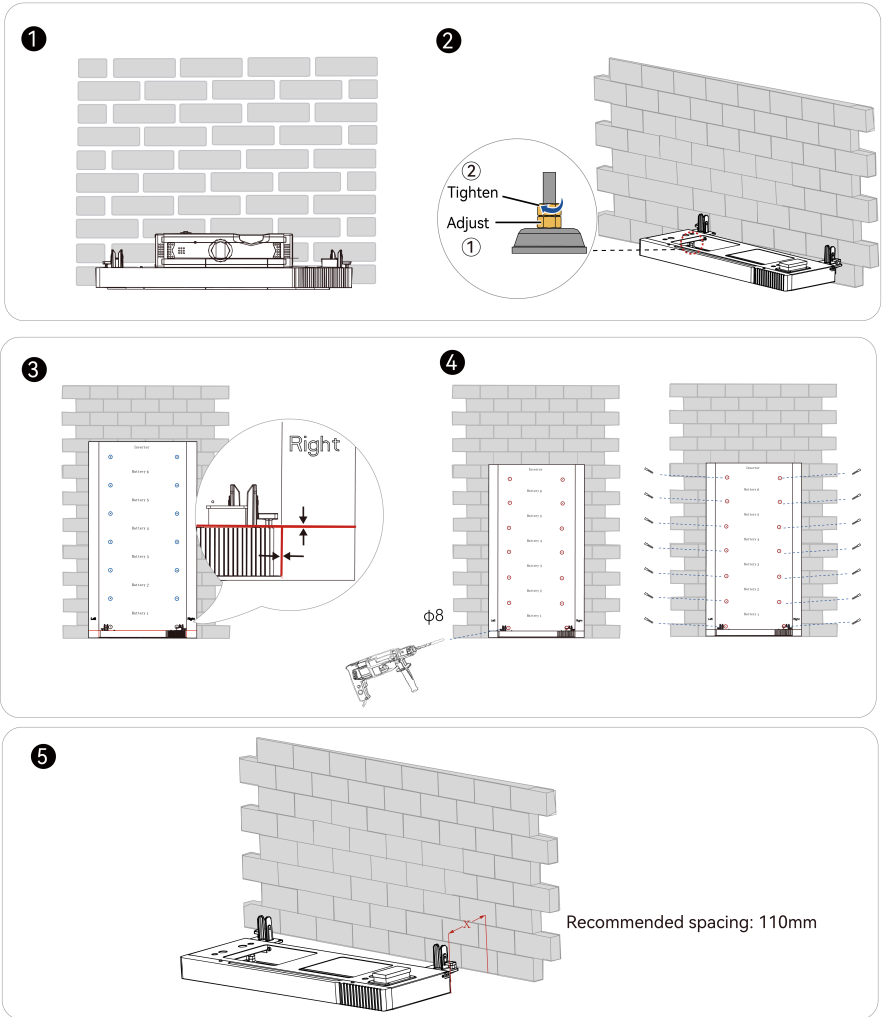
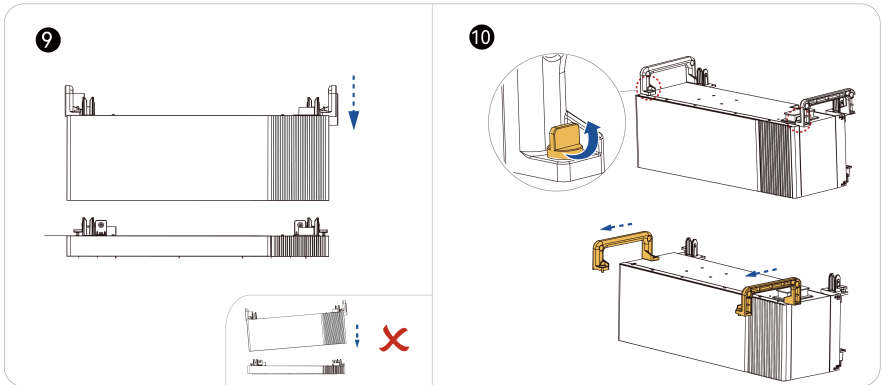
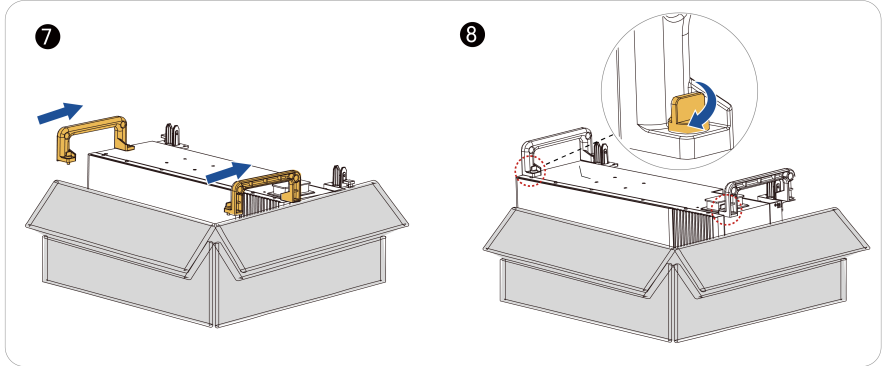
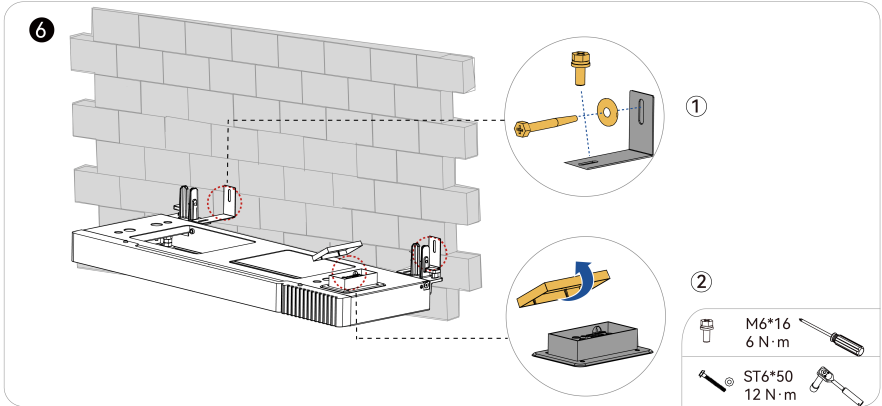

Figure 1.2. Dimensions

1.4. Ground mounting

Note: For ground mounting, a maximum of 6 batteries is supported.





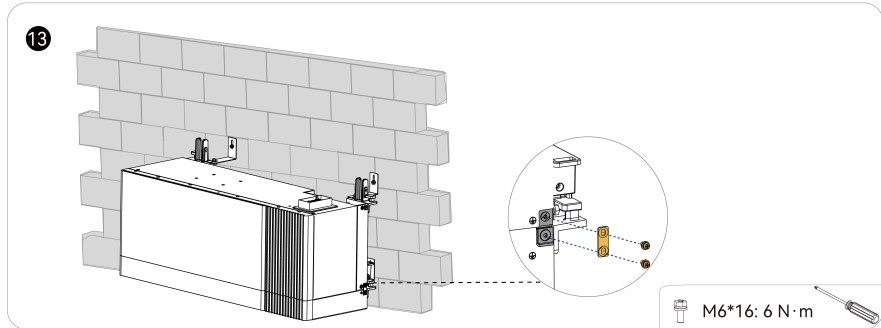
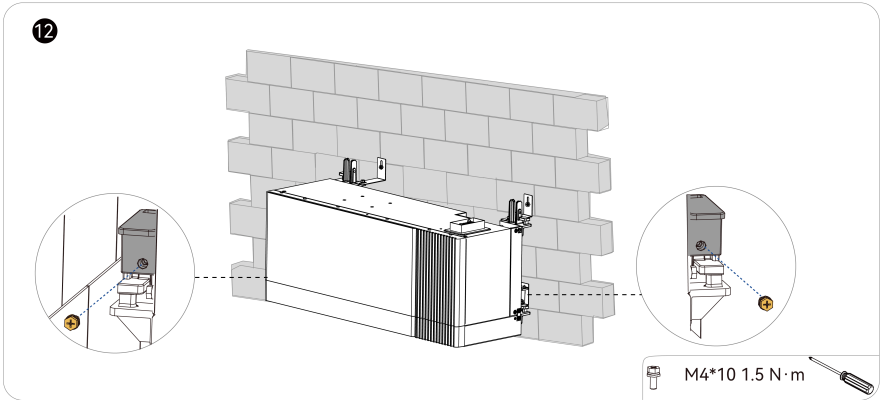
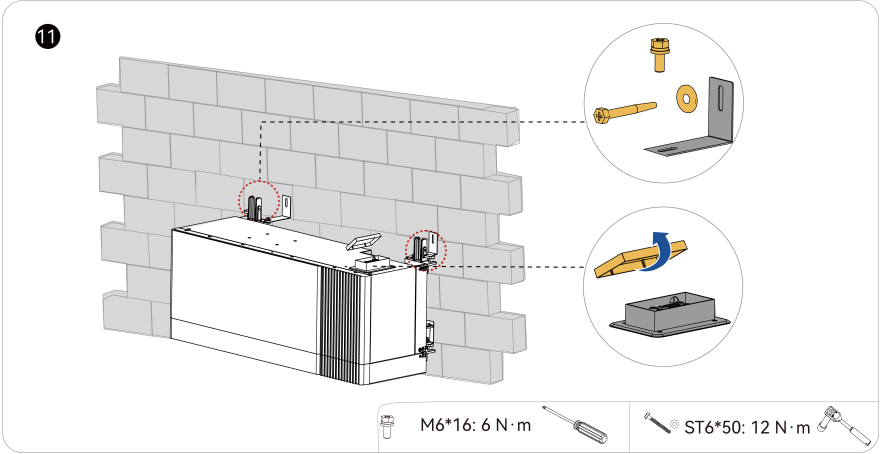

14

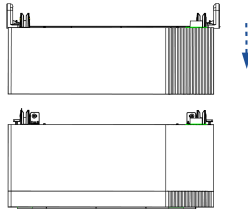

15

Install more batteries by taking the same steps as the first one.

16

≥4 batteries: recommend using a lifting device.

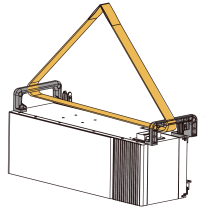

17

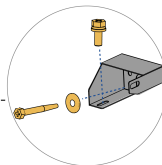
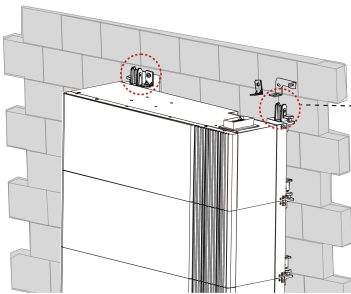

With lock

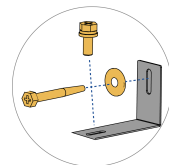

Without lock

M6*16: 6 N·m

ST6*50: 12 N·m

18

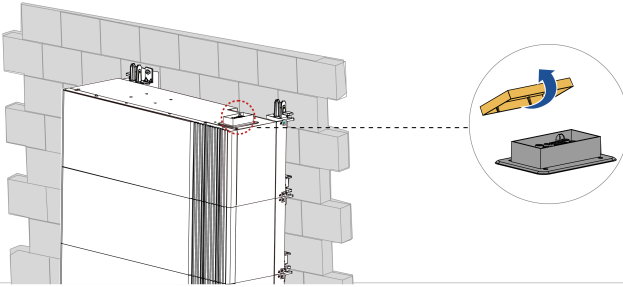

19

≥4 batteries: recommend using a lifting device.

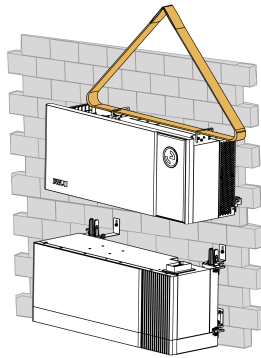



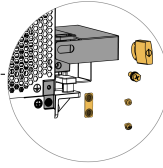
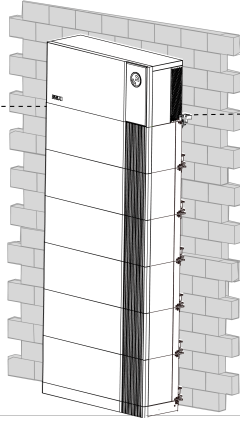

20

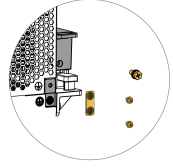

With lock



Without lock

-  M6*16: 6 N·m 
-  M4*10 1.5 N·m 
-  Prepared by the customer

21

X represents the nominal energy of the battery system in kWh.

X = 6 7 9 12 14 15 16
 18 21 24 25 27 28 30
 35 36 40 42 45 50 54



Example

Energy Storage Systems GmbH & Co., Ltd. **SAJ**

All-in-one Energy Storage System

Model:

Max. Power Output	3000 W
Max. Power Input	3000 W
Max. Charge Current	10 A (12 V)
Max. Discharge Current	10 A (12 V)
Max. Charge Voltage	14.6 V (12 V)
Max. Discharge Voltage	12.0 V (12 V)
Max. Charge Current	10 A (12 V)
Max. Discharge Current	10 A (12 V)
Max. Charge Voltage	14.6 V (12 V)
Max. Discharge Voltage	12.0 V (12 V)
Max. Charge Current	10 A (12 V)
Max. Discharge Current	10 A (12 V)
Max. Charge Voltage	14.6 V (12 V)
Max. Discharge Voltage	12.0 V (12 V)

Capacity: 40 kWh (12 V)

Energy Storage System (ESS) is a...
 Energy Storage System (ESS) is a...
 Energy Storage System (ESS) is a...
 Energy Storage System (ESS) is a...

SAJ logo and CE, TÜV, and other certification marks.

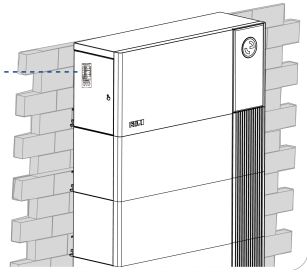

1.5. Wall mounting

Note: For wall mounting, a maximum of 2 batteries is supported.

1 Remove the bumper feet.

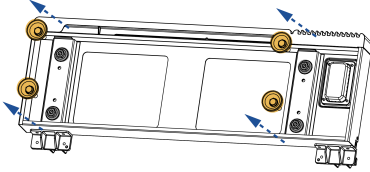

2

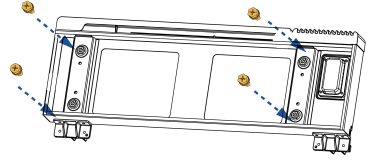

M6*16 6 N·m



3

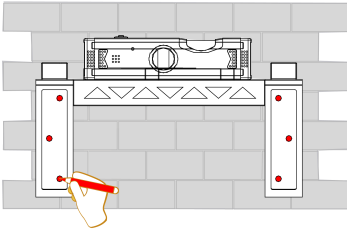

4

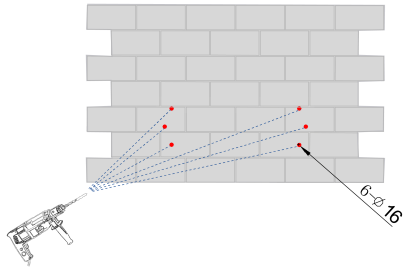

5

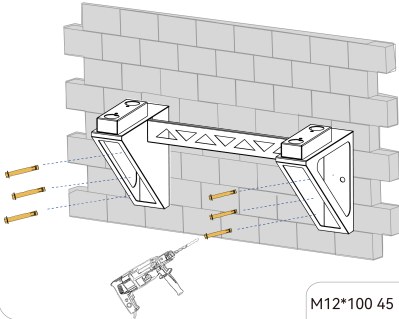

M12*100 45 N·m

6

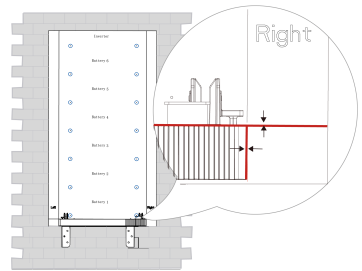

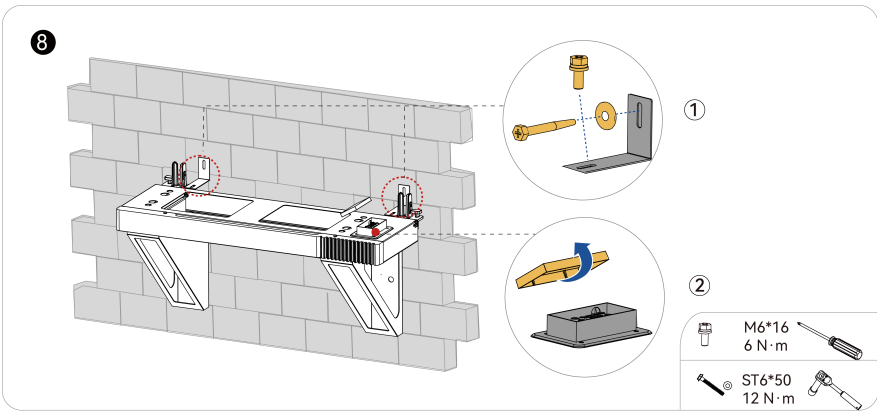
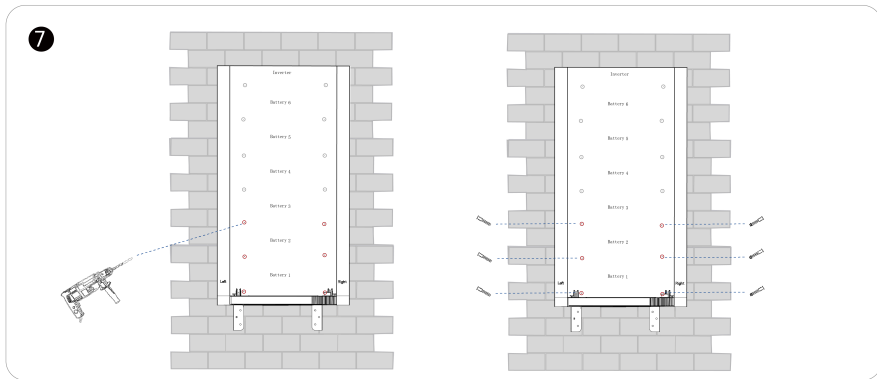

9 Install the batteries and inverter by taking the same steps as the ground mounting.

10

X represents the nominal energy of the battery system in kWh

X =	<input type="checkbox"/> 6	<input type="checkbox"/> 7	<input type="checkbox"/> 9	<input type="checkbox"/> 12	<input type="checkbox"/> 14	<input type="checkbox"/> 15	<input type="checkbox"/> 16
	<input type="checkbox"/> 18	<input type="checkbox"/> 21	<input type="checkbox"/> 24	<input type="checkbox"/> 25	<input type="checkbox"/> 27	<input type="checkbox"/> 28	<input type="checkbox"/> 30
	<input type="checkbox"/> 35	<input type="checkbox"/> 36	<input checked="" type="checkbox"/> 40	<input type="checkbox"/> 42	<input type="checkbox"/> 45	<input type="checkbox"/> 50	<input type="checkbox"/> 54

Example

2. Electrical connection

2.1. Electrical connection diagram

2.1.1. Inverter ports and switches

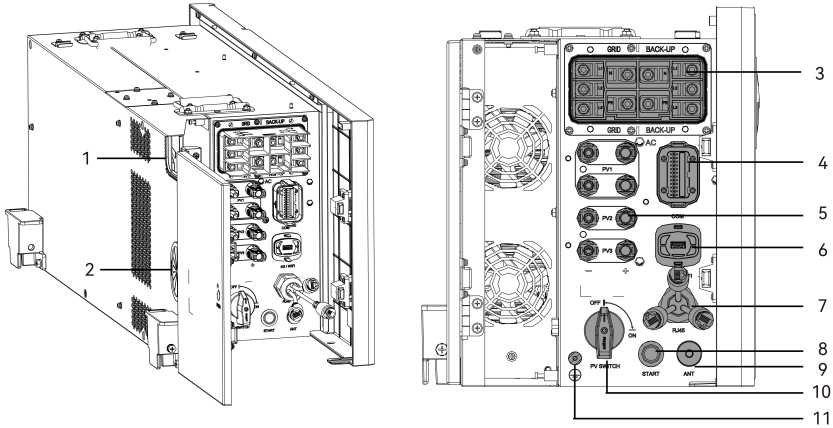

Callout	Silkscreen	Description
1	/	The cable entry hole 1 for routing AC power cables.
2	/	The cable entry hole 2 for routing the following cables: <ul style="list-style-type: none"> • The grounding cable • The DC power cables • The communication cables
3	AC <ul style="list-style-type: none"> • GRID • BACK-UP 	The connection ports for AC power cables. <ul style="list-style-type: none"> • GRID: for connecting to the public grid. • BACK-UP: for connecting to the home backup load.
4	COM	The connection port for communication cables from external devices like DI/DO devices.
5	PV1, PV2, PV3	The negative and positive PV input connection ports.
6	4G/WIFI	The connection port of the eSolar AI03 Pro and 4G Pro communication modules.
7	RJ45	The RJ45 connection ports for LAN1, LAN2, and DRMS connections. LAN1 and LAN2 are reserved for future use.

Callout	Silkscreen	Description
8	START	For starting up the energy storage system.
9	ANT	The LoRa antenna connection port.
10	DC SWITCH	The DC switch that controls the connection to the PV array.
11		The grounding cable connection port.

Table 2.1. Inverter electrical ports



Number	Silkscreen	Description
1-6	/	Reserved for future use.
7	DO1+	Output connection for dry contact device 1.
8	DO1-	Output connection for dry contact device 1.
9	DO2+	Output connection for dry contact device 2.
10	DO2-	Output connection for dry contact device 2.
11	PC 485A	Reserved RS485 connection ports.
12	PC 485B	The RS485 communication can be adjusted with the provided 120 Ω resistor controlled by SW2 DIP switch.
13	Meter 485A	For RS485 connections with the meter.
14	Meter 485B	The RS485 communication can be adjusted with the provided 120 Ω resistor controlled by SW3 DIP switch.
15	D11+	Input connection for dry contact device 1.
16	D11-	Input connection for dry contact device 1.
17	D12+	Input connection for dry contact device 2.
18	D12-	Input connection for dry contact device 2.

Number	Silkscreen	Description
19	12V	Port for providing 12V DC power supply to the external device.
20	GND	Port for grounding connection.

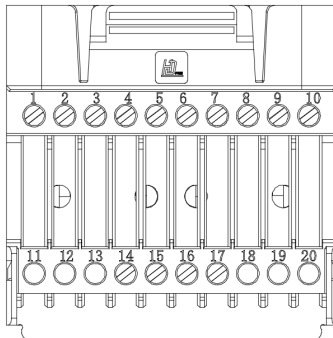
Table 2.2. 20-pin definition

2.1.2. Australia and New Zealand

This section shows the system connection diagrams applicable to Australia and New Zealand.

- To comply with AS/NZS3000, the neutral (N) cables of the grid and backup-load sides (where applicable) must be connected together.
- Do not connect the PE terminal of the **BACKUP** port.
- The E-BAR and the N-BAR must be connected as illustrated.

Whole home backup solution

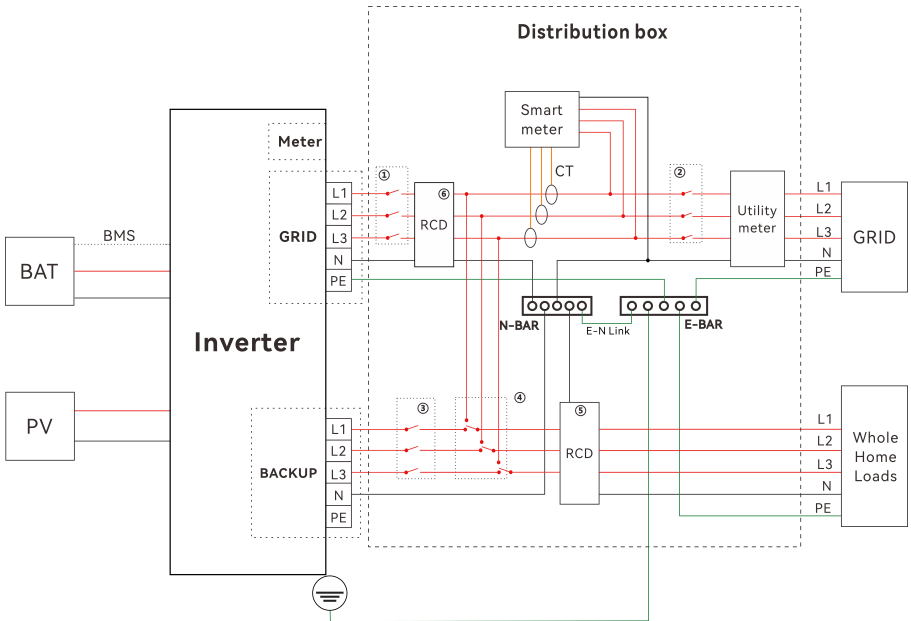

Product model	① AC breaker (grid)	③ AC breaker (backup loads)	② AC breaker (utility meter)	④ Manual transfer switch	⑤⑥ RCD (on-grid/ backup loads) ¹
EK90 HS5-8K-T3-X	63A/400 V	63A/400 V	Main breaker	63A/230 V	30 mA
EK90 HS5-10K-T3-X	63A/400 V	63A/400 V	Main breaker	63A/230 V	30 mA
EK90 HS5-12K-T3-X (-IE)	63A/400 V	63A/400 V	Main breaker	63A/230 V	30 mA
EK90 HS5-15K-T3-X	63A/400 V	63A/400 V	Main breaker	63A/230 V	30 mA
EK90 HS5-20K-T3-X	63A/400 V	63A/400 V	Main breaker	63A/230 V	30 mA

Table 2.3. Recommended AC breaker and RCD specifications

1. The on-grid RCD is optional since the inverter is integrated with a residential current monitoring unit (RCMU). However, if the external RCD must be installed according to the local regulations, install a type A RCD of action current 30 mA or higher.

Note: The values in the above table are recommendations only and can be set to other values based on the actual conditions.

Partial backup solution

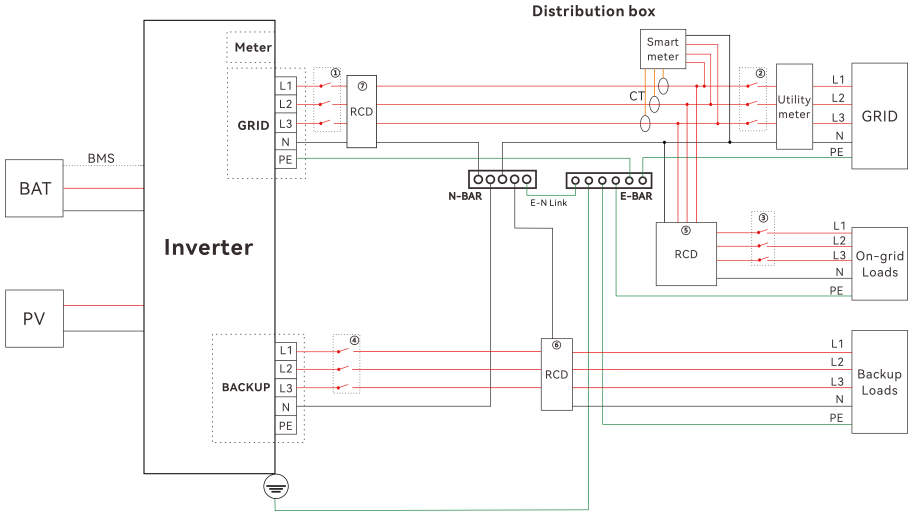

Product model	① AC breaker (grid)	④ AC breaker (backup loads)	② AC breaker (utility meter)	③ AC breaker (on-grid loads)	⑤⑥ RCD (on-grid/backup loads) ¹
EK90 HS5-8K-T3-X	32 A/400 V	Depend on loads	Main breaker	Depend on loads	30 mA
EK90 HS5-10K-T3-X	40 A/400 V	Depend on loads	Main breaker	Depend on loads	30 mA
EK90 HS5-12K-T3-X (-IE)	50 A/400 V	Depend on loads	Main breaker	Depend on loads	30 mA
EK90 HS5-15K-T3-X	63 A/400 V	Depend on loads	Main breaker	Depend on loads	30 mA

Product model	① AC breaker (grid)	④ AC breaker (backup loads)	② AC breaker (utility meter)	③ AC breaker (on-grid loads)	⑤⑥ RCD (on-grid/backup loads) ¹
EK90 HS5-20K- T3-X	63 A/400 V	Depend on loads	Main breaker	Depend on loads	30 mA

Table 2.4. Recommended AC breaker and RCD specifications

1. The on-grid RCD is optional since the inverter is integrated with a residential current monitoring unit (RCMU). However, if the external RCD must be installed according to the local regulations, install a type A RCD of action current 30 mA or higher.

Note: The values in the above table are recommendations only and can be set to other values based on the actual conditions.

2.2. Prepare the cables

Cable type	Recommended cross-sectional area range (mm ²)
Grounding cable	6

Table 2.5. Grounding cable specification

Solution	Cable type	Cross-sectional area range (mm ²)		Recommended conductor material
		Range	Recommended	
Whole home backup	One five-wire cable	10-16	16	Copper
	Five separated cables	/	16	Copper
Partial backup	One five-wire cable	6-8	8	Copper

Solution	Cable type	Cross-sectional area range (mm ²)		Recommended conductor material
		Range	Recommended	
	Five separated cables	/	8	Copper

Table 2.6. AC grid and backup cable specification

Cross-sectional area range (mm ²)		Recommended conductor material
Range	Recommended value	
5.0-6.0	6.0	Outdoor copper wire cable, complying with 600 V DC

Table 2.7. PV cable specification

Terminals	Cable diameter(mm ²)
1-10	0.5-0.75
11-20	0.2-0.5

Table 2.8. Communication cable specification

2.3. Connect the grounding cable

1

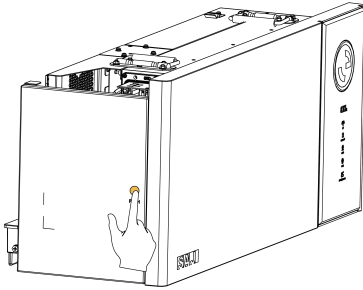

2

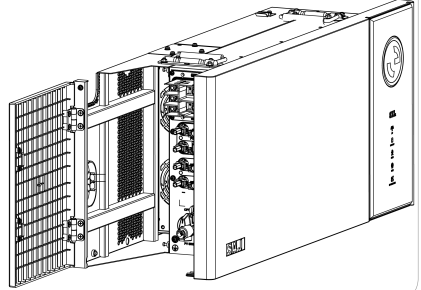

3

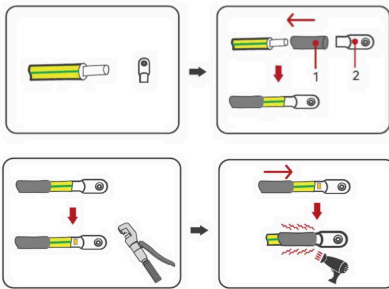

4

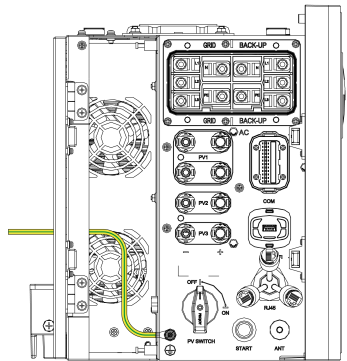







M4X10: 1-1.2 N·m

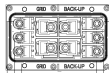

2.4. Connect the AC power cables

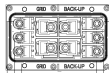
Note:

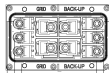
- Secure the corrugated pipe on the wall after finishing all wiring connections.
- When fixing the corrugated pipe at the upper left of the machine on the wall, leave an extra cable length of 300 to 400 mm. If it is fixed in other directions, reserve a longer length as needed.

 WARNING	<p>Do not connect the grid cables to the BACK-UP terminal.</p> <p>Do not connect the backup load to the GRID terminal.</p>						
AC connections							
<table style="width: 100%; border-collapse: collapse;"> <tr> <td style="text-align: center; width: 50%;">GRID</td> <td style="text-align: center; width: 50%;">BACK-UP</td> </tr> <tr> <td colspan="2" style="text-align: center;">  </td> </tr> <tr> <td style="text-align: center;">  Backup load </td> <td style="text-align: center;">  Grid </td> </tr> </table>		GRID	BACK-UP			 Backup load	 Grid
GRID	BACK-UP						
							
 Backup load	 Grid						

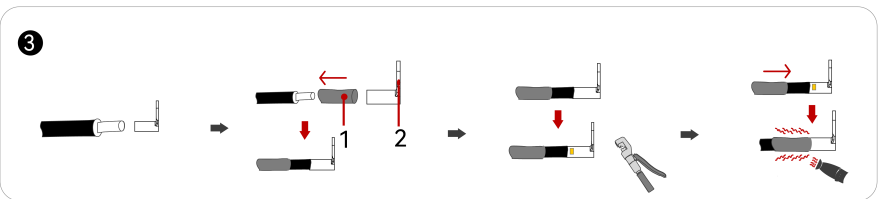
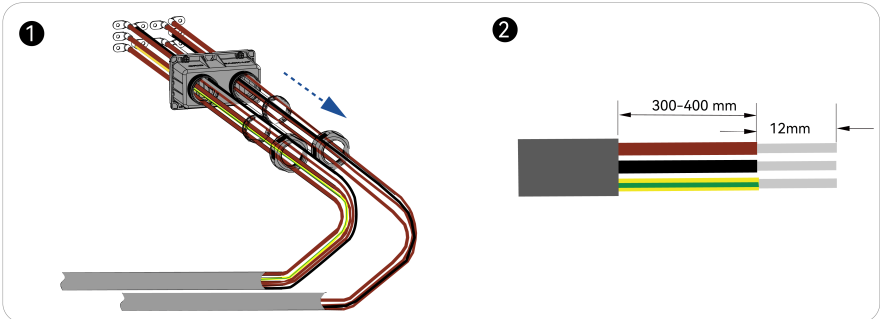

4

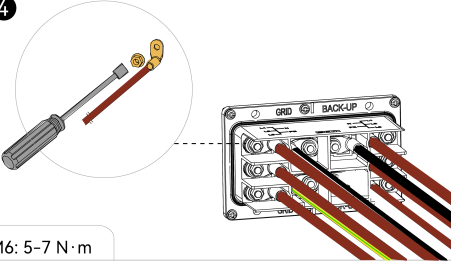

M6: 5-7 N·m

5

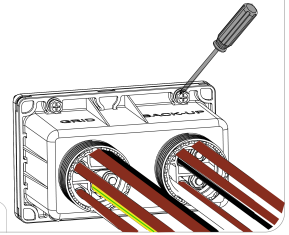

M5: 2-3 N·m

6

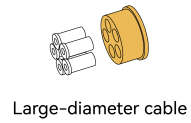
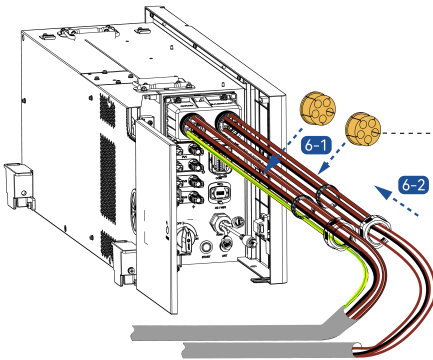

Large-diameter cable

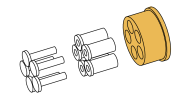

Small-diameter cable

7

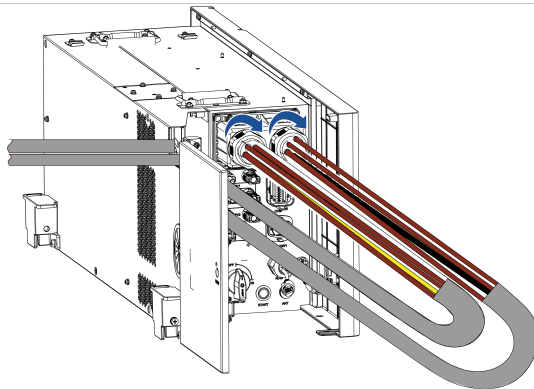

2.5. Connect the DC power cables

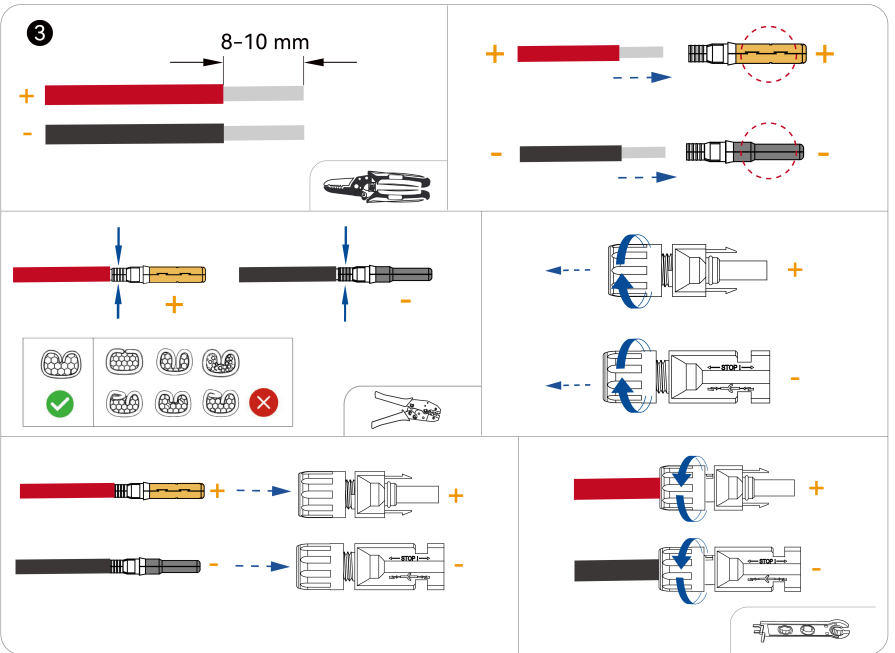
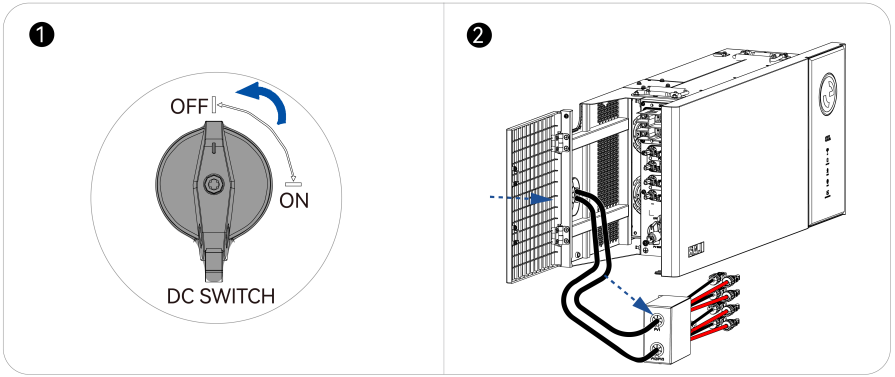

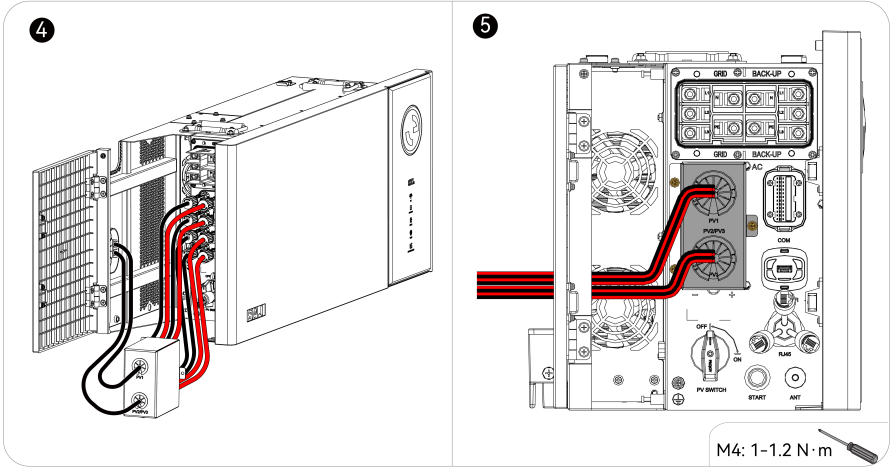

2.6. Connect the communication cables to COM port

① Disassemble the connector.

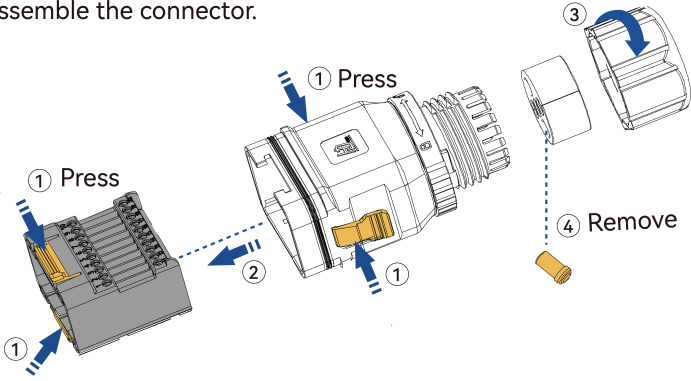

②

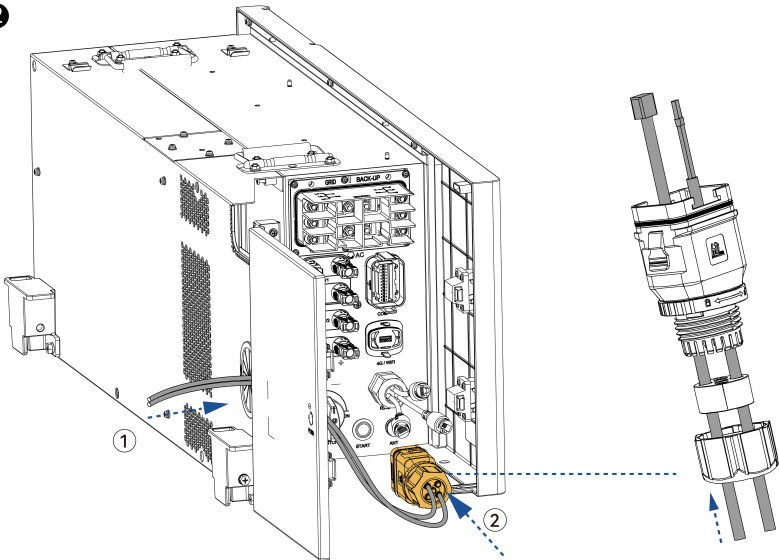

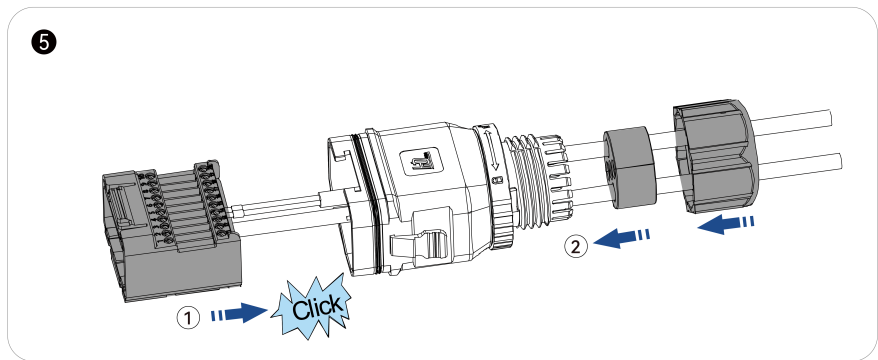
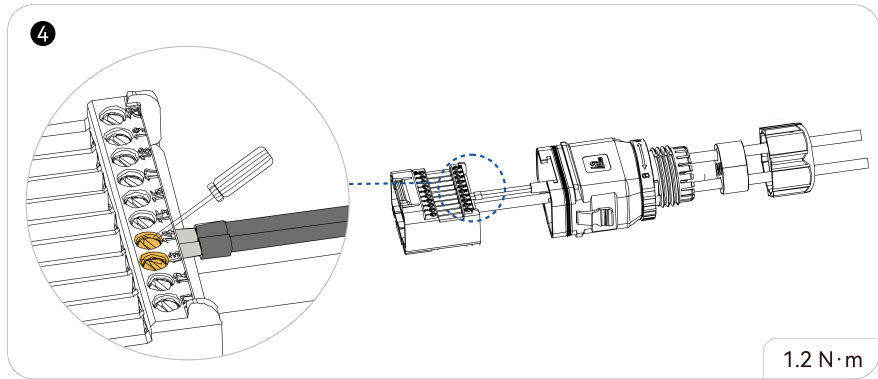
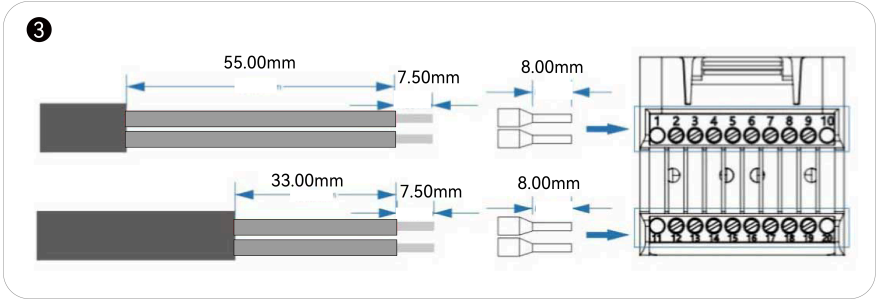

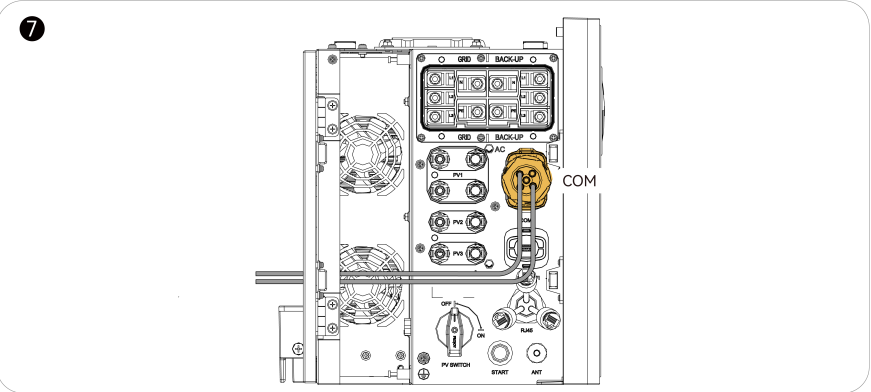
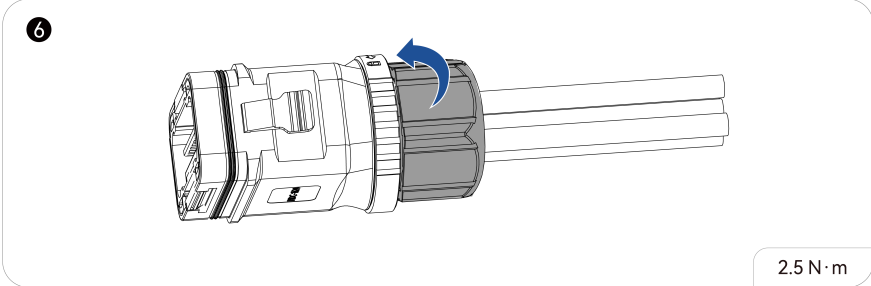

2.7. Connect the communication module

eSolar AIO3 Pro module (Ethernet)

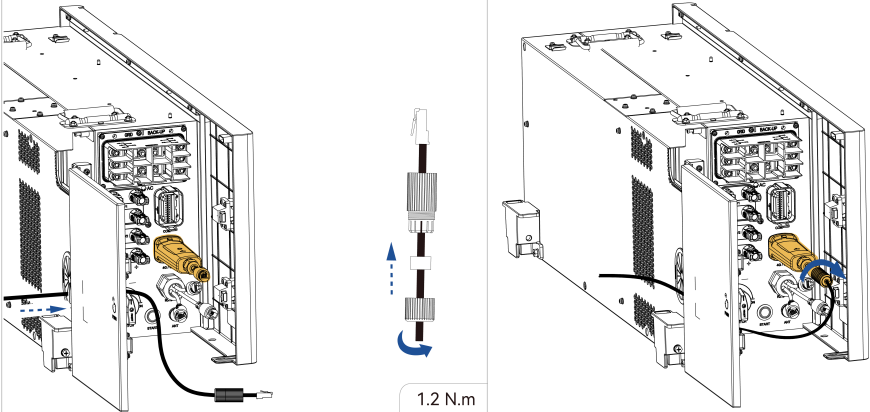

eSolar AIO3 Pro module (Wi-Fi)

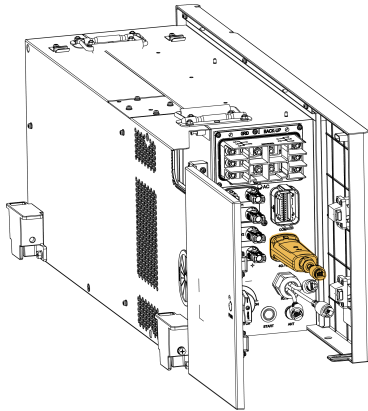

eSolar 4G Pro module

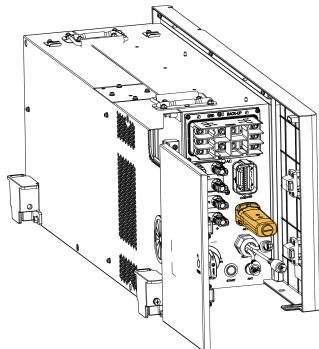
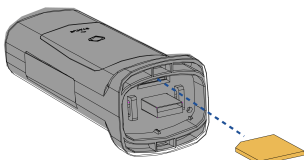

2.8. Connect the LAN and DRMS cables

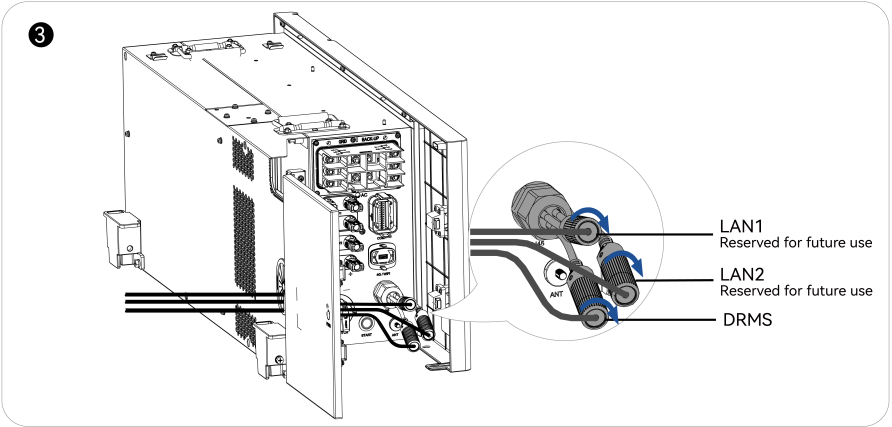
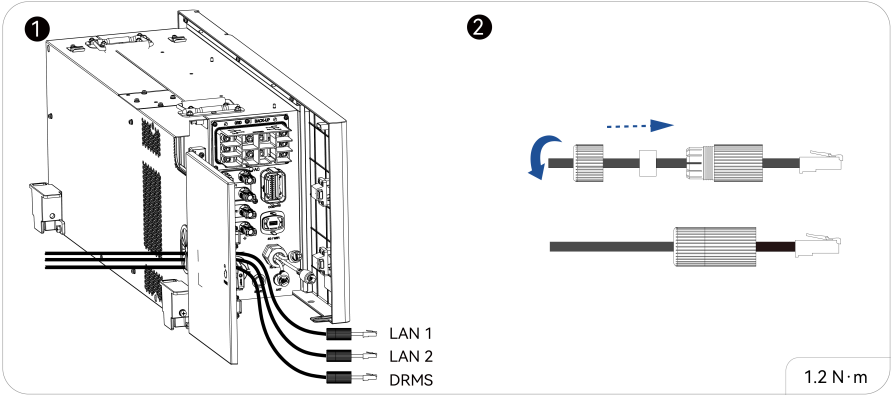

2.9. Connect the antenna

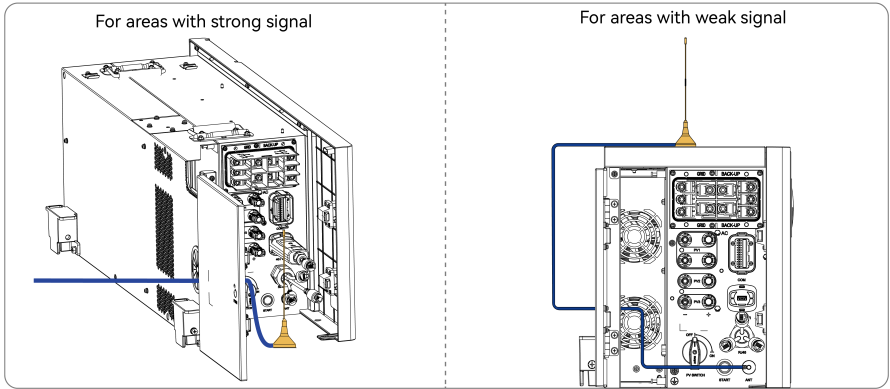

2.10. Install the inverter cover

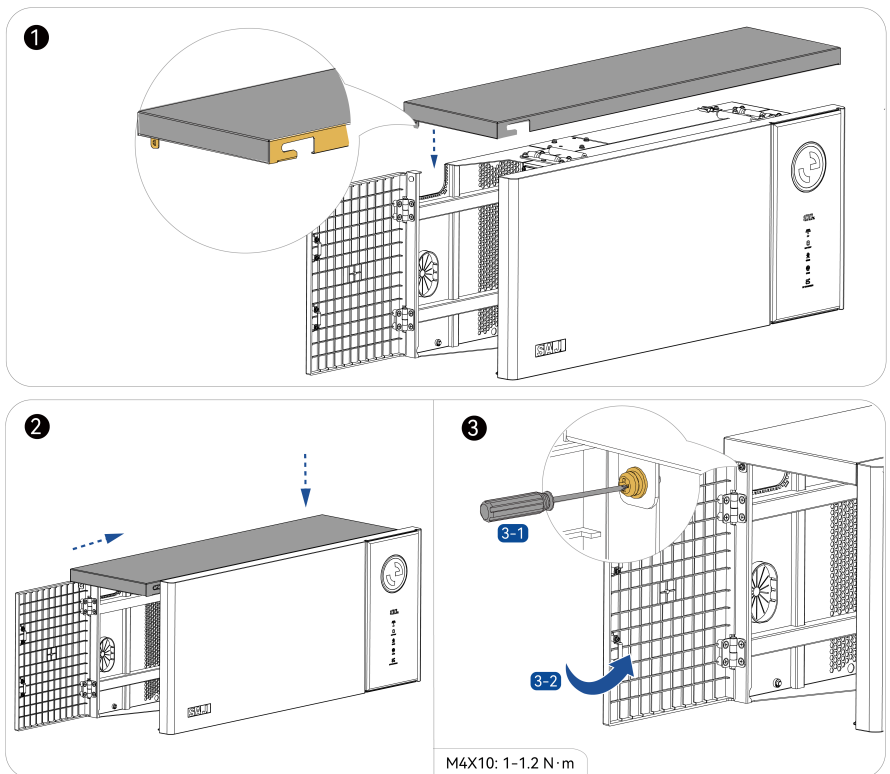

3. Start up the system

Before you begin

Verify that all the electrical connections are properly wired and secured before starting up the system.

1. Open the AC distribution box.
2. Turn on the following circuit breakers in sequence.
 - a. The backup loads
 - b. The grid
3. On the left side of the inverter, perform the following steps:
 - a. Turn on the DC switch to enable the connection to the PV arrays.
 - b. Press and hold the **START** button for five seconds until the LED indicator on the front panel is on.
 - c. Check the LED indicator status on the inverter panel to ensure that the inverter is running properly.

4. LED on the inverter



Figure 4.1. Inverter LED panel

Display	Color	Status	Description
	Green	Solid on	The inverter is working properly with grid connection.
		Breath, on 1.5s, off 1.5s	The inverter is in initialization or standby state.
		Breath, on 3s, off 3s	The inverter is working properly off-grid.
		Breath, on 0.5s, off 0.5s	The inverter is working off-grid with SOC lower than 20%.
	Red	Solid on	The inverter is faulty.
	Yellow	Breath, on 3.5s, off 3.5s	The inverter is upgrading.
Gray	Off	The inverter is powered off.	

Table 4.1. LED light

Display	Color	Status	Description
	White	<i>Integer</i> (example, 50)	Battery state of charge (SOC). For example, 50%.
		--	The battery communication is lost.



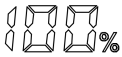

Display	Color	Status	Description
 PV	White	Solid on	The PV array is working.
		Off	The PV array is not connected.
	Red	Solid on	The PV array is faulty.
 BATTERY	White	Solid on	The battery is charging.
		Breath, on 1s, off 1s	The battery is discharging.
		Off	The battery is disconnected or inactive.
 GRID	White	Solid on	The inverter is working with grid connection.
		Breath, on 3s, off 3s	The inverter is working off-grid.
		Off	No grid is detected.
 COM	White	Solid on	In good communication with the meter, BMS, and cloud.
		Breath, on 1s, off 1s	Lost communication with the meter, BMS, or cloud.
	Red	Off	Lost communication with all the meter, the BMS, and cloud.

Table 4.2. LED indicators

5. Shut down the system

1. Open the AC distribution box.
2. Turn off the following circuit breakers:
 - a. The backup loads
 - b. The grid
3. On the left side of the inverter, perform the following steps:
 - a. Turn off the DC switch to disconnect from the PV arrays.
 - b. Press and hold the **START** button for five seconds, and then release the button and wait until the LED indicator on the front panel is off.
Once the system is shut down, there is no voltage output at the positive and negative terminals. Do not forcibly activate the system to output voltage by other means.



SJ | 守护者

GUANGZHOU SANJING ELECTRIC CO., LTD

Tel: (86) 20 66608588 **Fax:** (86) 20 66608589 **Web:** www.saj-electric.com

Add: No.9, Lizhishan Road, Science City, Guangzhou High-tech Zone, Guangdong, P.R.China